

GB

EXact2 HMI2-350-TOUCH Control System

Basic instructions VEX320-370/VEX310T-350T/
CX340-350

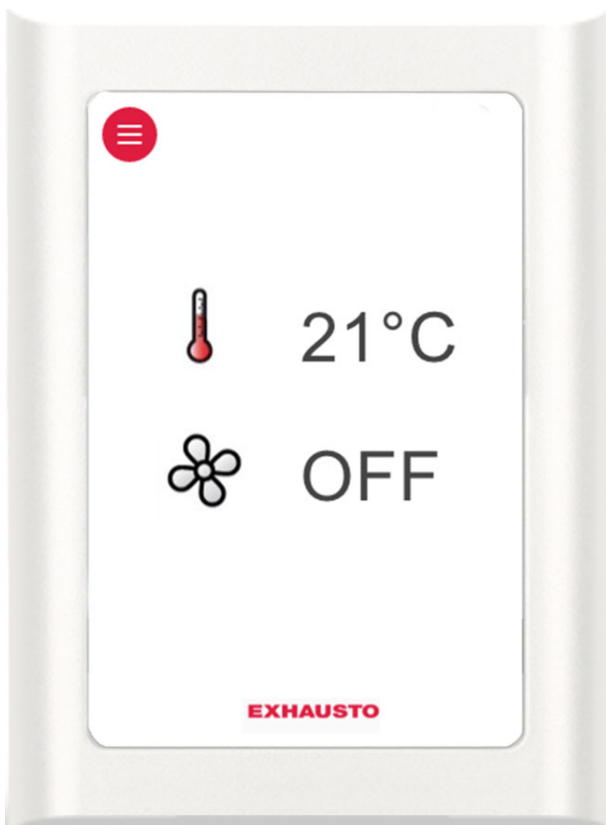
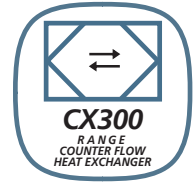
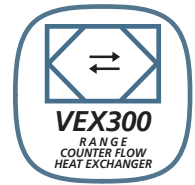

Original instructions

Symbols and software version	
Symbols used in these instructions	5
Software version	5
Software version	5
1. Menu structure	
1.1. Overview of menus and user levels	6
2. User mode	
2.1. Operation	7
2.1.1. Use of control icons in the menus.....	7
2.2. Overview of HMI icons	8
3. Technician and service levels	
3.1. Passwords technician and service levels	10
Menu 3.2 - Selecting language	11
Menu 3.2.1 - Setting date and time	11
Menu 3.2 - Reset settings	11
Menu 3.2 - Reload database	12
Menu 3.6 - Web server	12
Menu 3.7 - Backup/restore	13
3.2. IMPORTANT when servicing	14
3.2.1. Additional service HMI panel.....	15
4. Starting up the unit for operation	
4.1. Getting started	18
Start configuration.....	19
Menu 3.3 – Configuration.....	19
Menu 3.4 - Accessories.....	20
Menu 3.4 Connecting heating and cooling units	22
4.2. De-icing principles VEX320-330/CX340-350/VEX310T-350T	22
4.2.1. Bypass de-icing	22
4.2.2. Two de-icing methods	22
4.3. Temperature controlled frost protection -- choice of method VEX320/330/ VEX310T-350T	23
4.4. Pressure controlled frost protection -- choice of method VEX320-330/ CX340-350/VEX310T-350T	24
4.5. VEX340 de-icing methods	24
Method	24
4.6. VEX 350/360/370 - De-icing methods	25
Method	25
Selecting method for VEX350/360/370.....	26
Menu 3.5 BMS	27
Menu 3.5 - BMS.....	27
4.7. What is an indoor air quality level?	27
Menu 1 - Selecting operating mode	28
Menu 3.1.1 - Operating settings - Air regulation	28
Menu 3.1.1 - Operating settings Balance.....	31
Menu 3.1.1.5 Regulators	32
Menus 3.1.1.1.1 to 3.1.1.1.4 Setting the selected indoor air quality levels	32
Menu 3.1.1.1.x - Air set point	32
Menu 3.1.1.1.x - Temperature set point	32
Menu 3.1.1.1.x - Absolute/Relative temperature	33
Menu 3.1.1.1.x - Cooling relative start	33
Menu 3.1.1.1.x - Heating relative start	33
Menu 3.1.1.1.x - Cooling absolute start	34
Menu 3.1.1.1.x - Heating absolute start	34
Generally on temperature regulation	34
Menu 3.1.8 - Temperature limits.....	34
Menu 3.1.1.1.x - Supply air regulation, absolute	36
Menu 3.1.1.1.x - Room temperature regulation, absolute	37
Menu 3.1.1.1.x - Supply air regulation, relative	38
Menu 3.1.1.1.x - Room temperature regulation, relative	40
Menu 3.1.1 - Operation settings - Temperature regulation	41

	Compensation.....	42
	Menu 3.1.2 - Air compensation.....	42
	Menu 3.1.2.1 - CO2 compensation	43
	Menu 3.1.2.2 - Humidity compensation of airflow	44
	Menu 3.1.2.3 - Airflow reduction	44
	Menu 3.1.2.4 - Outdoor compensation of airflow	45
	Menu 3.1.3 - Temperature compensation.....	46
	Menu 3.1.3.1 - Outdoor air temperature compensation	46
	Menu 3.1.3.2 - Summertime compensation	47
	Menu 3.1.4 + Menu 8.1 - Filter (monitoring in case of pressure)	47
	Menu 3.1.5 - Night-time cooling	48
	Menu 3.1.6 - Cold recovery.....	50
	Menu 3.1.7 - Fan limits.....	50
	Menu 3.1.8 - Temperature limits for supply air and room.....	50
	Room temperature limits.....	51
	Menu 3.1.9 - MXHP settings.....	51
	Menu 3.1.10 - MCOCW settings.....	51
	Menu 5 - Time and weekly plan.....	52
	Menu 5.1 - Date and time.....	52
	Menu 5.2 - Weekly plan	52
	Menu 7 - Safety functions.....	53
	Menu 7.1 - Fire alarm.....	53
	Menu 7.2 - Frost protection of HCW	54
	Menu 7.3 - Frost protection heat exchanger	55
	Tice (VEX320-330).....	55
5. Operation		
	Menu 2 - Operating readings.....	57
	Menu 2.1 - Air temperatures	57
	Menu 2.1.1 - Set points for regulators	58
	Menu 2.2 - Airflows	58
	Menu 2.3 - Motor controller parameters (MC parameters)	58
	Menu 2.4 - Temperature regulating units	59
	Menu 2.5 - Pressure.....	60
	Menu 2.6 - Heating coil	60
	Menu 2.7 - CH cooling unit.....	60
	Menu 2.8 - CCW cold water coil	61
	Menu 2.9 - CU cooling unit.....	61
	Menu 2.10 - MXCU external cooling unit.....	61
	Menu 2.11 - External cooling/heating pump unit MXHP.....	61
	Menu 2.12 - Hour counters (VEX340-350-360-370/CX340-350/ VEX310T-350T).....	61
	Menu 2.13 - CO2/RH sensors (if mounted).....	62
	Menu 6 - Versions.....	62
	Menu 8 - Service.....	62
	Additional service HMI panel.....	63
	Menu 8.2 - VDI 6022.....	66
	Menu 8.3 - Forced start	66
	Menu 8.3.1 Fans.....	66
	Menu 8.3.2 Heating coil.....	66
	Menu 8.3.3 Cooling unit.....	67
	Menu 8.3.4 Dampers and relays.....	67
	Menu 8.4 - Calibrating MPT.....	67
6. Alarms		
	6.1. Alarms and info (Menu 4).....	69
	6.2. Reset alarms.....	69
	6.3. Alarm display and Current list – cause of error.....	70
	6.4. List of alarms.....	71
Appendix 1 - Simplified diagrams		
	Simplified diagrams.....	106
	Simplified diagrams for unit with chiller	106

VEX320L	106
VEX320R	107
VEX330CL.....	108
VEX330CR.....	109
VEX330HL.....	109
VEX330HR.....	110
VEX340L	110
VEX340R	111
VEX350L - VEX360L	111
VEX350R- VEX360R	112
VEX370L HCWi.....	112
VEX370R HCWi.....	112
VEX370L	113
VEX370R	113
CX340/350.....	114
VEX310TR-VEX350TR.....	115
VEX310TL-VEX350TL.....	116

Appendix 2 - Temperature resistance table

Temperature resistance table DC95.....	117
--	-----

Symbols and software version

Symbols used in these instructions

Prohibition symbol



Failure to observe instructions marked with a prohibition symbol may result in serious or fatal injury.

Danger symbol



Failure to observe instructions marked with a danger symbol may result in personal injury and/or damage to the unit.

Software version

Software version

This manual applies from the following version:

AHUC: 3.11.1.0

HMI: 4.1.0.0

1. Menu structure

1.1 Overview of menus and user levels

User menu:

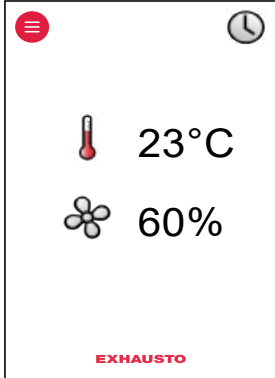
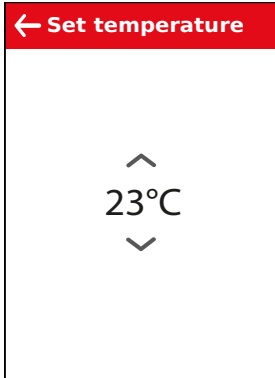
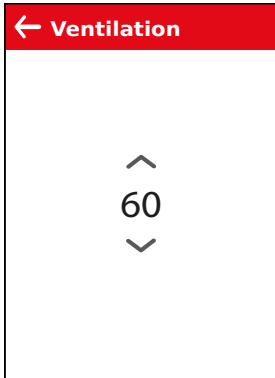
Technician and service menu:

Main menu

- Operating mode >
- Operating readings >
- Settings >
- Alarm and info >
- Time and weekly plan >
- Versions >
- Safety functions >
- Service >
- Save settings >

Select menu by using arrow up and arrow down keys.
 Activate by pressing on menu.

Press return arrow to switch between the user and technician menu, or to exit the menu.

1 Operating mode

Operation > Manual

2 Operating readings

Air temperature >

- Airflows >
- MC parameters >
- Temp. reg. units >
- Pressure >
- Heating coil >
- CH cooling unit >
- CCW
- CU cooling unit >
- MXCU
- MXHP
- Timers >
- CO2/RH sensorer >

3 Settings

Unit >

- General >
- Configuration >
- Accessories >
- BMS >
- Web server >
- Backup/restore >

4 Alarm and info

Alarm	Yes
Warning	No
Information	No
Reset alarms >	No
Current list >	
Alarm log list >	
Delete alarm log >	No

5 Time and weekly plan

Date and time >

Weekly plan >

6 Versions

PO Number > 1234567

- Hardware >
- Software >
- About EXact >

7 Safety functions

Fire alarm >

- Frost protection HCW >
- Frost protection HR >
- CH cooling unit >

8 Service

Filter >

- VDI 6022 >
- Forced start >
- Calibration of MPT >
- Light > Off

9 Save settings

Save settings > No

Last saved:

Date	xx.xx.xxxx
Time	xx:xx.xx





2. User mode

2.1 Operation

















2.1.1 Use of control icons in the menus









HMI - Human Machine Interface panel

Control icon	Used for...
	Menu icon
	Navigation arrows up and down as well as setting values.
	Approve icon for selection.
	Undo icon.
	Switch between daily user menu and technician/service menu. Exit a menu without making changes

2.2 Overview of HMI icons







Icon	Description
	Manual operation
	Timer overridden until next changeover in the timer schedule
	Timer, current indoor air quality level is comfort
	Timer, current indoor air quality level is economy
	Timer, current indoor air quality level is standby
	Timer, VEX/CX has stopped
	Timer, no changeover times defined in timer schedule
	BMS-controlled operation
	Externally-controlled operation
	Setpoint for temperature shown in °C
	Setpoint for ventilation shown as percentage: 0% = no ventilation OFF = Unit is switched off - timer operation cannot start up unit
	BMS or Web server-controlled system overrides the OFF function. This means the system may start up even if set to OFF
	The unit is running de-icing (De-ice)
	Unit alarm. Contact the service technician who can help reset the alarm. Icon is also shown in the technician menu
	Warning. Contact the service technician who can help reset the warning. Icon is also shown in the technician menu
	Service display connected

Icon	Description
	External start/stop disconnected. See Electrical Installation Guide for further information
	Summertime
	Wintertime
	No communication on the external BUS, or communication between the VEX/CX and HMI is disconnected
	Fire alarm. Closed circuit open and the pre-set fire alarm function activated
	Startup: Web server accessing database. The icon is displayed until the HMI panel is ready for use.

3. Technician and service levels

3.1 Passwords technician and service levels

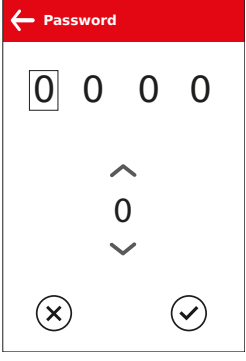
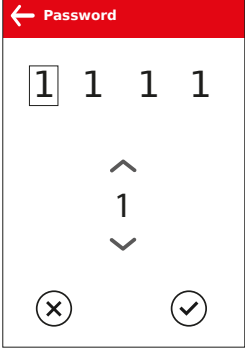

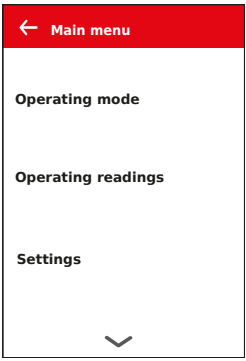
Step	Action	The display shows
1	<p>If the display is in stand-by: Press the display to activate full light.</p> <p>Press the  menu icon</p>	
2	<p>Press the number in the code row to activate and select the number via the up/down arrows</p> <p></p> <p>When the whole number code has been selected, approve with </p> <ul style="list-style-type: none"> The code for technician mode is 1111 (some menus are hidden or read-only). EXHAUSTO recommends this mode be used for normal service tasks The code for the specialist level is 3142 (full access to all menus). <p> NB: incorrect settings (wrong values) may have a negative impact on unit operation in some menus</p>	 
3	<p>Press  the up/down arrow keys to find and select the desired function in the main menu.</p>	
<p>NB:</p> <ul style="list-style-type: none"> Automatically logs out and returns to the user menu if no buttons are pressed in a five-minute period 		

Menu 3.2 - Selecting language

The HMI is factory set to English – another language can be selected by:

Step	Action
	<div style="display: flex; justify-content: space-around;"> <div style="border: 1px solid black; padding: 5px; width: 30%;"> <p style="background-color: red; color: white; margin: 0;">3 Settings</p> <p>Unit ></p> <p style="background-color: black; color: white; margin: 0;">General ></p> <p>Configuration ></p> <p>Accessories ></p> <p>BMS ></p> <p>Web server ></p> <p>Backup/restore ></p> </div> <div style="border: 1px solid black; padding: 5px; width: 30%;"> <p style="background-color: red; color: white; margin: 0;">3.2 General</p> <p>Date and time ></p> <p style="background-color: black; color: white; margin: 0;">Language > English</p> <p>Reset settings ></p> <p>Reload database ></p> </div> <div style="border: 1px solid black; padding: 5px; width: 30%;"> <p style="background-color: red; color: white; margin: 0;">Main menu</p> <p style="background-color: black; color: white; margin: 0;">Operating mode ></p> <p>Operating readings ></p> <p>Settings ></p> <p>Alarm and info ></p> <p>Time and weekly plan ></p> <p>Versions ></p> <p>Safety functions ></p> <p>Service ></p> <p>Save settings ></p> </div> </div>
1	Select "Settings"
2	Select "General"
3	Select the required language in line 2 "Language"
4	Return to the main menu and select yes in "Save settings"

Menu 3.2.1 - Setting date and time

Step	Action
	<div style="display: flex; justify-content: space-around;"> <div style="border: 1px solid black; padding: 5px; width: 30%;"> <p style="background-color: red; color: white; margin: 0;">3 Settings</p> <p>Unit ></p> <p style="background-color: black; color: white; margin: 0;">General ></p> <p>Configuration ></p> <p>Accessories ></p> <p>BMS ></p> <p>Web server ></p> <p>Backup/restore ></p> </div> <div style="border: 1px solid black; padding: 5px; width: 30%;"> <p style="background-color: red; color: white; margin: 0;">3.2 General</p> <p>Date and time ></p> <p style="background-color: black; color: white; margin: 0;">Language > English</p> <p>Reset settings ></p> <p>Reload database ></p> </div> <div style="border: 1px solid black; padding: 5px; width: 30%;"> <p style="background-color: red; color: white; margin: 0;">3.2.1 Date and time</p> <p>Date > 22-02-2009</p> <p>Day > Wednesday</p> <p>Time > 13:11</p> </div> </div>
1	Select "Settings"
2	Select "General"
3	Select "Date and time" to set these parameters in Menu 3.2.1
4	Return to the main menu and select yes in "Save settings"

Menu 3.2 - Reset settings

Selecting "Reset settings" resets the user settings. See the menu guide for details of which menus are affected.

NB:



This cannot be undone and the VEX/CX restarts.

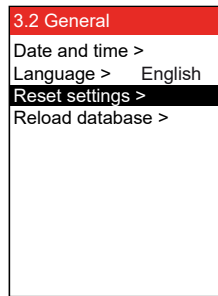

Menu 3.2 - Reload database

Selecting "Reset settings" resets the user settings. See the menu guide for details of which menus are affected.

Database reloads

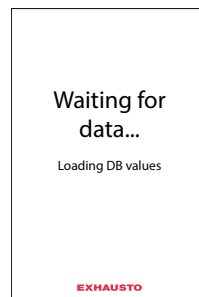

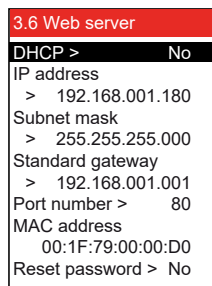

Menu 3.6 - Web server

Contact the network administrator for information on the correct IP address, etc. If the admin password is lost, it can be reset to the factory setting. But note that this cannot be reversed. See EXact web server instructions.

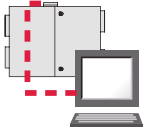

Menu 3.7 - Backup/restore

It is recommended that a backup copy of the VEX/CX settings is made and saved in a secure location. See the individual backup guidelines in the diagram:

	<p>Backup via the HMI panel</p> <ul style="list-style-type: none"> ● Insert the USB plug in one of the web server sockets ● Select menu 3.7 Backup/restore ● It can take up to 20 seconds before the connection to the USB is established; data will be lost if the process is interrupted. <p>The backup file can only be saved on a USB plug. Once the file has been saved it is not possible to change the file name or type. The file is named automatically as in this example: backup_20110918.file</p>
	<p>Backup via web server</p> <p>Follow the backup/restore instructions in the web server guide. The backup file may be saved on any medium (USB, PC etc.). A backup file saved via the web server may be renamed, but the file type cannot be changed.</p>
	<p>Note:</p> <p>If a backup file has been saved from the web server and then renamed, it cannot be retrieved (restored) via HMI until the name has been changed back to the standard form, see "Via HMI panel".</p> <p>If it is necessary to make backup files for several VEX/CX, it is recommended that each file is saved on a separate USB stick, or to create one folder per VEX /CX in which the backup files are saved.</p>

3.2 IMPORTANT when servicing

Do not open



the service doors before the supply voltage has been disconnected at the isolation switch. The isolation switch is located on the connection box, see illustration.

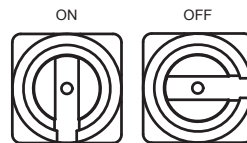

Weekly plan



It is important to set ventilation to OFF when the weekly plan is active:

Set ventilation to OFF	
<p>Note - If the HMI panel shows 0% (VEX/CX is inactive) and the unit is operating to a weekly plan when servicing begins, there is a risk that the program may be changed by timer operation and re-start the VEX unit.</p>	
<ul style="list-style-type: none"> • Log on to technician menu, using password 1111 • Change to manual operation via menu 1 • Change back to user menu • The icon for manual operation appears in the right-hand corner of the menu 	
<ul style="list-style-type: none"> • Press the ventilation icon • Set the ventilation to 0% using the arrows • Press approve 	
<ul style="list-style-type: none"> • OFF will now appear on the display next to the ventilation icon 	

BMS unit or Web server



If the VEX/CX is controlled via a BMS or Web server, these controls could override the OFF function and the VEX/CX may start up irregularly. To disconnect the BMS or WEB server connection, you must remove the plug from the EXact2 main board. Refer to the section on the terminal board in the Electrical Installation Guide.

3.2.1 Additional service HMI panel

If the HMI panel is located far from the VEX/CX, it is recommended that an auxiliary HMI panel be connected to the VEX/CX in the connection box.

**Example, Horizontal
VEX300**

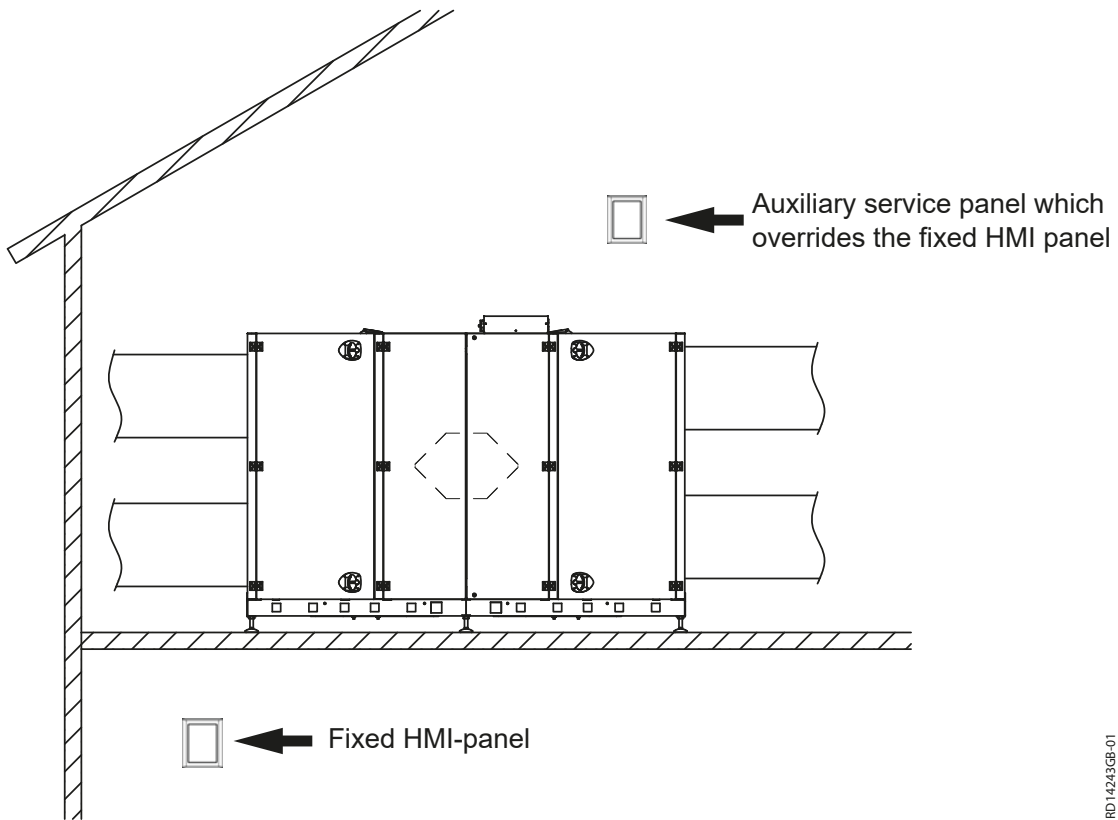

RD14243GB-01

Service panel connector - EXact2

Connector on EXact2 main board for auxiliary service panel

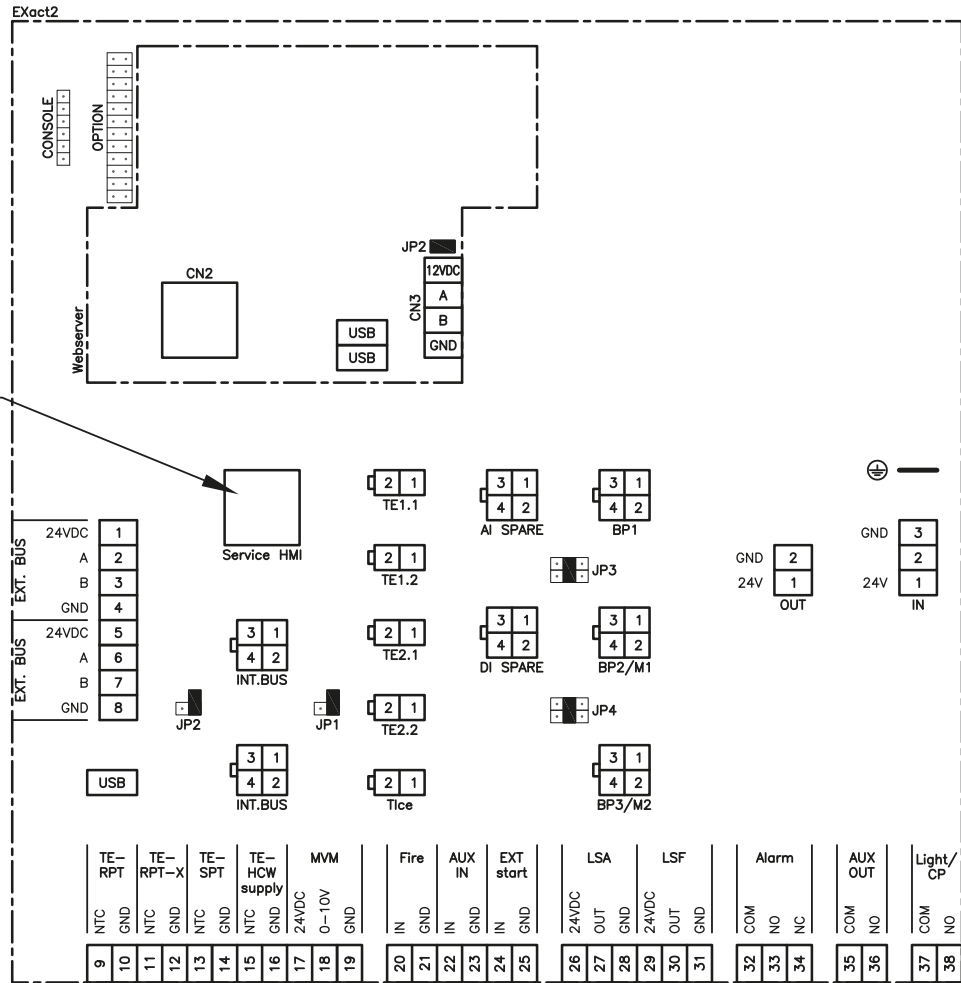

RD13093GB-01

Cable requirements

The service panel cable can be ordered from EXHAUSTO (product number: HMI2SERVICEC).

4. Starting up the unit for operation



The Modbus connectors must not be connected or removed while the units are powered up. Both Modbus units must be switched off before making changes, otherwise the units may be damaged.



During commissioning, it may be necessary to work with the control system boxes open. Components in these boxes must only be touched with electrically-insulated tools.



Before doing any work on motor controls or motor cables and terminal boxes, the power supply must be switched off for at least five minutes to allow the capacitors to discharge.

Before commissioning begins

- Check that the supply voltage is connected
- Set the HMI panel to specialist mode. See section 2.2

4.1 Getting started

From the main menu, follow the steps below to start the commissioning process.

Commissioning

Step	Action	Menu
1	Configure any external accessories or units (heating or cooling coils, chiller, sensors, etc.)	3.4
2	Select operating mode - Manual operation is the recommended setting during commissioning.	1
3	Set/activate operation settings	3.1
4	Program weekly plan	5.2
5	Set safety function settings	7
6	Select operating mode - change to timer operation if required	1

The various menu items are explained later in this section.

REMEMBER - Save settings

After changing menu settings it is always important to return to the main menu to save your settings by selecting "Save settings" in menu 9 (select yes). If power is disrupted before the settings are saved, the changes must be re-entered.

Main menu
Operating mode >
Operating readings >
Settings >
Alarm and info >
Time and weekly plan >
Versions >
Safety functions >
Service >
Save settings >

9 Save settings
Save settings > No
Last saved:
Date xx.xx.xxxx
Time xx:xx.xx

Start configuration

Step	Action
1	Check that the correct configuration for the VEX/CX has been selected at the factory via menu 3.3.
2	Check that all accessories have been configured in menu 3.4
3	If the CO ₂ sensor has been mounted, check in menu 3.1.2.1 "CO ₂ compensation", whether CO ₂ compensation has been activated.
4	If the humidity sensor (RH sensor) has been installed, check that humidity compensation has been activated in menu 3.1.2.2 "Humidity compensation".
5	Go to menu 4.5 "Current list", and check whether any units from the configuration menu are reporting errors. The alarm icon is visible on the user menu interface. 
6	If a unit is reporting an error but has been correctly configured, check the installation.

Menu 3.3 – Configuration

3.3 Configuration	
Type >	300
Size >	40
Orientation	H
Fan positioning	2
Direction	Left
Rotor type	Cond.
Cleaning zone	Mech.

Line in menu 3.3	Factory-set and should not be changed.
Type	X
Size	X
Orientation	X

Menu 3.4 - Accessories

3.4 Accessories	
Ice-detect. >	Pressure
De-icing method >	0
Heating coil >	MHCE
Cooling unit >	None
Power step HCE >	4
Filter detect. >	Timer
PIR >	PIR1
TS >	TS Room
CO2 >	MIOCO2
RH >	None
Dining solution >	No
AUX OUT setting >	1

Line in menu 3.4	Factory-set and should not be changed.	Remarks:
Ice detection method	x	Should only be changed when ice-detection sensors are retrofitted. Options: <ul style="list-style-type: none"> • Pressure • Tice
De-icing method		Select de-icing method (method no.) for de-icing of heat exchanger. See section on de-icing on following pages, where the VEXCX type and associated de-icing methods are described.
Heating coil		Options: <ul style="list-style-type: none"> • IHCW (set at the factory for the the EXact2 main board, if the VEX/CX was purchased with HCW) • MHCE (Electric heating coil) • MHCW (Water heating coil) • MCOCW (Cooling-heating coil) • None
Cooling unit		Options: <ul style="list-style-type: none"> • CH • CU (cooling unit from EX-HAUSTO) • CCW (cold water coil) • MXCU (external cooling unit) • MXHP (External cooling/heating pump units) • None
Power rating step HCE		This menu item is only active if MHCE is selected (Can only be active for VEX340-50-60/CX340-50).
Filter detection	x	Should only be changed when sensors for detecting filter soiling are retrofitted. Options: <ul style="list-style-type: none"> • Pressure • Hours

Line in menu 3.4	Factory-set and should not be changed.	Remarks:
PIR		Activating PIR sensor. Options: <ul style="list-style-type: none"> ● Both (Both MIOPIR and PIRB connected) ● PIR2 (PIRB connected) ● PIR1 (MIOPIR connected) ● None When the sensor(s) is/are activated by movement in the room, the VEX/CX will be overridden and set to comfort level. Comfort level will be maintained for the time set on the rear of the sensor (PIRB), after which the VEX/CX will return to the previous indoor climate level. Note: The time interval for MIOPIR is fixed at 10 minutes and cannot be changed).
TS		Activation of external temperature sensor and selection of type. Options: <ul style="list-style-type: none"> ● TS DUCT ● TS ROOM ● None
CO2		Activation of CO ₂ sensor Options: <ul style="list-style-type: none"> ● BMS ● CO2B (sensor connected to AI SPARE) ● MIOCO2 ● None
RH		Activation of RH sensor. Options: <ul style="list-style-type: none"> ● BMS ● RHB (sensor connected to AI SPARE) ● MIORH ● None
Dining solution		

Menu 3.4 Connecting heating and cooling units

Location A heating coil and a cooling unit can be connected to the VEX/CX. The example below (VEX340) shows the location of the coils in relation to the VEX/CX unit.

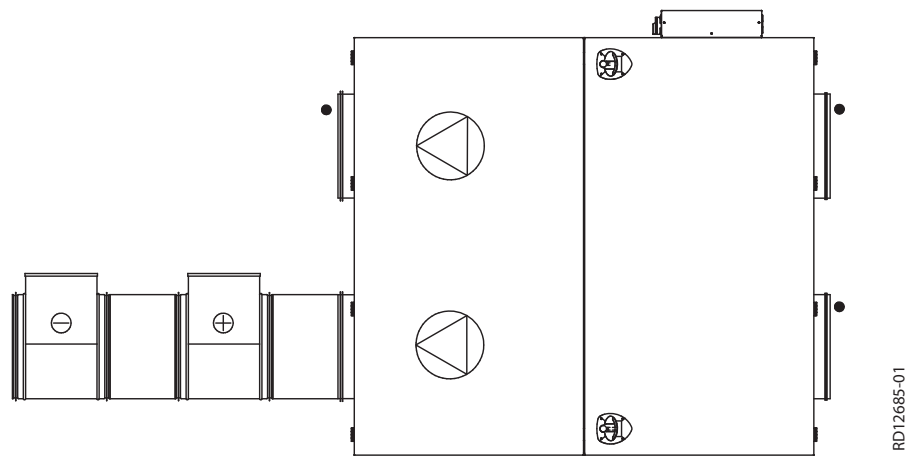

⊖ Cooling unit - ⊕ Heating coil.

4.2 De-icing principles VEX320-330/CX340-350/VEX310T-350T

4.2.1 Bypass de-icing

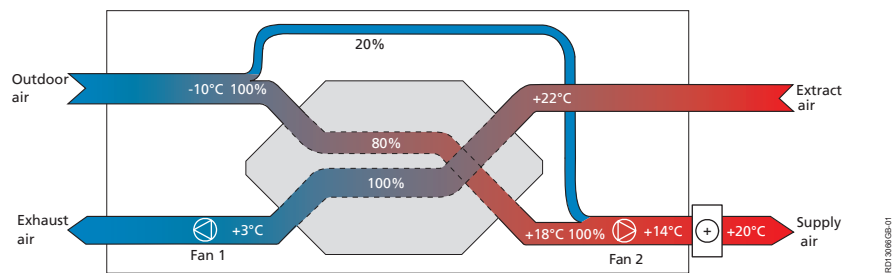

4.2.2 Two de-icing methods

Detection method	Method	De-icing starts when...
Temperature controlled (standard in control system)	Temperature sensor T_{ice} registers the temperature in the heat exchanger and starts the de-icing process when the indicated temperature is reached.	Temperature is below the set value e.g. $T_{ice} < 0^{\circ}C$. (Menu 7.3)
Pressure controlled (standard in the control system)	Pressure drop across the heat exchanger is constantly measured. If ice develops in the heat exchanger, the pressure drop will rise and at a pre-set value de-icing will start.	Pressure across the heat exchanger exceeds the set value, e.g. +45% (Menu 7.3)

4.3 Temperature controlled frost protection -- choice of method VEX320/330/ VEX310T-350T

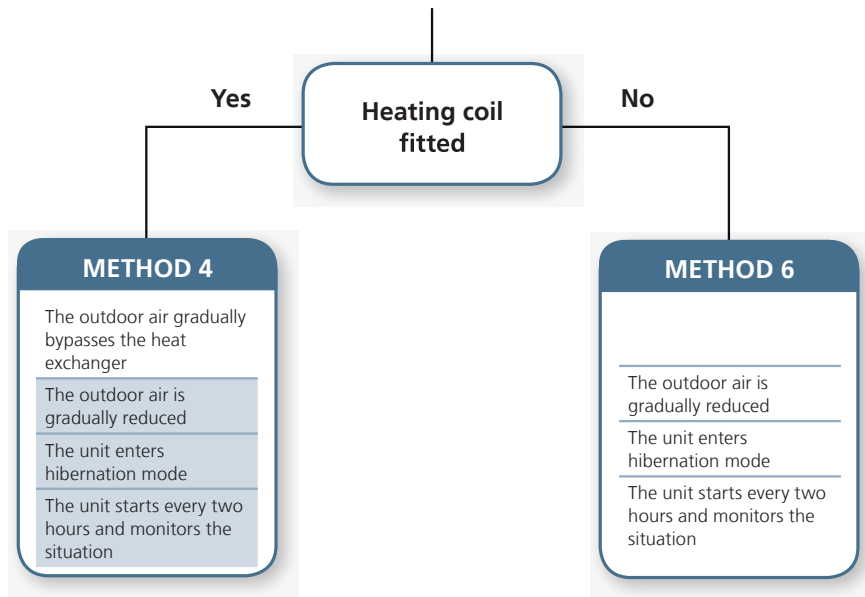

These steps only occur if the effect of the after heating coil is insufficient.

RD13144GB-01

Airflow control methods

See section "Menu 3.1.1 Operation settings air control" for a detailed definition of the different airflow control methods.

Start-up after hibernation

The unit restarts after two hours of hibernation. If

- the outdoor air temperature is two degrees Kelvin higher than when the unit entered hibernation mode, or
- if the temperature has risen above the level for activation of hibernation, normal de-icing operation continues.

If neither of these two conditions are met within five minutes, the unit will enter hibernation again.

4.4 Pressure controlled frost protection -- choice of method VEX320-330/ CX340-350/VEX310T-350T

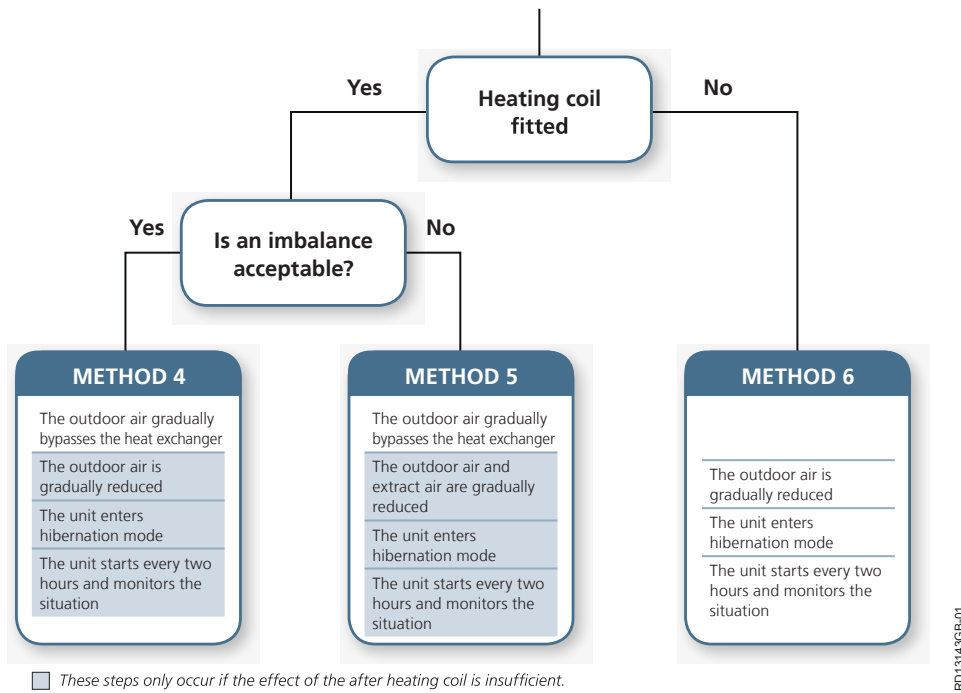

Balance/imbalance See definition of balanced/unbalanced operation in section "Operation settings balance".

Airflow control methods See section "Menu 3.1.1 Operation settings air control" for a detailed definition of the different airflow control methods.

Start-up after hibernation The unit restarts after two hours of hibernation. If

- the outdoor air temperature is two degrees Kelvin higher than when the unit entered hibernation mode, or
- if the pressure loss has fallen below the lower limit of activate-hibernation normal de-icing operation continues.

If neither of these two conditions are met within five minutes, the unit will enter hibernation again.

4.5 VEX340 de-icing methods

Method

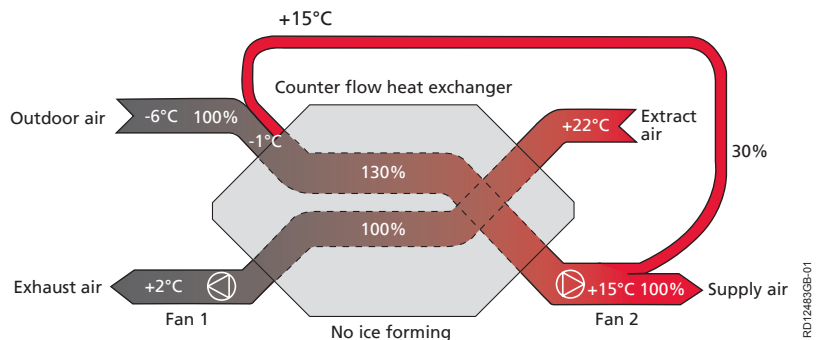

Selecting VEX340 method

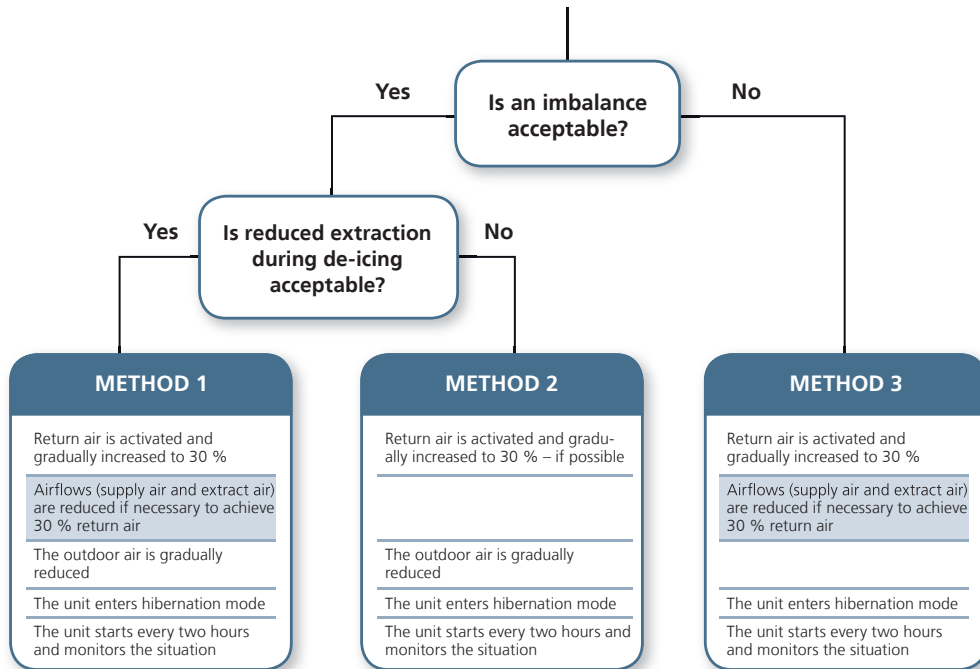

RD1267366-01

Balance/imbalance See definition of balanced/unbalanced operation in section "Operation settings balance".

Airflow control methods See section "Menu 3.1.1 Operation settings air control" for a detailed definition of the different airflow control methods.

Start-up after hibernation

The unit restarts after two hours of hibernation. If

- the outdoor air temperature is two degrees Kelvin higher than when the unit entered hibernation mode, or
- if the pressure loss has fallen below the lower limit of activate-hibernation normal de-icing operation continues.

If neither of these two conditions are met within five minutes, the unit will enter hibernation again.

4.6 VEX 350/360/370 - De-icing methods

Method

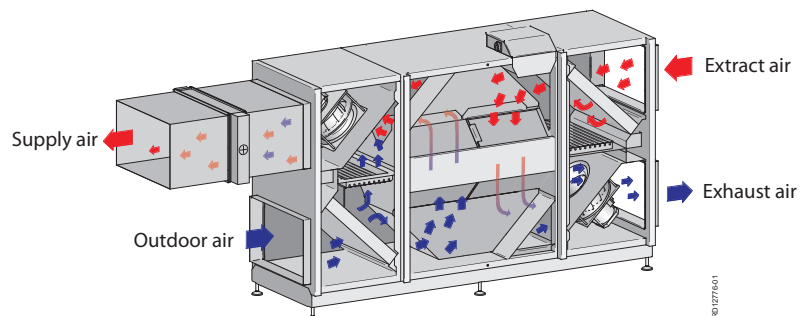

RD12776-01

Selecting method for VEX350/360/370

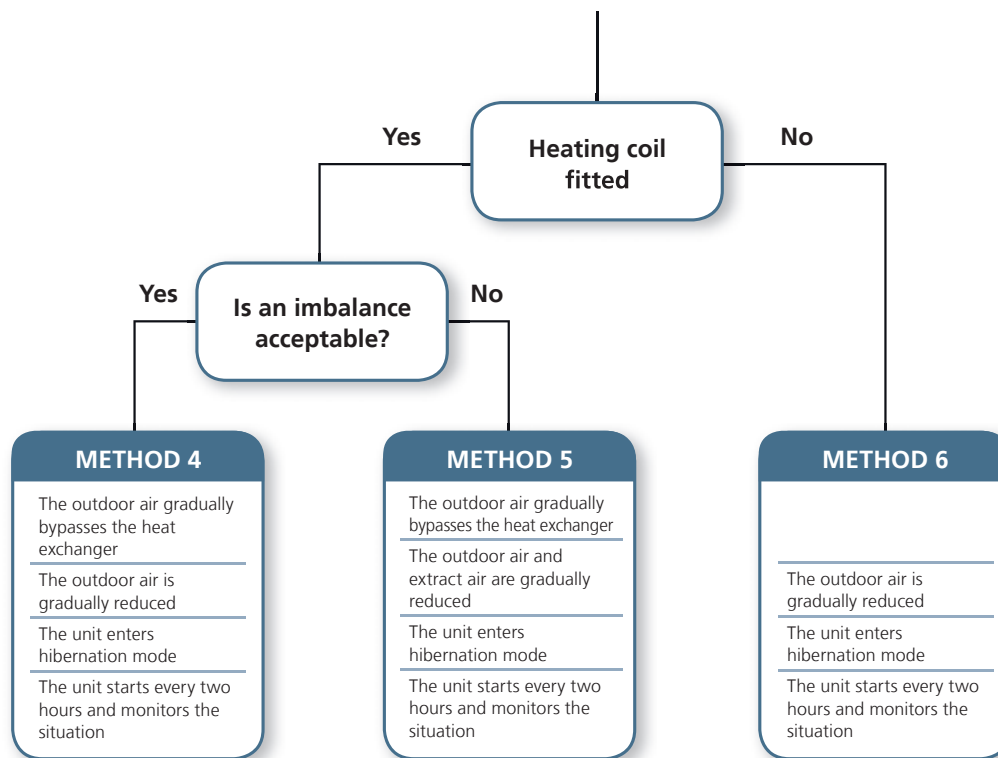

RD12862GB-01

Balance/imbalance See definition of balanced/unbalanced operation in section "Operation settings balance".

Airflow control methods See section "Menu 3.1.1 Operation settings air control" for a detailed definition of the different airflow control methods.

- NB:**
- If the temperature regulation method is selected for room temperature, the temperature regulation method changes temporarily to supply air temperature regulation when de-icing begins. The set point remains the same for the supply air temperature regulation
 - If the weekly plan changes while de-icing is running, it changes to the new set point that is set in the weekly plan

Start-up after hibernation The unit restarts after two hours of hibernation. If

- the outdoor air temperature is two degrees Kelvin higher than when the unit entered hibernation mode, or
- if the pressure loss has fallen below the lower limit of activate-hibernation normal de-icing operation continues. If neither of these two conditions are met within five minutes, the unit will enter hibernation again.

Menu 3.5 BMS

Menu 3.5 - BMS

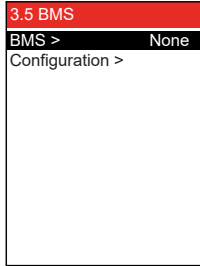

Line in Menu 3.5	Remarks:
BMS	Activating override control system BMS Options: <ul style="list-style-type: none"> • None • Modbus • MTCP • MLON • BACnet MS • BACnet IP
Configuration	Configuration of Modbus and BACnet MSTP.

BMS configuration See detailed description in the instructions for the protocols.

4.7 What is an indoor air quality level?

Example

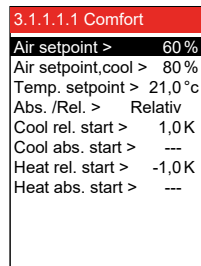

Indoor air quality level definition

The four indoor air quality levels - Comfort, Standby, Economy and Manual - are defined in menus 3.1.1.1.1 to 3.1.1.1.4. Parameters such as ventilation and temperature set points and control method for a given indoor air quality level are grouped in a menu, as shown in the example above. The table below shows suggested settings for each mode:

Indoor climate levels	Energy saving	People in the room	Air-replacement*	Deviation from desired room temperature*
(Ventilation stopped)	-	No	No ventilation	No control of room temperature
Economy Menu 3.1.1.1.3	Large	No	Low	Greatest temperature deviation permitted*)
Standby Menu 3.1.1.1.2	Small	No	Low	Least temperature deviation permitted*
Comfort Menu 3.1.1.1.1	None	Yes	High	Precise temperature
Manual Menu 3.1.1.1.4	Dependent on setting	Yes/No	Adjustable	Adjustable

* Air-replacement and temperature deviation set via the HMI panel.

The current indoor air quality level can be controlled in five ways:

- Via a weekly plan, based on the given operating requirements. Set via the HMI panel.
- Via an HMI panel in the room.
- Via sensor(s) positioned in the room or in the extract air duct (e.g. MIO-PIR, MIO-CO2, MIO-RH, MIO-TS)
- Via a PC connected to the built-in Web server
- via a high-level control system (e.g. a BMS unit)

NB: The Comfort indoor climate level is the overall indoor climate level. **The comfort level is also activated if a mounted PIR sensor gives a signal (the unit changes from an energy-saving indoor climate level/OFF).**

Menu 1 - Selecting operating mode

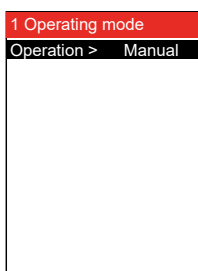

Select	If
Manual	The unit is intended to always operate at the same indoor air quality level (set in menu 3.1.1.1.4) and operation is controlled manually via the HMI panel or the Web server
Timer	The unit is controlled automatically via a fixed weekly plan

Note for commissioning

EXHAUSTO recommends that the operating mode be set to Manual during commissioning and changed to Timer operation when complete.

Note for manual

When the unit is operating in Manual indoor climate level, the values set for the temperature setpoint (Temp. setpoint) and Air setpoint are shown immediately in the user menu.

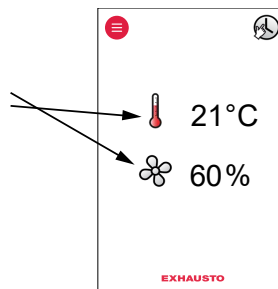
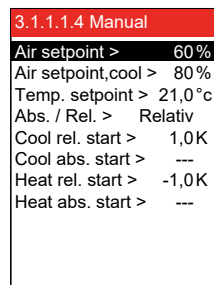

Menu 3.1.1 - Operating settings - Air regulation

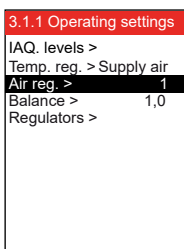

The control method can be selected from the methods shown in the table. Note that some of these methods require that an optional pressure sensor is fitted in one or more ducts (MPTDUCT).

NB: AFC (Air flow control) must be installed using method: 2, 3, 4, 5, 6. AFC is an accessory for VEX320/330.

Method	Method no. (1-8)	Description	The following parameters are set	Menu
Manual control	1	Constant speed Manual control of fan speed	<ul style="list-style-type: none"> Balance 	3.1.1 Operating settings IAQ. levels > Temp. req. > Supply air Air reg. > 1 Balance > 1,0 Regulators >
Airflow control	2	Constant airflow Maintains the airflow, compensating for changes in the ducting system, filter soiling, etc.	<ul style="list-style-type: none"> Extract airflow values for maximum and minimum ventilation (see capacity diagram in the VEX/CX instructions) Supply air balance relative to extract air 	3.1.1.4 Constant airflow Setp. maks. > 10000l/s Setp. min. > 0l/s Balance > 1,00
Constant pressure regulation of extract air	3	Constant pressure-regulated extract air with fixed supply air setting Requirements: <ul style="list-style-type: none"> MPT-DUCT negative pressure sensor in the extract air duct. Available as an accessory 	<ul style="list-style-type: none"> Extract airflow values for maximum and minimum ventilation Fixed setting for supply airflow 	3.1.1.4 Constant pressure Extract air: Setp. max. > 1000Pa Setp. min. > 0Pa Supply air: Setp. > 0l/s
	5	Constant pressure-regulated extract air with slave-controlled supply air Requirements: <ul style="list-style-type: none"> MPT-DUCT negative pressure sensor in the extract air duct. Available as an accessory 	<ul style="list-style-type: none"> Extract airflow values for maximum and minimum ventilation Supply air balance relative to extract air 	3.1.1.4 Constant pressure Extract air: Setp. max. > 1000Pa Setp. min. > 0Pa Supply air: Balance > 1.00

Method	Method no. (1-8)	Description	The following parameters are set	Menu
Constant pressure regulation of supply air	4	Constant pressure-regulated supply air with fixed extract air setting Requirements: <ul style="list-style-type: none"> MPT-DUCT overpressure sensor in the supply air duct. Available as an accessory 	<ul style="list-style-type: none"> Supply airflow values for maximum and minimum ventilation Fixed setting for extract airflow 	3.1.1.4 Constant pressure Supply air: Setp. max. > 1000Pa Setp. min. > 0Pa Extract air: Setp. > 0/s
	6	Constant pressure regulated supply air with slave-controlled extract air Requirements: <ul style="list-style-type: none"> MPT-DUCT overpressure sensor in the supply air duct. Available as an accessory 	<ul style="list-style-type: none"> Supply airflow values for maximum and minimum ventilation Extract air balance relative to supply air 	3.1.1.4 Constant pressure Supply air: Setp. max. > 1000Pa Setp. min. > 0Pa Extract air: Balance > 1.00
Constant pressure regulation of both extract air and supply air	7	Constant pressure regulation of both extract air and supply air Requirements: <ul style="list-style-type: none"> MPT-DUCT negative pressure sensor in the extract air duct. Available as an accessory MPT-DUCT overpressure sensor in the supply air duct. Available as an accessory 	<ul style="list-style-type: none"> Extract airflow values for maximum and minimum ventilation Supply airflow values for maximum and minimum ventilation 	3.1.1.4 Constant pressure Extract air: Setp. max. > 1000Pa Setp. min. > 0Pa Supply air: Setp. max. > 1000Pa Setp. min. > 0Pa
External control of fan speeds	8	External control of both extract air and supply air Requirements: <ul style="list-style-type: none"> Two MIO modules to convert 0–10 V to Modbus 	<ul style="list-style-type: none"> FC max/FC min: Control signal range for external control (e.g. 2-10 V signal) Control signal to override external damper* in the event of, e.g. night-time cooling or fire *or other external accessory, which is controlled by external control	3.1.1.4 AUX Type > None BFO BMS

Menu 3.1.1 - Operating settings Balance

Definition

Balance is the required ratio between the supply and extract airflows. The balance can only be maintained within certain operating ranges, limited by factors such as:

- Duct characteristics
- Minimum fan rpm
- Minimum airflow required
- Maximum airflow required

Example of balance

The examples show an air handling unit with manual fan control and balances of 0.8 and 1.20, respectively

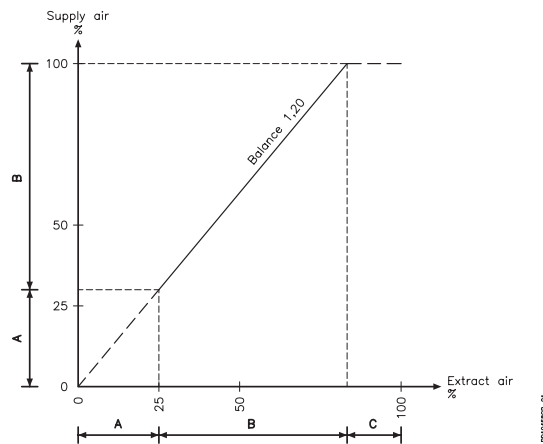
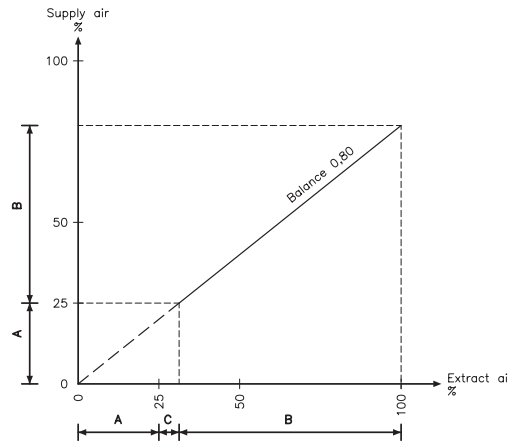

Range	The required airflow is
A	outside the unit's normal operating range
B	balanced
C	unbalanced

NB:

Less than 1 = less supply air - Greater than 1 = less extract air

Note that with methods 3, 4, 7 and 8

Balance is not active for air regulation methods 3, 4, 7 and 8.

Menu 3.1.1.5 Regulators

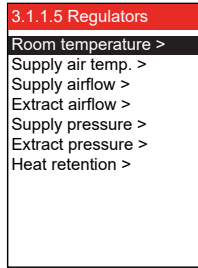

Kp and Ti settings should only be changed by persons trained in commissioning ventilation systems.

If the following is selected	Permitted operations
Technician mode (code 1111)	Read the settings for the various regulators
Specialist mode (code 3142)	Set Kp and Ti for the various regulators

Menus 3.1.1.1.1 to 3.1.1.1.4 Setting the selected indoor air quality levels

The menus for the four indoor air quality levels contain the same menu items:

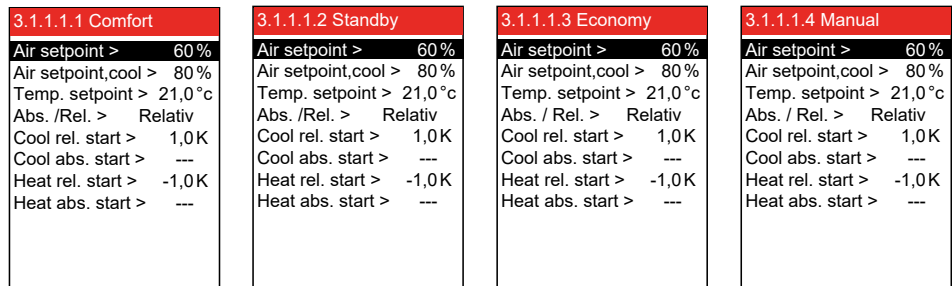

Menu 3.1.1.1.x - Air set point

Definition Used to set the desired ventilation level for the given indoor air quality level, from 0 to 100%. Press "OK" to end.

Menu 3.1.7 - limits menu See the range limits for fan output in Menu 3.1.7 in the HMI panel.

Menu 3.1.1.1.x - Temperature set point

Definition The required supply air or room temperature is set here. If "Absolute" indoor air quality level is selected (see next section), then the temperature set point can be selected (with 0.5 degree difference) within the configured "Cooling absolute start" and "Heating absolute start" ranges (for more details see relevant section).

Menu 3.1.8 - limits menu See the range limits for supply air temperature and room temperature in Menu 3.1.8 in the HMI panel.

Menu 3.1.1.1.x - Absolute/Relative temperature

Definition Used to select supply air or room temperature in relation to either absolute or relative temperature.

Absolute - Specify start temperature for heating coil or cooling unit.

Relative - Permitted temperature changes relative to the heating coil or cooling unit start temperature. See how the temperature variation follows when the set point is altered (diagram below, dotted lines).

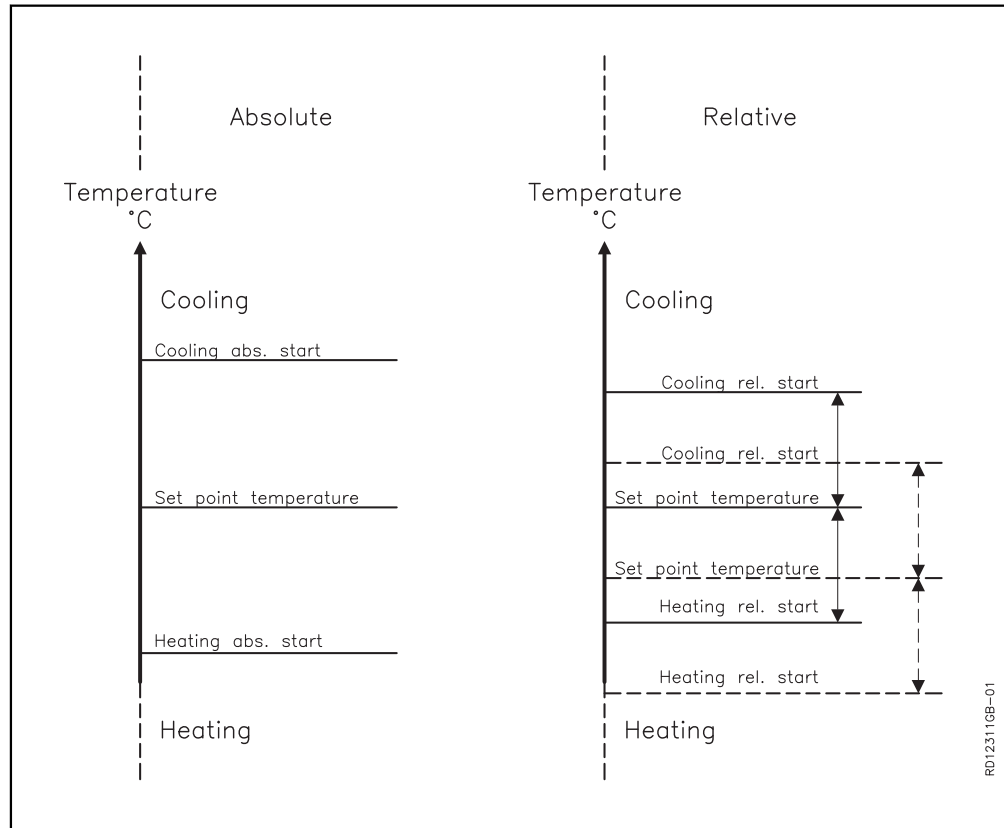

Menu 3.1.1.1.x - Cooling relative start

Definition This value determines when cooling must start in relation to the relative temperature. Low value = narrow temperature regulation range, leading to a comfortable indoor climate. High value = wider temperature regulation range, which provides cooling energy savings. Lower and upper limit is shown in the display.

Example If the required room temperature is 21°C, and Cooling Rel. start in the indoor air quality level menu is set to 3 K, the cooling unit will begin to operate on a warm day when the temperature exceeds 21°C + 3 K = 24°C.

Menu 3.1.1.1.x - Heating relative start

Definition This value determines when the heating coil must start in relation to the relative temperature. Low value = narrow temperature regulation range, leading to a comfortable indoor climate. High value = wider temperature regulation range, which saves energy because of lower heating requirements. Lower and upper limit is shown in the display.

Example If the required room temperature is 21°C, and Heating Rel. start in the indoor air quality level menu is set to -3 K, the heating coil will begin to operate on a cold day when the temperature falls below 21°C - 3 K = 18°C.

Menu 3.1.1.1.x - Cooling absolute start

Definition This value determines when cooling must start in relation to the absolute temperature. Lower and upper limit is shown in the display.

Example If Cooling abs. start is set to 24°C, the cooling unit will first start to operate when the temperature exceeds 24°C, even though the daily user has set the required room temperature to 21°C.

Menu 3.1.1.1.x - Heating absolute start

Definition This value determines when heating must start in relation to the absolute temperature. Lower and upper limit is shown in the display.

Example If Heating abs. start is set to 18°C, the heating coil will not start to operate until the temperature falls below 18°C, even though the daily user has set the required room temperature to 21°C.

Generally on temperature regulation

- Start by setting the max. and min. limits
- Set the temperature setpoint
- For other regulators, first set the max./min. and then the setpoint

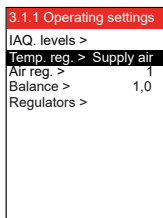

If temperature regulation is changed from Supply Air to Room, the functions on the next pages will be enabled, and invalid values will be adjusted to valid values. If temperature regulation is changed from Room to Supply Air, nothing will happen, as the limits for Room are always within the limits for Supply Air.

Menu 3.1.8 - Temperature limits

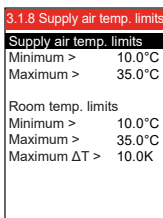

Limits, supply air temperature

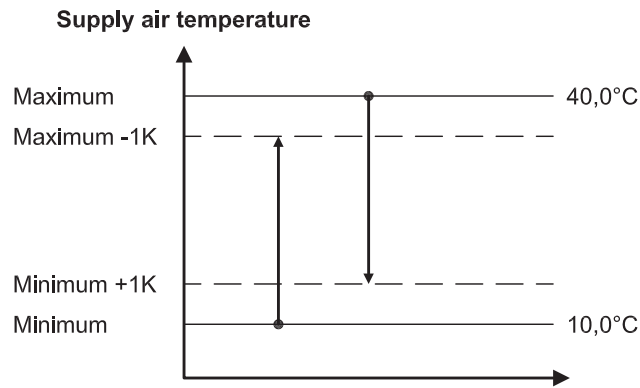

RD1.35396E-01

NB: Max. and Min. may never be set closer to each other than 1K.

If the following is selected	temperature will be controlled by...	NB:
supply air regulation	supply air temperature	Supply air temperature will never be higher than "Maximum" or lower than "Minimum".
room temperature regulation	extract air temperature or TSROOM	However, supply air temperature will never be higher than "Maximum" or lower than "Minimum".

Limits, room temperature

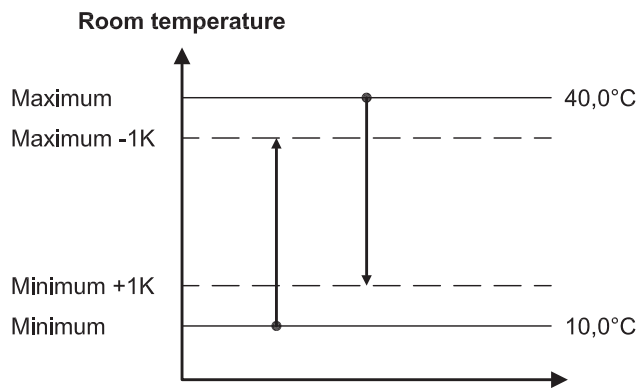

RD1.3547GB-01

NB: Max. and Min. may never be set closer to each other than 1K.

If	the following will be adjusted....
Supply air temp. maximum is set lower than the room temp. maximum.	The room temp. maximum is automatically reduced to the same value as the supply air temp. maximum.
The supply air temp. minimum is set higher than the room temp. minimum.	The room temp. minimum is automatically increased to the same value as the supply air temp. minimum.

Menu 3.1.1.1.x - Supply air regulation, absolute

3.1.1.1.x xxxxxxxx	
Air setpoint >	60%
Air setpoint.cool	80°C
Temp. setpoint >	21.0
Abs. / Rel. >	Absolute
Cool rel. start >	--°C
Cool abs. start >	26.0
Heat rel. start >	--°C
Heat abs. start >	21.0

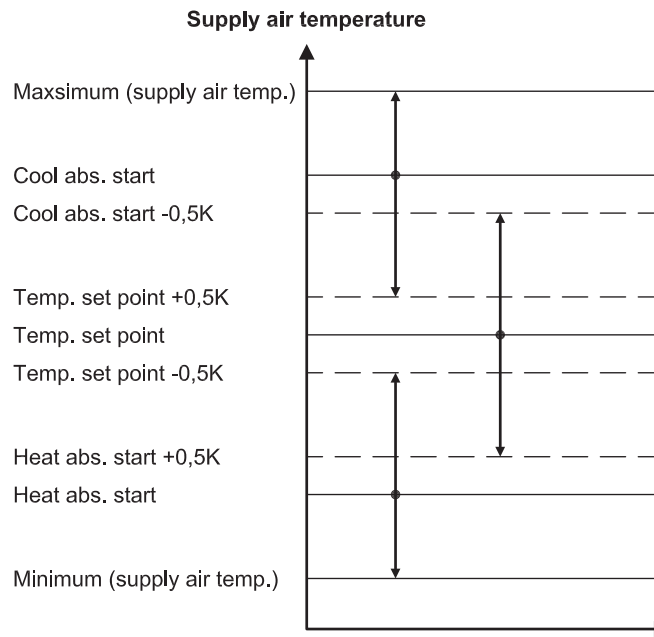

Note Temp. Setpoint can never be set closer to Heating abs. start or Cooling abs. start than 0.5 K.
 Heating abs. start and Cooling abs. start can never be set closer to each other than 1 K.

If	the following will be adjusted....
Maximum supply air temp. is set to a value lower than Cooling abs. start	Cooling abs. start will automatically reduce to the same value as Maximum supply air temp.
Cooling abs. start is set to a value lower than (Temp. setpoint + 0.5 K)	Temp. setpoint will automatically reduce to (Cooling abs. start - 0.5 K).
Minimum supply air temp. is set to a value higher than Heating abs. start	Heating abs. start will automatically rise to the same value as Minimum supply air temp.
Heating abs. start is set to a value higher than (Temp. setpoint - 0.5 K)	Temp. setpoint will automatically rise to (Heating abs. start + 0.5 K).

Menu 3.1.1.1.x - Room temperature regulation, absolute

3.1.1.1.x xxxxxxxx	
Air setpoint >	60%
Air setpoint,cool	80°C
Temp. setpoint >	21,0
Abs. / Rel. >	Absolute
Cool rel. start >	---°C
Cool abs. start >	26,0
Heat rel. start >	---°C
Heat abs. start >	21,0

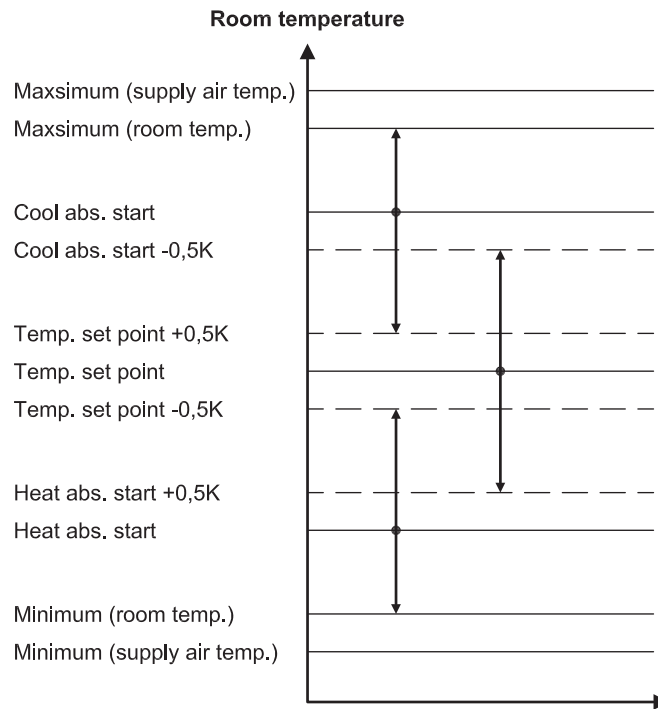

RD13549CB-01

Note

Temp. Setpoint can never be set closer to Heating abs. start or Cooling abs. start than 0.5 K.
 Heating abs. start and Cooling abs. start can never be set closer to each other than 1 K.

If	the following will be adjusted....
Maximum room temp. is set to a value lower than Cooling abs. start	Cooling abs. start will automatically reduce to the same value as Maximum room temp.
Cooling abs. start is set to a value lower than (Temp. setpoint + 0.5 K)	Temp. setpoint will automatically reduce to (Cooling abs. start - 0.5 K).
Minimum room temp. is set to a value higher than Heating abs. start	Heating abs. start will automatically rise to the same value as Minimum room temp.
Heating abs. start is set to a value higher than (Temp. setpoint - 0.5K)	Temp. setpoint will automatically rise to (Heating abs. start + 0.5 K).

Menu 3.1.1.1.x - Supply air regulation, relative

```

3.1.1.1.x xxxxxxxx
Air setpoint > 60%
Air setpoint,cool > 80%
Temp. setpoint > 21,0°C
Abs. / Rel. > Relativ
Cool rel. start > 1,0K
Cool abs. start > ---
Heat rel. start > -1,0K
Heat abs. start > ---
    
```

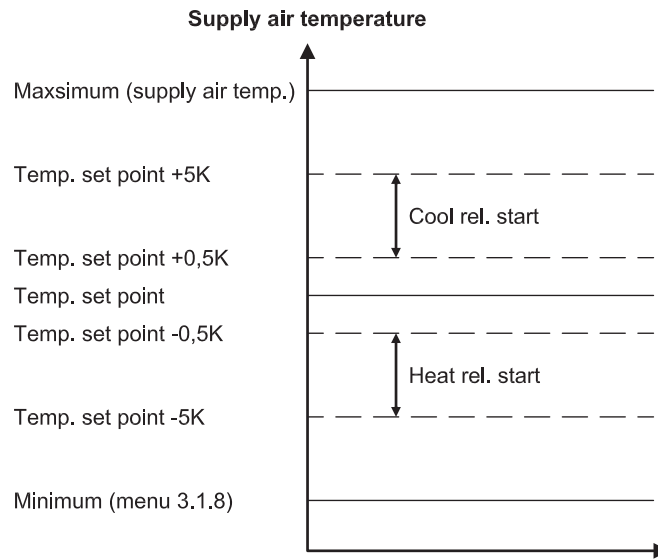

RD13550CB-01

If	the following will be adjusted....
Maximum supply air temp. is set to a value lower than (Temp. setpoint + Cooling rel. start) but higher than (Temp. setpoint + 0.5 K).	Cooling rel. start, automatically adjusted to (Maximum supply air temp. - Temp. setpoint).
Maximum supply air temp. is set to a value lower than (Temp. setpoint + Cooling rel. start) and less than (Temp. setpoint + 0.5 K).	Temp. setpoint automatically adjusted to (Maximum supply air temp. - 0.5 K). And Cooling rel. start to 0.5 K.
Minimum supply air temp. is set to a value higher than (Temp. setpoint + Heating rel. start) and greater than (Temp. setpoint - 0.5 K).	Heating rel. start, automatically adjusted to (Minimum supply air temp. - Temp. setpoint).
Minimum supply air temp. is set to a value higher than (Temp. setpoint + Heating rel. start) and less than (Temp. setpoint - 0.5 K).	Temp. setpoint automatically adjusted to (Minimum supply air temp. - 0.5 K). And Heat rel. start to -0.5 K.

Note for Cooling rel. start

The absolute min./max. values for Cooling rel. start are from 0.5 K to 5.0 K. If (Maximum supply air temp. - Temp. setpoint) is less than 5.0 K, the max. value for Cooling rel. start is changed to (Maximum supply air temp. - Temp. setpoint).

Note for Heating rel. start

The absolute min./max. values got Heating rel. start are from -5.0 K to -0.5 K. If (Minimum supply air temperature - Temp. setpoint) is greater than -5.0 K, the min. value for Heating rel. start is changed to (Minimum supply air temperature - Temp. setpoint).

Example 1:

No limitation from Minimum and Maximum supply air temp.:

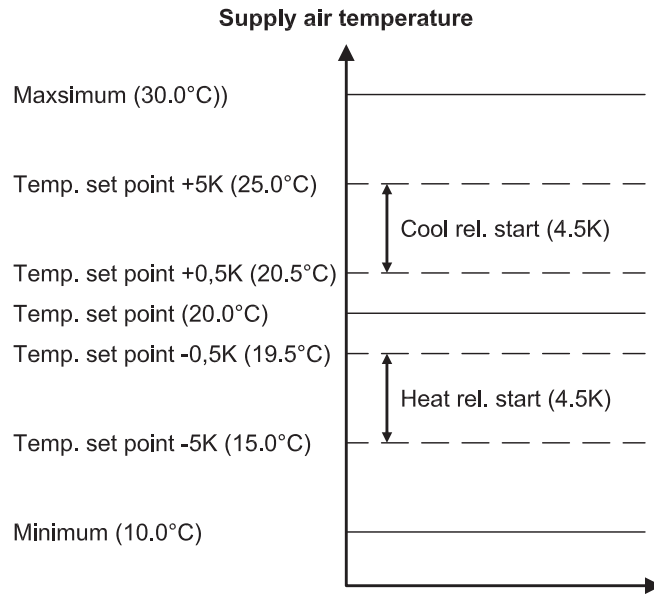

Example 2: Minimum and Maximum supply air temp. limit Cooling rel. start and Heating rel. start:

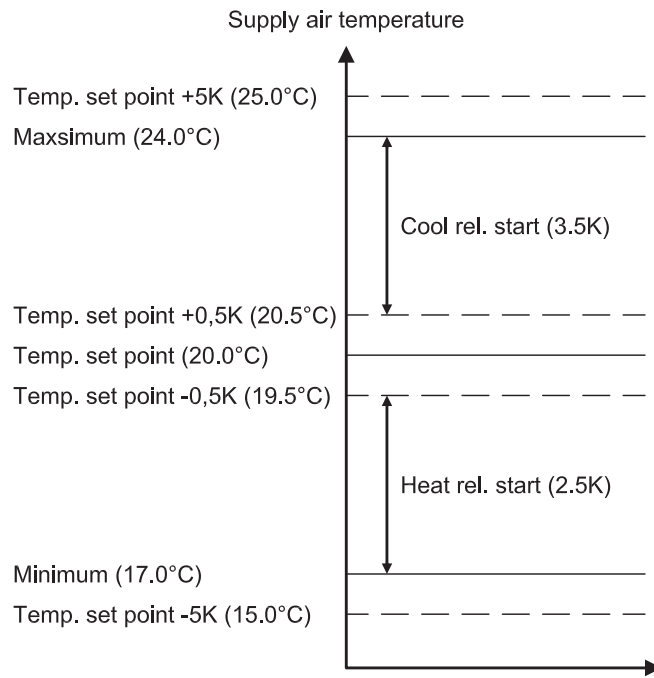

Menu 3.1.1.1.x - Room temperature regulation, relative

```

3.1.1.1.x xxxxxxxx
Air setpoint > 60%
Air setpoint,cool > 80%
Temp. setpoint > 21,0°C
Abs. / Rel. > Relativ
Cool rel. start > 1,0K
Cool abs. start > ---
Heat rel. start > -1,0K
Heat abs. start > ---
    
```

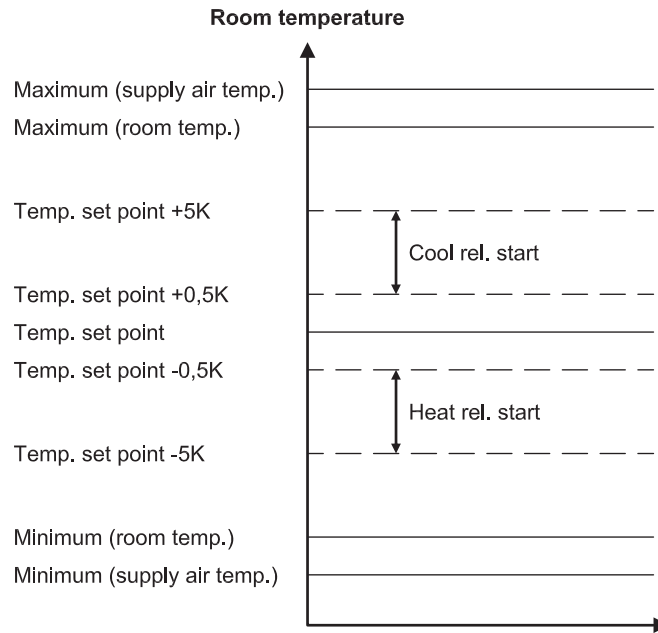

RD135536B-01

If	the following will be adjusted....
Maximum room temp. is set to a value lower than (Temp. setpoint + Cooling rel. start) but higher than (Temp. setpoint + 0.5 K).	Cooling rel. start, automatically adjusted to (Maximum room temp. - Temp. setpoint).
Maximum room temp. is set to a value lower than (Temp. setpoint + Cooling rel. start) and less than (Temp. setpoint + 0.5 K).	Temp. setpoint automatically (Maximum room temperature - 0.5 K). And Cooling rel. start to 0.5 K.
Minimum room temp. is set to a value higher than (Temp. setpoint + Heating rel. start) and greater than (Temp. setpoint - 0.5 K).	Heating rel. start, automatically adjusted to (Minimum room temp. - Temp. setpoint).
Minimum room temp. is set to a value higher than (Temp. setpoint + Heating rel. start) and less than (Temp. setpoint - 0.5 K).	Temp. setpoint automatically set to (Minimum room temperature + 0.5 K). And Heating rel. start to -0.5 K.

Note for Cooling rel. start The absolute min./max. values for Cooling rel. start are from 0.5 K to 5.0 K. If (Maximum room temperature - Temp. setpoint) is less than 5.0 K, the max. value for Cooling rel. start is changed to (Maximum room temperature - Temp. setpoint).

Note for Heating rel. start The absolute min./max. values for Heating rel. start are from -5.0 K to -0.5 K. If (Minimum room temp. - Temp. setpoint) is greater than -5.0 K, the max. value for Heating rel. start is changed to (Minimum room temp. - Temp. setpoint).

Example 1: No limitation from Minimum and Maximum room temp.:

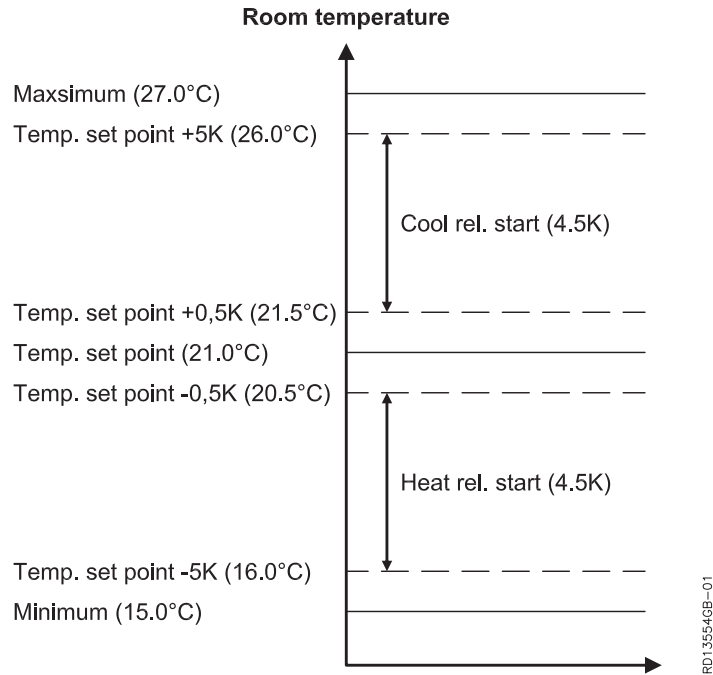

Example 2: Minimum and Maximum room temp. limit Cooling rel. start and Heating rel. start:

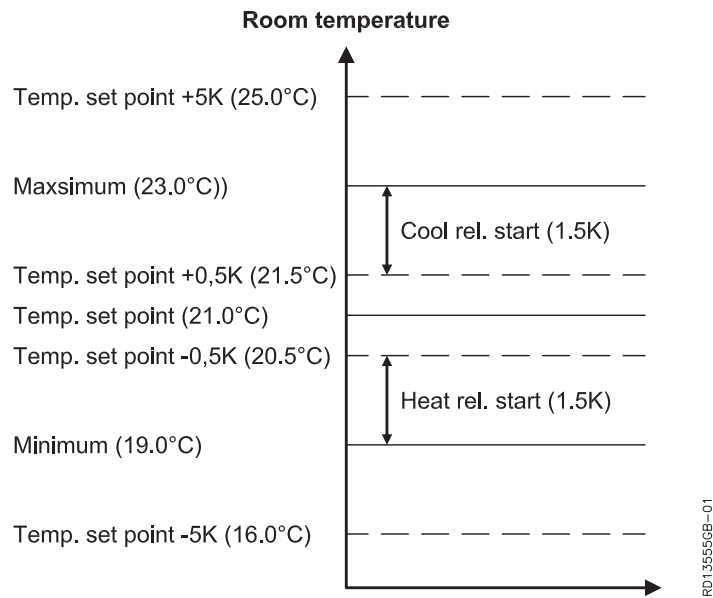

Menu 3.1.1 - Operation settings - Temperature regulation

Select one of two temperature regulation methods:

- Supply air temperature regulation
- Room temperature regulation (temperature regulated until the desired level is reached)

Temperature regulation is adjusted serially, using the following elements:

- Modulating heating coil(s).
- Any external cooling unit and cooling recovery

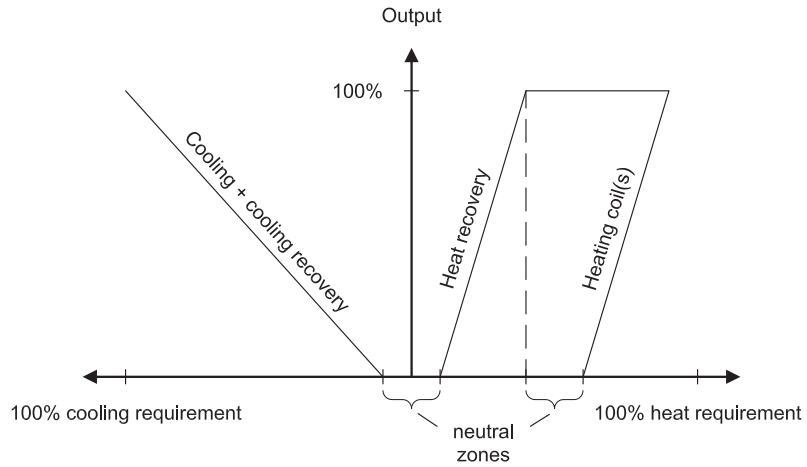

5406411GB-01

Select

Select one of the following:

- **Supply air regulation** - Typically used when the unit serves several rooms with different loads (sunlight, people, machines). The temperature is regulated by the built-in temperature sensor in the supply air spigot. If cooling and/or heating coil(s) are fitted, temperature is regulated from the nearest temperature sensor in the supply air duct.
- **Room temperature regulation** - Typically used when the unit serves several rooms with similar loads. The temperature is regulated by the built-in temperature sensor in the extract air spigot or via an external duct or room sensor (accessory).

Compensation

Compensation

Each form of regulation provides different options for set point compensation. See the next sections.

In general

Compensation of the airflow and temperature is carried out by a sensor sending signals to the control system, which then reduces or increases airflow and temperature if required. Airflow and temperature are always compensated, no matter which indoor air quality level the unit is set to.

Menu 3.1.2 - Air compensation

Airflow compensation

Airflow compensation can be carried out on the basis of the following:

1. **CO₂ compensation** - Air quality in the room (CO₂ content in air)
2. **Humidity compensation** - Air humidity in the room
3. **Airflow reduction** - reducing the airflow in the event of falling supply air temperature
4. **Outdoor air compensation** - reduces airflow in the event of falling outdoor temperature falls

Note

- All compensation options can be connected and active at the same time, and may influence the control airflow
- CO₂ and humidity compensation cannot be activated if air regulation method 8 is selected.

Autostart with timer operation

If the weekly schedule is at OFF and either the CO₂ or the humidity level exceeds the starting limit for CO₂ or humidity compensation, the VEX/CX will automatically start up using the settings from indoor climate level "Economy".

Menu 3.1.2.1 - CO₂ compensation

Requirements

A CO₂ sensor (CO2B or other CO₂ sensor via AI SPARE, MIO-CO2, BMS) must be mounted to allow selection of CO₂ compensation of the airflow. Connection of the sensor is described in the additional instructions accompanying the sensor.

Function

When the control system is operating, this function can be used to increase the airflow in the event of increasing CO₂ levels.

NB:

- Cannot be activated if air regulation method 8 is selected.

Selection of CO₂ compensation

Activate in Menu 3.1.3.2.

Example

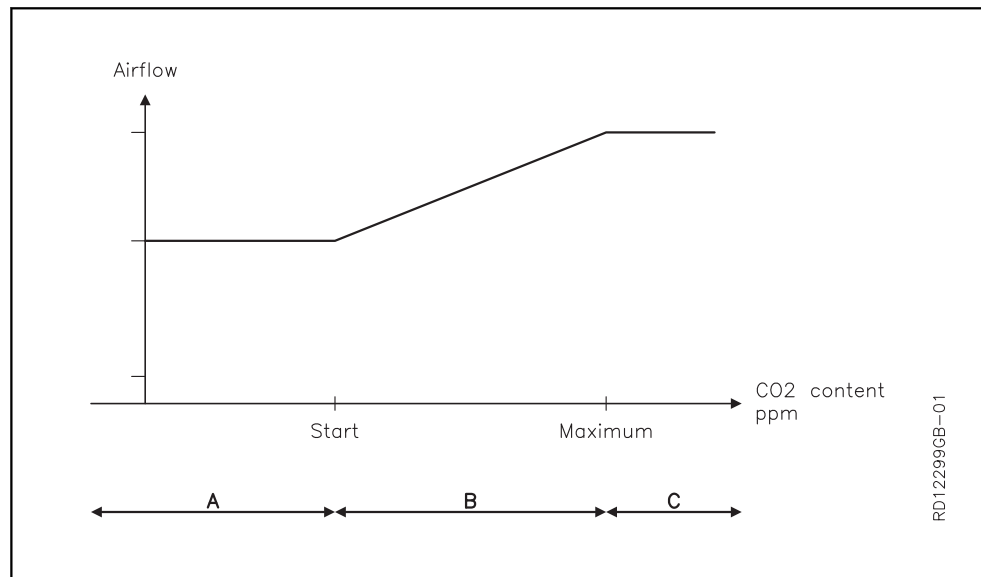

	CO ₂ concentration in the air is ...	Airflow...
A	less than Start	is the same as set value
B	between Start and Maximum	increases gradually to a high level, depending on the current CO ₂ level
C	greater than Maximum	is increased to maximum air replacement

Menu 3.1.2.2 - Humidity compensation of airflow

Requirements A humidity sensor (RHB, MIO-RH, BMS) must be fitted in order to be able to select humidity compensation of the airflow. The sensor must be installed in the room in which you wish to make compensation, such as a bathroom. Connection of the sensor is described in the additional instructions accompanying the sensor.

Function When the control system is operating, this function increases airflow in the event of increasing humidity levels.

NB:

- Cannot be activated if air regulation method 8 is selected.

Selecting humidity compensation Activate in Menu 3.1.2.2.

Example

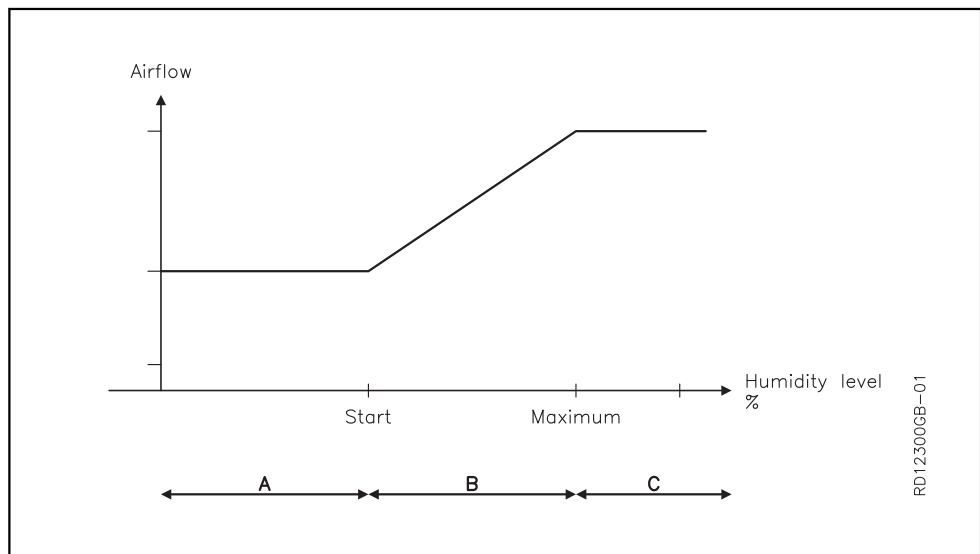

	Air humidity level is...	Airflow...
A	less than Start	is the same as set value
B	between Start and Maximum	increases gradually to a high value, depending on the current air humidity (RH level)
C	greater than Maximum	is increased to maximum air replacement

Menu 3.1.2.3 - Airflow reduction

Function When the control system is operating, this function reduces the required supply air airflow in the event of falling supply air temperature. This makes it possible to maintain the required supply air temperature longer.

Selecting airflow reduction Activate in Menu 3.1.2.3.

Example

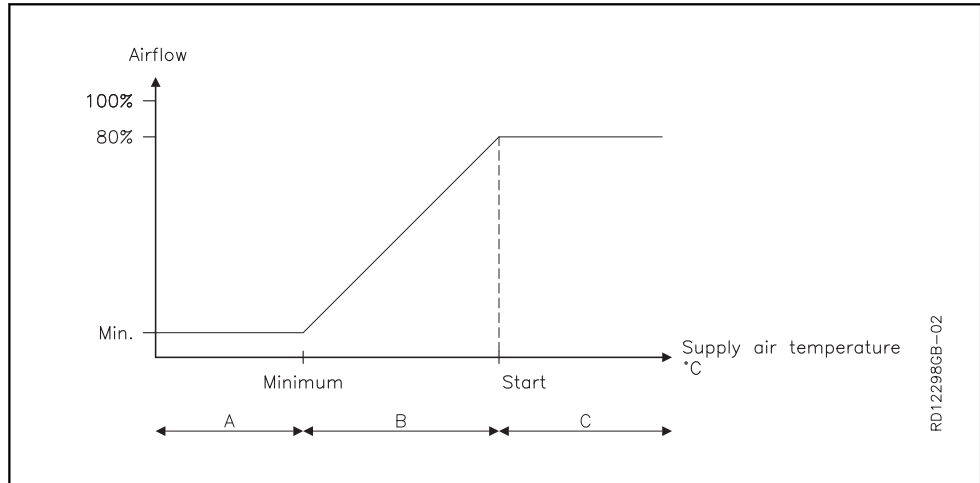

	Supply air temperature is...	Airflow...
A	Lower than Minimum	Equivalent to Minimum (or lowest) airflow
B	Between Minimum and Start	increases gradually between minimum airflow and the set airflow
C	Greater than Start	Equivalent to set airflow

NB:

- When this function is active, a large imbalance can occur in the airflows, as only the supply airflow is reduced while the extract airflow is maintained at the required level
- This function overrides CO₂ and RH sensors.

Menu 3.1.2.4 - Outdoor compensation of airflow

Function

When the control system is operating, this function reduces the required airflow in the event of falling outdoor air temperature.

Selecting outdoor compensation

Activate in Menu 3.1.2.4.

Example

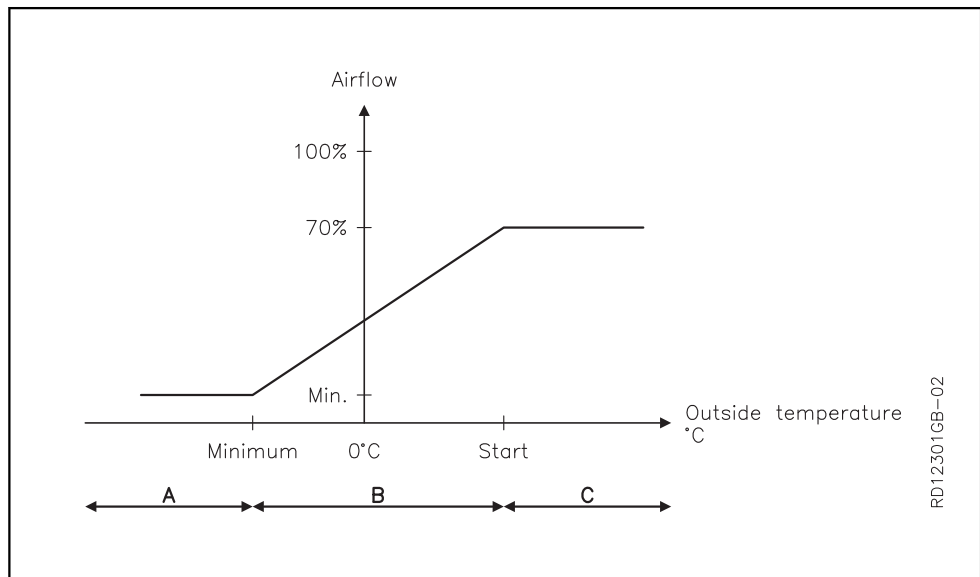

	Outdoor air temperature is	Airflow...
A	Lower than Minimum	Equivalent to Minimum airflow
B	Between Minimum and Start	increases gradually between minimum airflow and the set airflow
C	Greater than Start	Equivalent to set airflow

Menu 3.1.3 - Temperature compensation

Menu 3.1.3.1 - Outdoor air temperature compensation

Function The set point for the supply air temperature can be increased if outdoor air temperatures are low. The supply air temperature can be lowered if outdoor air temperatures are high.

NB: This function is active only if supply air temperature regulation is activated for the indoor air quality level in Menu 3.1.1 (Operation settings -> Temp. reg. -> Supply air).

Selecting outdoor air temperature compensation Activate in Menu 3.1.3.1.

Outdoor air compensation Outdoor air compensation aims to compensate for the energy that a building either radiates when the outdoor air temperature is low, or absorbs when the outdoor air temperature is high, thus maintaining a constant temperature in the building. If you require outdoor air compensation, select values as indicated below.

Example

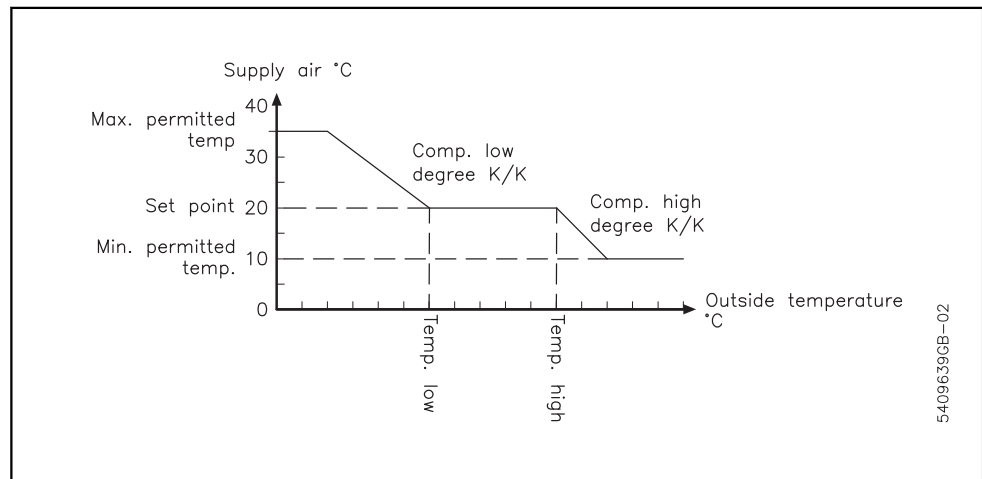

Supply air temperature is	action
cold when outdoor air temperature low	'Temp. low and/or "Comp. low' raised.
warm when outdoor air temperature low	'Temp. low and/or "Comp. low' lowered.
cold when outdoor air temperature high	'Temp. high' and/or "Comp. high' raised
warm when outdoor air temperature high	'Temp. high' and/or 'Comp. high' lowered.

Menu 3.1.3.2 - Summertime compensation

Function The room temperature can be raised if outdoor air temperatures are high.

NB: Summertime compensation is active only if room temperature regulation is activated for the indoor air quality level in Menu 3.1.1 (Operation settings -> Temp. reg. -> Room).

Selecting summertime compensation Activate in Menu 3.1.3.2.

Summertime compensation Summertime compensation raises the room temperature when the temperature outside is high, to reduce the temperature difference people experience when entering and exiting the building. The result is that indoor air quality feels comfortable even when people are wearing summer clothing. If summertime compensation is required, select values as indicated below.

Example

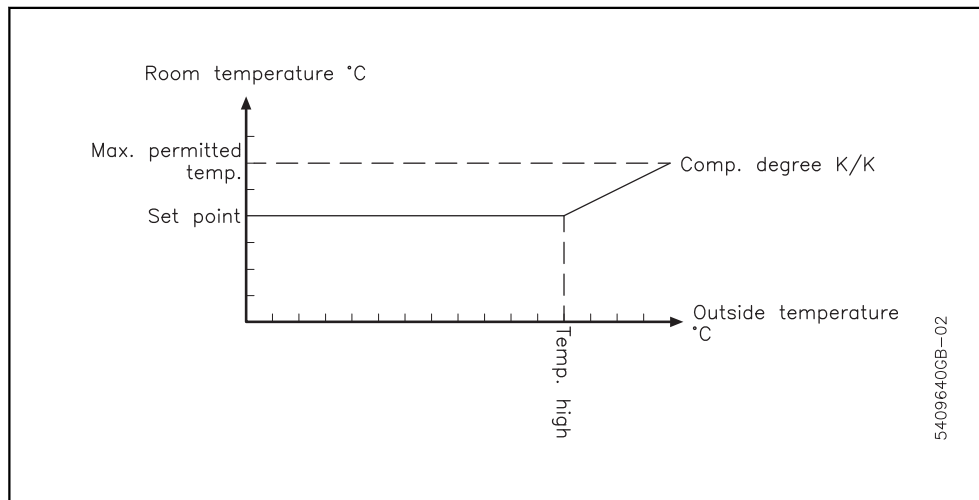

Room temperature is too...	action
cold when outdoor air temperature high	'Temp. high' lowered and/or 'Comp. grad' raised
warm when outdoor air temperature high	'Temp. high' raised and/or 'Comp. grad' lowered

Menu 3.1.4 + Menu 8.1 - Filter (monitoring in case of pressure)

In general The pressure across outdoor air and extract air filters is monitored by sensors close to the filters. A soiled filter will generate a warning signal, and then an alarm signal, to indicate that it needs replacing.

3.1.4 Filter	
Current pressure:	
Outdoor air	0 Pa
Extract air	0 Pa
Warning:	
Outdoor air >	135 Pa
Extract air >	135 Pa
Alarm:	
Outdoor air >	150 Pa
Extract air >	150 Pa

Current pressure The current pressure drop across the outdoor air and extract air filters is displayed.

Warning Set the supply air and extract air soiled-filter warning level here.

Alarm Set the outdoor air and extract air replace-filter alarm level here.

Menu 8.1 The same settings that can be configured in Menu 3.1.4 can be configured here.

Menu 3.1.5 - Night-time cooling

Function Night-time cooling is typically used during hot summer periods in buildings which are unoccupied during the night. During hot periods it may be desirable to cool down the building during the night. The aim is to reduce the energy required for cooling during the day by exploiting the lower night-time temperature combined with high air replacement. Night-time cooling involves high airflow ventilation, without turning on the cooling unit.

Conditions for night-time cooling The control system performs a five-minute "test run" to check the following conditions are met before activating the night-time cooling function:

- Outdoor air temperature must be lower than the room temperature
- Prior to initiating night-time cooling, there must not have been any heating requirement within a time interval defined in the night-time cooling menu
- Heating coils must not be active during night-time cooling (does not apply during the test run)
- As a factory default setting (set in Menu 3.1.5.9 Operation blocking), the night-time cooling function can only be activated if Comfort operation is scheduled for the following day
- Extract air temperature must be higher than the set point

Conditions not met If the above conditions are not met at the Start time, the control system will perform a test run once an hour (until an hour before the Stop time) to check whether the conditions for starting night-time cooling can now be met.

Override The following can override the night-time cooling function:

- If the system is controlled by a PIR sensor.
- If the Manual indoor air quality level is active

NB: for third-party equipment with damper



If third-party equipment with damper is fitted to the unit, check that it does not impeded air changes when night-time cooling is activated!

3.1.5 Night-time cooling

Active period > Summer
 Set point > 18°C
 Min. supply temp. > 10°C
 ΔT max. > 6K
 ΔT min. > 3K
 Start time > 00:00
 Stop time > 06:00
 HC blocking > 60hr
 Permit night-time cooling >

3.1.5.9 Permit night-time cooling

Comfort > Yes
 Standby > No
 Economy > No

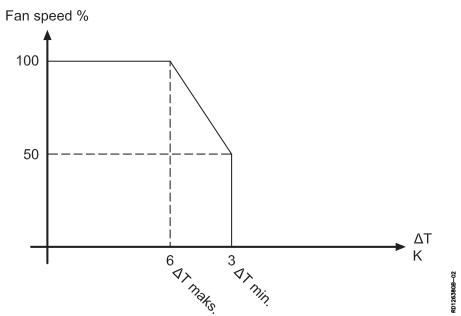
Lines in Menu 3.1.5	Function	Factory setting
Operating period	<ul style="list-style-type: none"> Select "None" to deactivate night-time cooling. Select "Always" to activate night-time cooling all year round. Select "Summer" to activate night-time cooling during summertime. See summer/wintertime icon on the front of the HMI. 	Summer
Setpoint	Set point for desired room temperature during night-time cooling	18°C
Min. supply air temp.	If the selected minimum supply air temperature cannot be met, night-time cooling stops	10°C
ΔT max.	Setting for temperature difference between outdoor air and extract air* when the unit operates with 100% fan speed. 	6K
ΔT min.	Setting for temperature difference between outdoor air and extract air*, when the unit operates with 50% fan speed. From ΔTmin. to ΔTmax. the fan speed increases from 50% to 100%.	3K
Start time	Start time for night-time cooling	00:00
Stop time	Stop time for night-time cooling	06:00
HC blocking (heating coil blocking)	Time interval prior to night-time cooling during which there must not have been any heating requirement	60 hr
Permit night-time cooling	Menu 3.1.5.9 is used to configure conditions under which night-time cooling is activated. This menu is dependent on the timer program for the following day	Comfort > Yes Standby > No Economy > No

*The extract air temperature is always used, regardless of whether a room temperature sensor is installed for the system.

Menu 3.1.5.9 - Permit night-time cooling

If	is set to	and the indoor air quality level is	is activated
Comfort/Standby/Economy	Yes	included in the timer program for the following day	night-time cooling
Comfort/Standby/Economy	Yes	not included in the timer program for the following day	no night-time cooling
Comfort/Standby/Economy	No	included in the timer program for the following day	night-time cooling
Comfort/Standby/Economy	No	not included in the timer program for the following day	night-time cooling

Menu 3.1.6 - Cold recovery

Selecting cold recovery Activate in Menu 3.1.6.

Start-up (Start limit) Cold recovery starts when the configured temperature difference between the room temperature and outdoor air temperature is reached. The factory setting is 3K. Cold recovery operates at 100% when it is engaged.

Stop Cold recovery ceases again when the temperature difference between the room temperature and outdoor air temperature is 1K below the configured start limit.

Operation with CCW, MXCU, MXHP or MCOCW Recommended that cold recovery is activated if CCW, MXCU, MXHP or MCOCW cooling used.

Menu 3.1.7 - Fan limits

Function Configuration of minimum and maximum fan output limits (supply air and extract air) as percentages. These are the absolute minimum and maximum fan output limits, i.e. all other menus where fan output can be changed will be limited by the absolute settings.

Example If a user selects maximum fan rpm in the user menu (100% ventilation), fan output will still never exceed the value set in this menu.

Menu 3.1.8 - Temperature limits for supply air and room

Function Configuration of minimum and maximum supply air temperature limits. These are the absolute minimum and maximum supply air temperature limits, i.e. all other menus where supply air temperature can be changed will be limited by the absolute settings.

Example If a user selects maximum temperature in the user menu, the temperature will never exceed the value set in this menu.

Supply air temperature limits

Setting	Go to menu	NB:
Lowest permitted supply air temperature	3.1.8	Range: 10.0°C..0.250.0°C
Highest permitted supply air temperature		Range: 30.0°C..0.40.0°C

NB: The settings above must only be changed if special circumstances require it. Otherwise, the factory settings can be used.

Room temperature limits**Function**

Configuration of minimum and maximum room temperature limits. These are the absolute minimum and maximum room temperature limits, i.e. all other menus where room temperature can be changed will be limited by these settings.

Example

If a user selects maximum temperature in the user menu, the temperature will never exceed the value set in this menu.

Room temperature limits

Setting	Go to menu	NB:
Lowest permitted room temperature	3.1.8	Range: 10.0–34.0°C
Highest permitted room temperature		Range: 11.0°C..0.35.0°C
ΔT (difference between supply air and extract air temperature)		Allows for prevention of condensation on supply air fixtures and down draught. Range: ΔT : 2.0K...15.0K

NB: The settings above must only be changed if special circumstances require it. Otherwise, the factory settings can be used.

Menu 3.1.9 - MXHP settings

For information on setting the MXHP module, please consult the instructions for the module.

Menu 3.1.10 - MCOCW settings

For information on setting the MCOCW module, please consult the instructions for the module.

Menu 5 - Time and weekly plan

Menu 5.1 - Date and time

This menu is used to set the current date, day and time.

Menu 5.2 - Weekly plan

Plan type

When "Timer" operation has been selected in Menu 1, the weekly plan must be configured. Select one of the following three plan types:

Plan type	Use when	Program interval
Day	Different programs are required for different weekdays.	Monday, Tuesday, Wednesday, Thursday, Friday, Saturday, Sunday
Week	The same program is required for all days of the week.	Monday to Sunday
5/2	One program is required for Monday to Friday, and another program for weekends.	Weekdays: Monday to Friday, Weekend: Saturday and Sunday

Editing

Menu	Action				
<table border="1" style="width: 100%; border-collapse: collapse;"> <tr> <td style="width: 25%; padding: 2px;"> 5 Time and weekly plan Date and time > Weekly plan > </td> <td style="width: 25%; padding: 2px;"> 5.2 Weekly plan Plan type > 5/2 Change > </td> <td style="width: 25%; padding: 2px;"> 5.2.2 Change Weekday > Weekend > </td> <td style="width: 25%; padding: 2px;"> 5.2.2.1 Weekday 1 IAQ. level > Standby 1 Time of day > 06:00 2 IAQ. level > Comfort 2 Time of day > 07:30 3 IAQ. level > Economy 3 Time of day > 17:30 4 IAQ. level > OFF 4 Time of day > 00:00 5 IAQ. level > Inactive 5 Time of day > --:-- </td> </tr> </table>	5 Time and weekly plan Date and time > Weekly plan >	5.2 Weekly plan Plan type > 5/2 Change >	5.2.2 Change Weekday > Weekend >	5.2.2.1 Weekday 1 IAQ. level > Standby 1 Time of day > 06:00 2 IAQ. level > Comfort 2 Time of day > 07:30 3 IAQ. level > Economy 3 Time of day > 17:30 4 IAQ. level > OFF 4 Time of day > 00:00 5 IAQ. level > Inactive 5 Time of day > --:--	
5 Time and weekly plan Date and time > Weekly plan >	5.2 Weekly plan Plan type > 5/2 Change >	5.2.2 Change Weekday > Weekend >	5.2.2.1 Weekday 1 IAQ. level > Standby 1 Time of day > 06:00 2 IAQ. level > Comfort 2 Time of day > 07:30 3 IAQ. level > Economy 3 Time of day > 17:30 4 IAQ. level > OFF 4 Time of day > 00:00 5 IAQ. level > Inactive 5 Time of day > --:--		
5.2	Select "Weekly plan"				
5.2.2	Select "Editing"				
<ul style="list-style-type: none"> If plan type "Week" is selected 	start editing in Menu 5.2.2				
<ul style="list-style-type: none"> If plan type "Day" or "5/2" is selected 	Go to Menu 5.2.2.1 and start editing				
5.2.2 or 5.2.2.1	Go to 1 Indoor air quality level - select level. Select one of the following: Inactive, OFF, Comfort, Standby, Economy. Go to 1 Time - Select the start time for indoor air quality level 1 Complete the rest of the program in the same way. See programming example below				

Program example

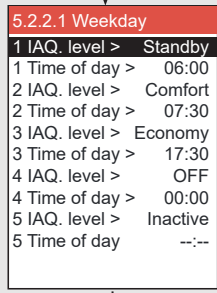

Time interval	Indoor air quality level
06:00 - 07:30	Standby
07:30 - 17:30	Comfort
17:30 - 00:00	Economy
00:00 - 06:00	OFF

Menu 7 - Safety functions

Menu 7.1 - Fire alarm

Four operating modes

There are four different operating modes in the event of a fire. The selected operating mode must meet regulatory standards.

Go to Menu 7 and select mode	Operating mode	VEX320-330 C+H, CX340/350, VEX310T-350T Internal damper BP1	VEX340 Internal damper BP1, BP2 and RAD*)	VEX350/360 Internal dampers BP1 and BP2*)	VEX370 Internal damper BP1, BP2 and BP3
1 (factory setting)	Supply air and extract air stopped	BP1 closed	BP1 and BP2 are closed RAD is closed	BP1 and BP2 are closed	BP1, BP2 and BP3 are closed
2	Supply air 100% and extract air stopped	BP1 open	BP1 and BP2 are closed RAD is closed	BP1 in case of extract air is closed and BP2 in case of supply air is open	BP1 in case of extract air is closed and BP2 and BP3 in case of supply air are open
3	Supply air stopped and extract air 100%	BP1 closed	BP1 and BP2 are open RAD is closed	BP1 in case of extract air is open and BP2 in case of supply air is closed	BP1 in case of extract air is open and BP2 and BP3 in case of supply air are closed
4	Supply and extract air 100%	BP1 open	BP1 and BP2 are open RAD is closed	BP1 and BP2 are open	BP1, BP2 and BP3 are open

*) BP1=Bypass damper 1, BP2=Bypass damper 2, BP3=Bypass damper 3, RAD=Return air damper

Activation of operating mode

The selected operating mode under the function "Fire alarm" is activated if the closed circuit in any of the two inputs Fire and AUX IN on EXact2 main board are broken.

The inputs allow the connection of:

- Smoke detectors
- Fire thermostats (e.g. BT40, BT70 or BT70)
- BMS
- Fire control system

If an input is not used, a jumper must be used (see Electrical Installation Guide)

Menu 7.2 - Frost protection of HCW

Setting of frost protection

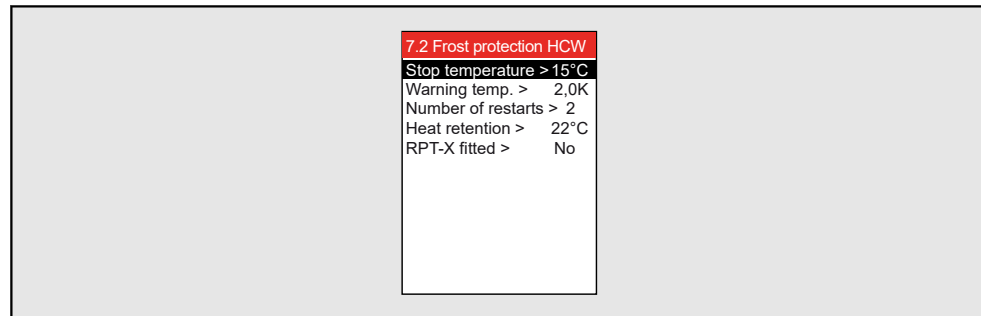

Menu line	Function	Action
Stop temperature	Selection of return water temperature setting at which the unit stops and the motor valve fully opens. See table below	<ul style="list-style-type: none"> • Select the required stop temperature The coldest temperature sensor (TE-RPT or TE-RPT-X) will be utilised. See the temperatures in menu 2.6
Warning temperature	Selection of return water temperature setting at which airflow is reduced	<ul style="list-style-type: none"> • Select the temperature relative to the stop temperature (ΔT) which will generate a frost damage warning and reduce airflow
Number of restarts	Up to five restarts may be selected	<ul style="list-style-type: none"> • Select the maximum number of restarts permitted in an hour before an alarm is triggered Manual reset is activated by selecting "0" for no. of restarts
Constant temperature	In the case of a unit being stopped, a selected "constant heating temperature" is maintained to ensure that the heating pipes stay warm.	<ul style="list-style-type: none"> • Select the required constant heating temperature
RPT-X fitted	State if RPT-X is fitted	<ul style="list-style-type: none"> • If an RPT-X is not required, it may be removed
MVM/CP time	Time before MVM valve closes and circulation pump stops when stop temp. or number of restarts has been exceeded.	<ul style="list-style-type: none"> • Options: <ul style="list-style-type: none"> - 5 minutes - ∞ (never)

Stop temperature

If the return water temperature does the following within a five-minute period	and total number of restarts	Then
Rises above the constant heating temperature	> 0	Airflow is increased again to the normal operating level
Remains below the constant heating temperature	> 0	5 min: After 5 minutes, the MVM valve will close and the CP will stop. The alarm must be reset manually in menu 4. ∞: MVM valve 100% open and circulation pump continues operation.

Note

The frost protection function is only active when the outdoor air temperature is below 10°C.

Menu 7.3 - Frost protection heat exchanger

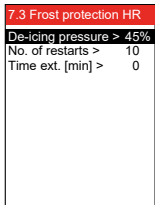

In the menu, select the increase in pressure loss as a percentage (relative to clean exchanger) that must activate de-icing. The de-icing pressure can be set between 25–60%. It is recommended that the factory-set de-icing pressure of 45% (based on experience) should only be changed in special circumstances.



The de-icing icon is displayed in the user menu every time the unit runs de-icing.

If it transpires that the unit is operating...	it may be advantageous increase the de-icing pressure
with very short de-icing intervals	increase the de-icing pressure above 45%
with very long de-icing intervals	lower the de-icing pressure below 45%

Number of restarts

Select the total number of restarts allowed after the unit has been in hibernation (hibernation period two hours). OFF = There is no upper limit to the total number of restarts. In countries/areas where there may be long periods of low temperatures, a higher number of restarts (possibly OFF) than the factory setting should be selected.

T_{ice} (VEX320-330)

T_{ice}

Select from the menu the temperature at which de-icing is activated.

Recommended de-icing, T_{ice}

Home: T_{ice} = 0°C
Office/school: T_{ice} = -5°C

Fine adjustment of T_{ice}

As ice formation in the counter flow heat exchanger is strongly dependent on the humidity content of the extract air, the air temperatures and the air volumes, it is recommended that the unit is fine-adjusted once it has been brought into use. Fine adjustment of T_{ice} can reduce annual energy consumption.

How to carry out fine adjustment

Check whether ice is present when the  icon appears in the display. If no ice is apparent when the icon appears, T_{ice} can advantageously be lowered by 1K. The unit must be monitored for a period and ice checks in the heat exchanger regularly made. Once T_{ice} has been reduced to the optimum for the building/condi-

tions, there will be ice present when the  icon appears.

Alarm 32024

If the unit displays alarm no. 32024 "Frozen counter flow heat exchanger", T_{ice} may be increased by 1K-2K.

Excessive periods with reduced supply air

If de-icing of the heat exchanger leads to undesirably reduced supply air for long

periods ( icon appears frequently and for long periods), it is recommended that the heating coil output be increased:

1. Increase supply temperature (TE-SPT)
2. If the heating coil is an HCW small, upgrade it to a larger one
3. If the heating coil is an HCE04, upgrade it to a larger one

5. Operation

Menu 2 - Operating readings

In general

All of the operating parameters can be read in Menu 2. ___ is shown in the menu if a given unit is not fitted.

Menu 2.1 - Air temperatures

2 Operating readings	2.1 Air temperature	2.1.1 Setp. regulators
Air temperature >	Setp. regulators >	Room 0,0
Airflows >	Supply air (room) 21,3°C	Heat recovery 10,0
MC parameters >	Extract air (room) 11,2°C	Cooling unit 10,0
Temp. reg. units >	Outdoor air 15,7°C	Heating unit 10,0
Pressure >	Exhaust air 0,0°C	Compensation:
Heating coil >	Supply air (VEX) 18,5°C	Outdoor temp. Inactive
CH cooling unit	Supply air (CU) ---	Summer Inactive
CCW	Room sensor 0,0°C	
CU cooling unit	Heating coil 0,0°C	
MXCU	Cooling unit ---	
MXHP >		
Timers >		
CO2/RH sensors >		
ALC		

Temperature sensor positioning - VEX340

2.1 Air temperature	
Setp. regulators >	
A —	Supply air (room) 21,3°C
B —	Extract air (room) 11,2°C
C —	Outdoor air 15,7°C
D —	Exhaust air 0,0°C
E —	Supply air (VEX) 18,5°C
	Supply air (CU) ---
*)G —	Room sensor 0,0°C
H —	Heating coil 0,0°C
J —	Cooling unit ---

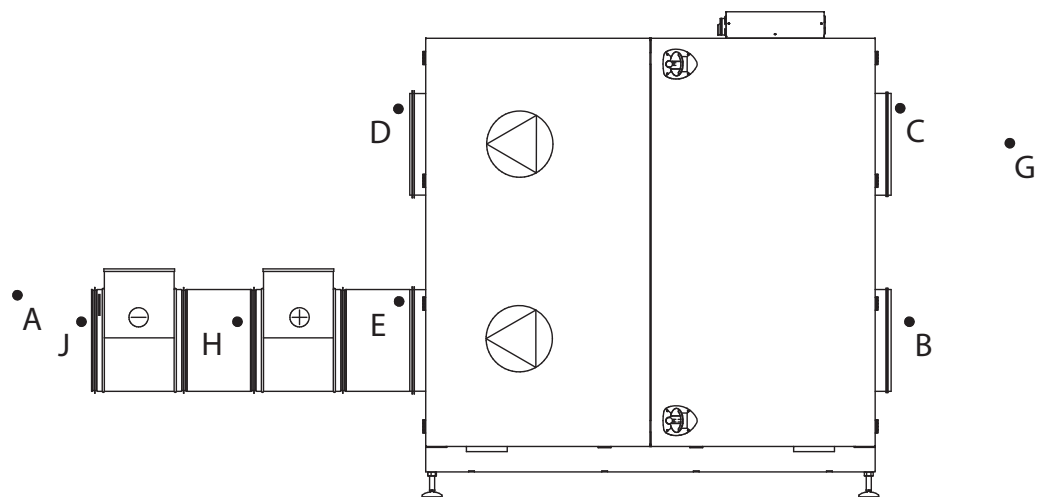

*Measured if room sensor TS-ROOM or if the duct sensor TS-DUCT is fitted.

Example VEX300 + Chiller

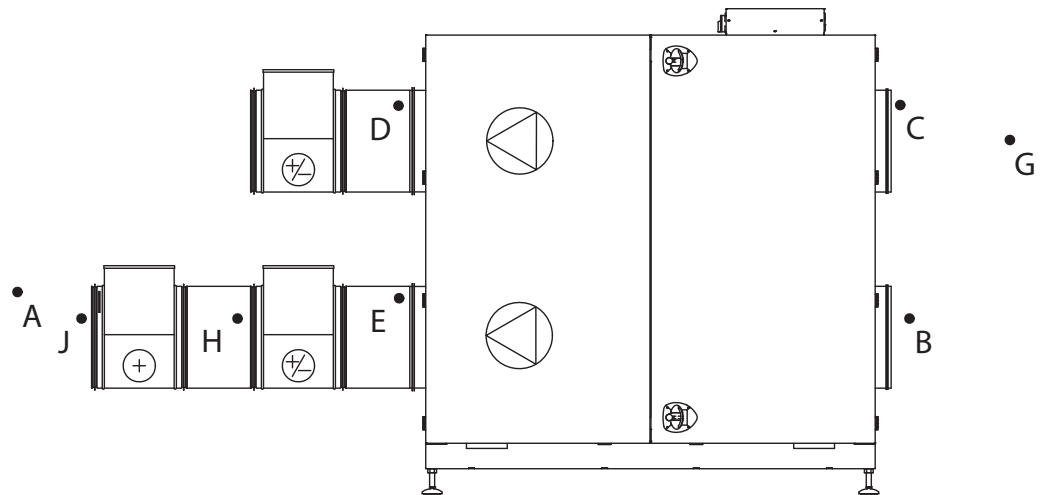

Diagrams

See appendix 1 for VEX320/330/340/350/360/370-CX340/350-VEX310T-350T.

Menu 2.1.1 - Set points for regulators

2.1.1 Setp. regulators	
Room	0,0
Heat recovery	10,0
Cooling unit	10,0
Heating unit	10,0
Compensation:	
Outdoor temp.	Inactive
Summer	Inactive

This menu shows set points for:

- The room temperature regulator
 - The heat recovery regulator
 - The cooling regulator
 - The heating unit regulator
- Compensations:
- List of compensations (active/inactive)

Menu 2.2 - Airflows

2.2 Airflows	
Supply air	71l/s
Supply air	282m ³ /h
Extract air	71l/s
Extract air	282m ³ /h
Return air	0l/s
Return air	0m ³ /h

The menu shows the airflows (converted to airflows at 20°C) specified in l/s and m³/h. Uncertainty for the measured airflow is less than ±8%.

NB: Return air shown only for VEX340.

Menu 2.3 - Motor controller parameters (MC parameters)

2.3 MC parameters	
Supply air:	
Maximum	50.0Hz
Set point	30.0Hz
Minimum	14.0Hz
Extract air:	
Maximum	50.0Hz
Set point	30.0Hz
Minimum	14.0Hz

FC: The menu shows maximum and minimum frequencies. The set point shows the current frequency at the relevant fan (e.g. 30 Hz).

2.3 MC parameters	
Supply air:	
Maximum	2901RPM
Set point	1500RPM
Minimum	316RPM
Extract air:	
Maximum	2901RPM
Set point	1500RPM
Minimum	361RPM

EC: The menu shows maximum and minimum rpm. The set point shows the total rpm (e.g. 1,000 rpm)

2.3 MC parameters	
Supply air:	
Maximum	10.0V
Set point	5.6V
Minimum	1.4V
Extract air:	
Maximum	10.0V
Set point	5.6V
Minimum	1.4V

Analogue: The menu shows maximum and minimum voltage. The setpoint shows control voltage, e.g. 4.6V.

Menu 2.4 - Temperature regulating units

2.4 Temp. reg. units	
Heat recovery	100.0%
Heating unit	0.0%
Heat pump unit	0.0%
Cooling unit	0.0%
Cooling recovery	0.0%
De-icing	Inactive
De-icing stage	---
Hibernation	---
Rise in press. drop	1%
Tice	0.1%

The menu shows the current:

- heat recovery
- output of heating coil (if installed)
- output of heat pump unit (if installed)
- output of cooling unit (if installed)
- cold recovery (0% or 100%)
- If de-icing is active or inactive
- De-icing step. See table below
- Count-down (in seconds) to restart of unit from hibernation
- rise in pressure drop over heat exchanger compared to dry heat exchanger (if mounted)
- Tice temperature on heat exchanger exhaust side (if mounted)

De-icing steps - see table for procedure

De-icing step	Operating status
---	The unit is operating normally
---	Ice formation in heat exchanger - unit ready to start de-icing: The need for startup of de-icing is registered via temperature (T _{ice}) or measurement of pressure drop over the heat exchanger (DEP)
A	VEX340: Return air up to 30% VEX320-330/350-370/CX340-350/VEX310T-350T: Bypass outdoor air up to 100%
B	VEX340: Reduced extract air and supply air + 30% return air VEX320-330/350-370/CX340-350/VEX310T-350T: Reduced extract air and supply air + bypass outdoor air up to 100%.
C	Imbalance via reduced supply air
D	Imbalance via reduced supply air and increased extract air
E	Hibernation - unit stopped
F	Restart after hibernation finished - 5 minute test operation

Menu 2.5 - Pressure

2.5 Pressure	
External pressure:	
Supply air duct	0Pa
Extract air duct	0Pa
Filter pressure:	
Outdoor air filter	0Pa
Extract air filter	0Pa
CFH Exch.	0Pa
CCW exhaust	0Pa

The menu shows:

- external pressure in supply air and extract air duct (if MPT-DUCT installed)
- pressure drop over supply air and extract air filter (if MPTF is mounted)
- pressure drop over counterflow heat exchanger (if DEP is activated)
- pressure drop across CCW coil in exhaust duct

Menu 2.6 - Heating coil

NB:

The menu displays depend on whether a water heating coil or an electric heating coil is installed as a heating unit (see Menu 3.4 Accessories).

Water heating coil

2.6 Heating coil	
Water heating coil:	
Supply	25.0°C
Return	15.0°C
External return	15.0°C
Heat retention	0%
Pump	Off

The menu shows:

- Supply temperature
- Return temperature
- External return water temperature (coldest)
- Constant temperature - if the constant temperature function is active (specified as a percentage)
- Pump - if circulation pump in heating circuit is running

Electric heating coil

2.6 Heating coil	
Electric heating coil:	
Power step total	1
Active power steps	0
Setpoint	0.0%
TSA60/80	25.0°C

The menu shows:

- Number of heating coil power steps
- Number of active power steps
- Modulating step output
- Electric heating coil control box internal temperature

Menu 2.7 - CH cooling unit

2.7 Cooling/heat pump unit	
Comp. gas press. 0.00bar	
Suc. gas press.	0.00bar
Comp. gas press.	0.00°C
Feed temp.	0.00°C
Increased airflow	Nej
Balance	Ja
Reduction	0%
Block start	Ja
Press. drop rise	0%
CH Size	---

The menu shows:

- pressure gas pressure
- suction gas pressure
- pressure gas temperature
- supply temperature
- air volume
- balance
- reduction
- blocked start - if the cooling unit is blocked due to the 10-minute interval between starts
- pressure drop rise
- CH size

Menu 2.8 - CCW cold water coil

2.8 CCW	
Supply	25.0 °C
Pump	Off

The menu shows:

- Supply temperature for the cold water coil
 - Pump - whether circulation pump in cooling circuit is running
-

Menu 2.9 - CU cooling unit

2.9 CU cooling unit	
Comp gas temp.	0.0 °C
Comp gas pressure	0.0 bar
Evaporator temp.	0.0 °C
Reduction	0.0%
Blocked start	Aktive

The menu shows:

- pressure gas temperature
 - pressure gas pressure
 - Evaporation temperature
 - Reduction - any reduction to cooling output (due to excessive refrigerant pressure)
 - blocked start - if the cooling unit is blocked due to the 10-minute interval between starts
-

Menu 2.10 - MXCU external cooling unit

2.10 MXCU	
Cooling unit	Off
Performance	0.0%

The menu shows:

- If the cooling unit is operating
 - Current output of cooling unit
-

Menu 2.11 - External cooling/heating pump unit MXHP

2.11 MXHP	
MXHP Module	Off
Htg/cool status	Heating
Output	0.0%

The menu shows:

- whether the cold/heat pump module is operating
 - Status - whether the DX unit is cooling or heating
 - Actual output of the cooling/heat pump unit
-

Menu 2.12 - Hour counters (VEX340-350-360-370/CX340-350/VEX310T-350T)

2.11 Timers	
Supply air motor	1500hr
Extract air motor	1500hr

The menu shows hour meters for fan motors.

Menu 2.13 - CO2/RH sensors (if mounted)

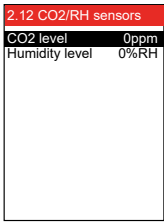

- The menu shows:
- CO₂ level
 - Humidity level (air humidity)

Menu 6 - Versions

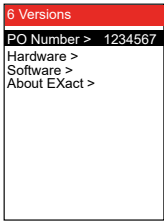

Menu 6.1 PO number

The menu shows the production order number for the VEX/CX unit.

Menu 6.2 Hardware

The menu shows the hardware version for each unit fitted.

Menu 6.3 Software

The menu shows the software version for each unit fitted.

Menu 6.4 About EX-act

The menu shows system information about the EXact control system.

Menu 8 - Service

Do not open



the service doors before the supply voltage has been disconnected at the isolation switch. The isolation switch is located on the connection box, see illustration.

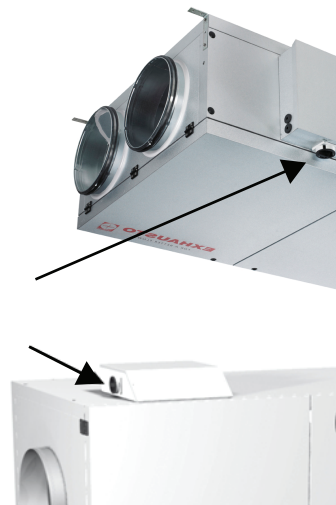
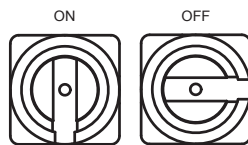

Weekly plan



It is important to set ventilation to OFF when the weekly plan is active:

Set ventilation to OFF	
<p>Note - If the HMI panel shows 0% (VEX/CX is inactive) and the unit is operating to a weekly plan when servicing begins, there is a risk that the program may be changed by timer operation and re-start the VEX unit.</p>	
<ul style="list-style-type: none"> • Log on to technician menu, using password 1111 • Change to manual operation via menu 1 • Change back to user menu • The icon for manual operation appears in the right-hand corner of the menu 	
<ul style="list-style-type: none"> • Press the ventilation icon • Set the ventilation to 0% using the arrows • Press approve 	
<ul style="list-style-type: none"> • OFF will now appear on the display next to the ventilation icon 	

BMS unit or Web server



If the VEX/CX is controlled via a BMS or Web server, these controls could override the OFF function and the VEX/CX may start up irregularly. To disconnect the BMS or WEB server connection, you must remove the plug from the EXact2 main board. Refer to the section on the terminal board in the Electrical Installation Guide.

Additional service HMI panel

If the HMI panel is located far from the VEX/CX, it is recommended that an auxiliary HMI panel be connected to the VEX/CX in the connection box.

**Example, Horizontal
VEX300**

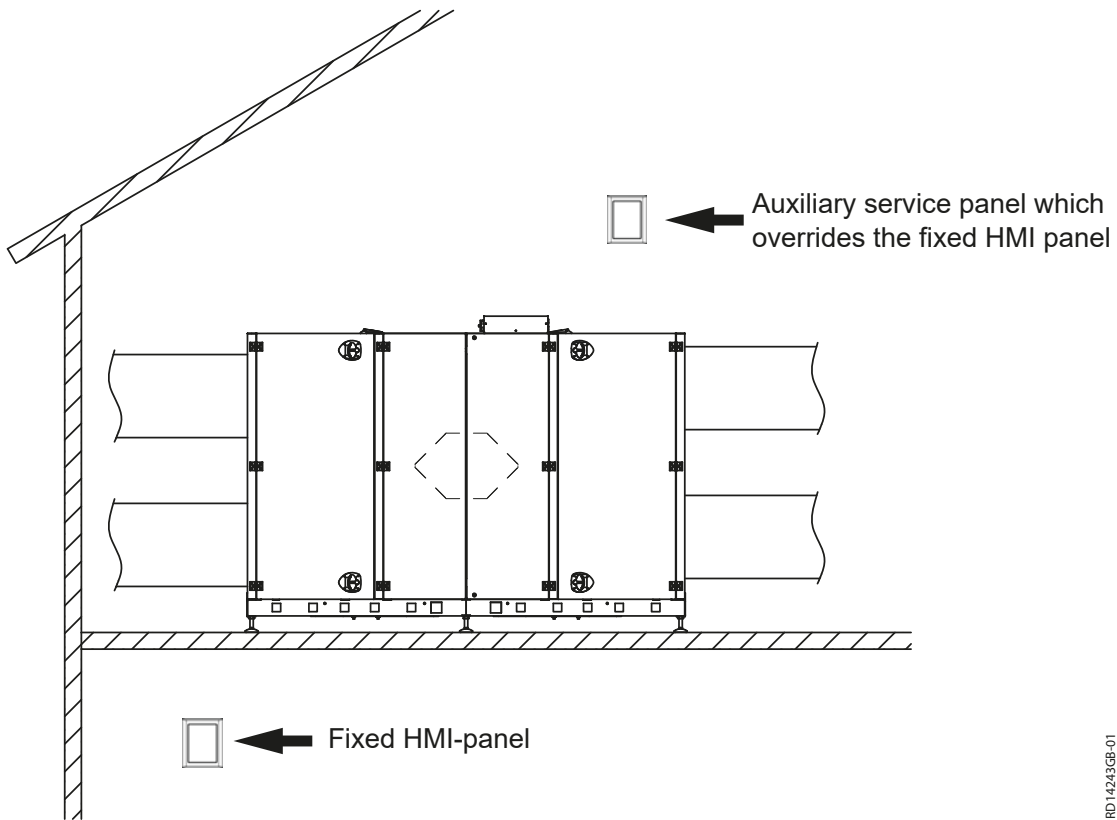

RD14243GB-01

Service panel connector - EXact2

Connector on EXact2 main board for auxiliary service panel

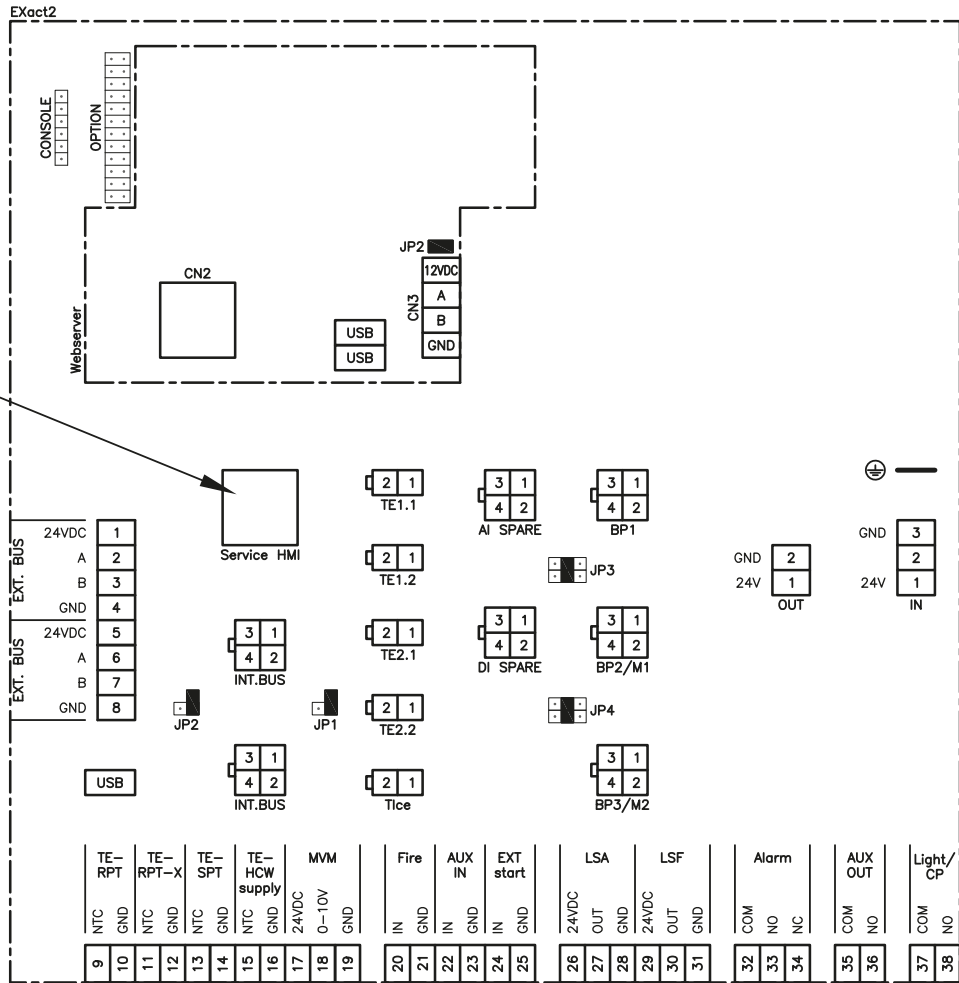

RD13093GB-01

Cable requirements

The service panel cable can be ordered from EXHAUSTO (product number: HMI2SERVICEC).

Menu 8.2 - VDI 6022

Key VDI 6022 is a German hygiene standard.

Menu

8.2 VDI 6022	
Light >	Off
Filter pressure:	
Extract air filter	0 Pa
Outdoor filter	0 Pa

Lighting

Switch light on/off (applies only to units ordered with lights. The light in the VEX switches off again when the menu is exited. Not possible in case of iHCW, as the output is used for the circulation pump (CP).

Filter monitor

Reading for filter pressure loss during operation.

Menu 8.3 - Forced start**Pre-conditions**

To use the forced start menu, the unit must be set to OFF in the user menu (Ventilation).

NB:

When Menu 8.3 "Forced start" is exited, forced start is reset and normal operation can be resumed. When a submenu is exited, the values in the submenu are reset.

Menu

8.3 Forced start	
Fans >	
Heating coil >	
Cooling unit	
Dampers and relays >	
EXEB relays	

Menu 8.3.1 Fans

8.3.1 Fans	
Supply air >	0%
Extract air >	0%
Error on MC1	No
Error on MC2	No

If there are no current faults for the fans ("Fault on MC1 and MC2" shown as "No"), forced start may be activated for the supply air and extract air fans.

Menu 8.3.2 Heating coil

8.3.2 Heating coil	
HCE	0%
Supply air	0%
Min. flow	0l/s
Measured flow	0l/s
Run on	No
Error on unit	No

For electric heating coil HCE:

If there are no current faults for the heating coil ("Fault on unit" shown as "No"), forced start may be activated:

- Start the supply air fan and increase its speed until the measured flow is greater than the min. flow
- Then start HCE

Note

To avoid the electric heating coil dropping out due to an overheating alarm when the electric heating coil is stopped:

- Do not exit the menu or stop the supply air fan until **Run-on is shown as "No"**.

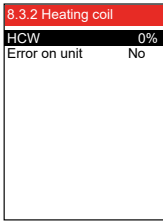

For water heating coil HCW:

If there are no current faults for the heating coil ("Fault on unit" shown as "No"), forced start may be activated:

- Enter an output level for HCW to start the motor valve and pump for the water heating coil

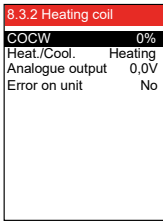

For water heating coil MCOCW

If there are no current faults for the heating coil ("Fault on unit" shown as "No"), forced start may be activated:

- Enter an output level for MCOCW to start the motor valve and pump for the water heating coil
- Select "Heating" for choice of heating or cooling state.

Menu 8.3.3 Cooling unit

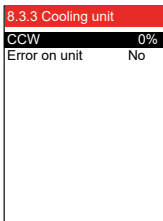

(The menu screen is different depending on which cooling unit is selected - CH, CCH, CCW, MXCU, MXHP)

If there are no current faults for the cooling unit ("Fault on unit" shown as "No"), forced start may be activated:

- Set the output level for the cooling unit

Menu 8.3.4 Dampers and relays

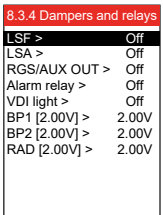

The following dampers may be forced open or closed via the menu:

- LSF (closing damper, outdoor air)
- LSA (closing damper, exhaust air)
- RGS/AUX OUT (flue gas damper)
- The alarm relay may be forced to trigger.
- The light in units fitted with VDI lights may be switched on and off
- BP1 (bypass damper 1)
- BP2 (bypass damper 2 - only VEX340-350-360-370)
- BP3 (bypass damper 3 - only VEX370)
- RAD (return air damper - only VEX340).

Menu 8.4 - Calibrating MPT

NB:

The pressure transducers (MPT) may only be calibrated when the unit is stopped. The doors should be opened to equalise pressure with the surroundings and to ensure correct calibration.

- Select "Yes" for calibration (automatically changes to "No" again when the MPTs have been calibrated).

8.4 Calibration of MPT	
MPT1, P1	---
MPT1, P2	---
MPT2, P1	---
MPT2, P2	---
MPT3, P1	---
MPT3, P2	---
MPT4, P1	---
MPT4, P2	---
MPT5, P1	---
MPT5, P2	---
MPT6, P1	---
MPT6, P2	---
MPT7, P1	---
MPT7, P2	---
Calibrate >	No

Last calibrated:
Dato xx-xx-xxxx
Tid xx:xx:xx

Select "Yes" for calibration (automatically changes to "No" again when the MPTs have been calibrated).

6. Alarms

6.1 Alarms and info (Menu 4)

Alarms shown in display



In the event of alarms/warnings on the system, one of the following icons is shown in the menu bar's right-hand corner in the user menu

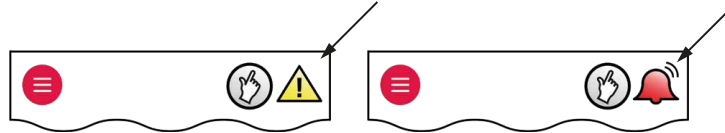

NB:

Alarms are shown in the event of unit faults or irregular operation

- In the event of a warning icon: Contact the service technician who can help reset the warning.
- In the event of an alarm icon: Press the icon and go directly to menu 4 "Alarm and info".
- Check menu "4.5 Current list" for alarm message and use the alarm list at the end of this manual if necessary.

Alarm list Menu 4.5

Main menu	4 Alarm and info	4.5 Current list
Operating mode >	Alarm Yes	Alarm 01 01144
Operating readings >	Warning No	2009-02-10 10:54:17
Settings >	Information No	Alarm 02 02144
Alarm and info >	Reset alarms > No	2009-02-10 11:01:12
Time and weekly plan >	Current list >	Alarm 03 03073
Versions >	Alarm log list >	2009-02-10 18:22:50
Safety functions >	Delete alarm log > No	Alarm 04 12012
Service >		2009-02-10 18:25:00
Save settings >		Alarm 05 13071
		2009-02-10 19:00:00

The active alarms can be seen in the current alarms list in Menu 4.5.

6.2 Reset alarms

Alarm causes must be found

An alarm can be reset once the cause has been remedied.

Menu 4

All alarms may be reset by selecting reset alarms in Menu 4

More than one alarm

If several alarms are active, they will all be reset simultaneously.

Alarms trigger again

If an alarm repeatedly triggers, contact a service technician.

6.3 Alarm display and Current list – cause of error

Current list

4.5 Current list	
Alarm 01	01144
2009-02-10	10:54:17
Alarm 02	02144
2009-02-10	11:01:12
Alarm 03	03073
2009-02-10	18:22:50
Alarm 04	12012
2009-02-10	18:25:00
Alarm 05	13071
2009-02-10	19:00:00

Alarm code

If an alarm has been generated, an alarm code is shown in the display in the format **XXYYZ**, where .
 XX = unit
 YY = fault code
 Z = category of alarm. See category table in this section.

16 alarms

There can be up to 16 alarms on the "Current list". The first alarm to be added to the queue will be the first alarm to be removed, if there are more than 16 alarms (FIFO principle).

Info in EXact

shown only in the alarm log list Menu 4.6

Example - list of alarms

36024 is an alarm on EC controller 1 (**36024**). The alarm description is *"The supply voltage to the EC controller is too low"* (**36024**). The category is critical (**36024**).



Any active alarm is shown under the alarm symbol. If there is more than one alarm, each individual alarm is shown for two seconds on a rotation basis.

Category

Category (Z)	Alarm level	Effect on operation	Icon
1	Info	Operation continues	
2	Warning	Operation continues	
3	Alarm	Operation continues but with reduced functionality	
4	Critical	Operation stops	
5	Fire	Triggered fire alarm procedure mode starts	

Find troubleshooting directions in the list of alarms via the alarm number.

Alarm log list - Menu 4.6

Note: It takes 19 seconds for the list to appear.

A letter is shown following the alarm or info code:

C = Clear

S = Set

The alarm log list shows the latest 100 alarms, warnings and past information.

The first alarm/info to be added to the queue will be the first to be removed, if there are more than 100 of them (FIFO principle).

Delete alarm log The alarm log can be deleted by selecting "Yes". This action cannot be reversed.

6.4 List of alarms

Main Control VEX/CX				
Unit	Fault code	Category	Alarm description	Troubleshooting (See appendix 1: "Simplified diagrams" for the location of dampers, sensors, air directions, etc.)
xx	yy	z		
00	01	1	Control is powered	Indicates when control is powered
00	02	1	Unknown reboot of control	<ul style="list-style-type: none"> Unknown fault, call service
00	03	1	A watchdog rebooted control	<ul style="list-style-type: none"> Unknown fault, call service
00	04	1	Software rebooted control	The software has rebooted the control system.
00	05	1	User rebooted control	The user has rebooted the control system.
00	06	1	Power supply voltage drop rebooted the control system	Reboot of control due to voltage drop
00	07	1	Time changed	Display showing when the time setting was changed.
00	16	1	"Manual" alarms reset by user	The user has reset the alarms

Frequency converter 1				
Unit	Fault code	Category	Alarm description	Troubleshooting (See appendix 1: "Simplified diagrams" for the location of dampers, sensors, air directions, etc.)
xx	yy	z		
01	01	4	One or more phases between frequency converter and motor is/are short-circuited to earth	<ul style="list-style-type: none"> Check the cable between frequency converter 1 and motor
01	02	4	Max. motor current from frequency converter exceeds limit by 300%	<ul style="list-style-type: none"> Check for low voltage to frequency converter 1
01	03	4	Frequency converter DC circuit max. voltage exceeds limit	<ul style="list-style-type: none"> Check for overvoltage to frequency converter 1
01	04	2	Frequency converter DC circuit voltage too low when motor(s) start(s)	<ul style="list-style-type: none"> Check for low voltage to frequency converter 1
01	05	4	Frequency converter DC circuit voltage too low when VEX/CX unit stops	<ul style="list-style-type: none"> Check for low voltage to frequency converter 1
01	06	4	Frequency converter power supply has lost a phase	<ul style="list-style-type: none"> Check wiring from the power supply connection to the isolation switch in the VEX/CX unit Check cable connections from the isolation switch to frequency converter 1
01	07	4	Frequency converter power supply to motor(s) has lost a phase	<ul style="list-style-type: none"> Check the cable between frequency converter 1 and motor Check for a short circuit in the motor windings
01	08	4	Frequency converter overheated (based on internal calculations)	<ul style="list-style-type: none"> Check if the temperature at frequency converter 1 exceeded the permitted 35°C when the alarm was tripped. If the temperature has been too high, the unit will restart when the air temperature falls below 35°C.
01	09	2	Frequency converter cooling coil overheating	<ul style="list-style-type: none"> Check if the temperature at frequency converter 1 is close to the permitted 35°C. Check whether there is free passage for cooling air between the cooling fins in the frequency converter.
01	10	4	Frequency converter cooling coil overheated	<ul style="list-style-type: none"> Check if the temperature at frequency converter 1 exceeded the permitted 35°C when the alarm was tripped. If the temperature has been too high, the unit will restart when the air temperature falls below 35°C.
01	11	4	Frequency converter motor(s) drawing too much current	Fault on frequency converter 1
01	14	4	No modbus communication to frequency converter	<ul style="list-style-type: none"> Check the cable between the connection board and frequency converter 1

Frequency converter 1				
Unit	Fault code	Category	Alarm description	Troubleshooting (See appendix 1: "Simplified diagrams" for the location of dampers, sensors, air directions, etc.)
xx	yy	z		
01	15	4	Frequency converter hardware fault	Fault on frequency converter 1
01	16	4	Frequency converter software version out of date	<ul style="list-style-type: none"> Upgrade software in frequency converter 1

Frequency converter 1				
Unit	Fault code	Category	Alarm description	Troubleshooting (See appendix 1: "Simplified diagrams" for the location of dampers, sensors, air directions, etc.)
xx	yy	z		
02	01	4	One or more phases between frequency converter and motor is/are short-circuited to earth	<ul style="list-style-type: none"> Check the cable between frequency converter 2 and motor
02	02	4	Max. motor current from frequency converter exceeds limit by 300%	<ul style="list-style-type: none"> Check for low voltage to frequency converter 2
02	03	4	Frequency converter DC circuit max. voltage exceeds limit	<ul style="list-style-type: none"> Check for overvoltage to frequency converter 2
02	04	2	Frequency converter DC circuit voltage too low when motor(s) start(s)	<ul style="list-style-type: none"> Check for low voltage to frequency converter 2
02	05	4	Frequency converter DC circuit voltage too low when VEX/CX unit stops	<ul style="list-style-type: none"> Check for low voltage to frequency converter 2
02	06	4	Frequency converter power supply has lost a phase	<ul style="list-style-type: none"> Check wiring from the power supply connection to the isolation switch in the VEX/CX unit Check cable connections from the isolation switch to frequency converter 2
02	07	4	Frequency converter power supply to motor(s) has lost a phase	<ul style="list-style-type: none"> Check the cable between frequency converter 2 and motor Check for a short circuit in the motor windings
02	08	4	Frequency converter overheated (based on internal calculations)	<ul style="list-style-type: none"> Check if the temperature at frequency converter 2 exceeded the permitted 35°C when the alarm was tripped. If the temperature has been too high, the unit will restart when the air temperature falls below 35°C.
02	09	2	Frequency converter cooling coil overheating	<ul style="list-style-type: none"> Check if the temperature at frequency converter 1 is close to the permitted 35°C. Check whether there is free passage for cooling air between the cooling fins in the frequency converter.
02	10	4	Frequency converter cooling coil overheated	<ul style="list-style-type: none"> Check if the temperature at frequency converter 2 exceeded the permitted 35°C when the alarm was tripped. If the temperature has been too high, the unit will restart when the air temperature falls below 35°C.
02	11	4	Frequency converter motor(s) drawing too much current	Fault on frequency converter 2.
02	14	4	No modbus communication to frequency converter	<ul style="list-style-type: none"> Check the cable between the connection board and frequency converter 2.

Frequency converter 1				
Unit	Fault code	Category	Alarm description	Troubleshooting (See appendix 1: "Simplified diagrams" for the location of dampers, sensors, air directions, etc.)
xx	yy	z		
02	15	4	Frequency converter hardware fault	Fault on frequency converter 2.
02	16	4	Frequency converter software version out of date	<ul style="list-style-type: none"> Upgrade software in frequency converter 2.

Pressure transmitter 1				
Unit	Fault code	Category	Alarm description	Troubleshooting (See appendix 1: "Simplified diagrams" for the location of dampers, sensors, air directions, etc.)
xx	yy	z		
04	01	4	No modbus communication to pressure transmitter	<ul style="list-style-type: none"> Check the modbus cable between the connection board (EXact)/main board (EXact2) and MPT1. Check modbus cable for faults from MPT1 to the other units
04	02	4	Calibration fault	<ul style="list-style-type: none"> Re-calibrate If the problem continues, MPT1 must be replaced
04	03	1	Calibrate pressure transmitter	Calibrate MPT1
04	04	1	Pressure transmitter using old calibration values	<p>When the unit starts up this information is displayed. It does not necessarily mean that the pressure transmitter has to be calibrated.</p> <ul style="list-style-type: none"> Check if the MPT is out of calibration in menu 8.4 and recalibrate if required
04	05	4	Pressure transmitter not calibrated	<ul style="list-style-type: none"> Set the VEX/CX to "OFF" in the user menu and open the doors. Next calibrate the MPT in menu 8.4.

Pressure transmitter 2				
Unit	Fault code	Category	Alarm description	Troubleshooting (See appendix 1: "Simplified diagrams" for the location of dampers, sensors, air directions, etc.)
xx	yy	z		
05	01	4	No modbus communication to pressure transmitter	<ul style="list-style-type: none"> Check the modbus cable between the connection board (EXact)/main board (EXact2) and MPT2. Check modbus cable for faults from MPT2 to the other units
05	02	4	Calibration fault	<ul style="list-style-type: none"> Re-calibrate If the problem continues, MPT2 must be replaced
05	03	1	Calibrate pressure transmitter	Calibrate MPT2
05	04	1	Pressure transmitter using old calibration values	<p>When the unit starts up this information is displayed. It does not necessarily mean that the pressure transmitter has to be calibrated.</p> <ul style="list-style-type: none"> Check if the MPT is out of calibration in menu 8.4 and recalibrate if required
05	05	4	Pressure transmitter not calibrated	<ul style="list-style-type: none"> Set the VEX/CX to "OFF" in the user menu and open the doors. Next calibrate the MPT in menu 8.4.

Pressure transmitter 3				
Unit	Fault code	Category	Alarm description	Troubleshooting (See appendix 1: "Simplified diagrams" for the location of dampers, sensors, air directions, etc.)
xx	yy	z		
06	01	4	No modbus communication to pressure transmitter	<ul style="list-style-type: none"> Check the modbus cable between the connection board (EXact)/main board (EXact2) and MPT3. Check modbus cable for faults from MPT3 to the other units
06	02	4	Calibration fault	<ul style="list-style-type: none"> Re-calibrate If the problem continues, MPT3 must be replaced
06	03	1	Calibrate pressure transmitter	Calibrate MPT3
06	04	1	Pressure transmitter using old calibration values	<p>When the unit starts up this information is displayed. It does not necessarily mean that the pressure transmitter has to be calibrated.</p> <ul style="list-style-type: none"> Check if the MPT is out of calibration in menu 8.4 and recalibrate if required
06	05	4	Pressure transmitter not calibrated	<ul style="list-style-type: none"> Set the VEX/CX to "OFF" in the user menu and open the doors. Next calibrate the MPT in menu 8.4.

Pressure transmitter 5				
Unit	Fault code	Category	Alarm description	Troubleshooting (See appendix 1: "Simplified diagrams" for the location of dampers, sensors, air directions, etc.)
xx	yy	z		
08	01	4	No modbus communication to pressure transmitter	<ul style="list-style-type: none"> • Check the modbus cable between the connection board (EXact)/main board (EXact2) and MPT5. • Check modbus cable for faults from MPT5 to the other units
08	02	4	Calibration fault	<ul style="list-style-type: none"> • Re-calibrate • If the problem continues, MPT5 must be replaced
08	03	1	Calibrate pressure transmitter	Calibrate MPT5
08	04	1	Pressure transmitter using old calibration values	<p>When the unit starts up this information is displayed. It does not necessarily mean that the pressure transmitter has to be calibrated.</p> <ul style="list-style-type: none"> • Check if the MPT is out of calibration in menu 8.4 and recalibrate if required
08	05	4	Pressure transmitter not calibrated	<ul style="list-style-type: none"> • Set the VEX/CX to "OFF" in the user menu and open the doors. Next calibrate the MPT in menu 8.4.

Pressure transmitter 6				
Unit	Fault code	Category	Alarm description	Troubleshooting (See appendix 1: "Simplified diagrams" for the location of dampers, sensors, air directions, etc.)
xx	yy	z		
09	01	4	No modbus communication to pressure transmitter	<ul style="list-style-type: none"> • Check the modbus cable between the connection board (EXact)/main board (EXact2) and MPT6. • Check modbus cable for faults from MPT6 to the other units
09	02	4	Calibration fault	<ul style="list-style-type: none"> • Re-calibrate • If the problem continues, MPT6 must be replaced
09	03	1	Calibrate pressure transmitter	Calibrate MPT6
09	04	1	Pressure transmitter using old calibration values	<p>When the unit starts up this information is displayed. It does not necessarily mean that the pressure transmitter has to be calibrated.</p> <ul style="list-style-type: none"> • Check if the MPT is out of calibration in menu 8.4 and recalibrate if required
09	05	4	Pressure transmitter not calibrated	<ul style="list-style-type: none"> • Set the VEX/CX to "OFF" in the user menu and open the doors. Next calibrate the MPT in menu 8.4.

Temperature sensor				
Unit	Fault code	Category	Alarm description	Troubleshooting (See appendix 1: "Simplified diagrams" for the location of dampers, sensors, air directions, etc.)
xx	yy	z		
11	01	4	TE11: Extract air duct temperature sensor disconnected	TE11: <ul style="list-style-type: none"> • Check the sensor's resistance complies with the actual temperature. See temperature resistance table appendix 2. • If the sensor resistance has significantly changed in value, it should be replaced.
11	02	4	TE11: Extract air duct temperature sensor short-circuited	TE11: <ul style="list-style-type: none"> • Check the sensor's resistance complies with the actual temperature. See temperature resistance table appendix 2. • If the sensor resistance has significantly changed in value, it should be replaced.
11	03	3	TE12: Exhaust air duct temperature sensor disconnected	TE12: <ul style="list-style-type: none"> • Check the sensor's resistance complies with the actual temperature. See temperature resistance table appendix 2. • If the sensor resistance has significantly changed in value, it should be replaced.
11	04	3	TE12: Exhaust air duct temperature sensor short-circuited	TE12: <ul style="list-style-type: none"> • Check the sensor's resistance complies with the actual temperature. See temperature resistance table appendix 2. • If the sensor resistance has significantly changed in value, it should be replaced.
11	05	4	TE21: Outdoor air duct temperature sensor disconnected	TE21: <ul style="list-style-type: none"> • Check the sensor's resistance complies with the actual temperature. See temperature resistance table appendix 2. • If the sensor resistance has significantly changed in value, it should be replaced.
11	06	4	TE21: Outdoor air duct temperature sensor short-circuited	TE21: <ul style="list-style-type: none"> • Check the sensor's resistance complies with the actual temperature. See temperature resistance table appendix 2. • If the sensor resistance has significantly changed in value, it should be replaced.
11	07	4	TE22: Supply air duct temperature sensor disconnected	TE22: <ul style="list-style-type: none"> • Check the sensor's resistance complies with the actual temperature. See temperature resistance table appendix 2. • If the sensor resistance has significantly changed in value, it should be replaced.
11	08	4	TE22: Supply air duct temperature sensor short-circuited	TE22: <ul style="list-style-type: none"> • Check the sensor's resistance complies with the actual temperature. See temperature resistance table appendix 2. • If the sensor resistance has significantly changed in value, it should be replaced.
11	09	4	TE-RPT: Return water pipe temperature sensor on water heating coil disconnected	TE-RPT: <ul style="list-style-type: none"> • Check the sensor's resistance complies with the actual temperature. See temperature resistance table appendix 2. • If the sensor resistance has significantly changed in value, it should be replaced.

Temperature sensor						
Unit	Fault code	Category	Alarm description	Troubleshooting (See appendix 1: "Simplified diagrams" for the location of dampers, sensors, air directions, etc.)		
xx	yy	z				
11	10	4	TE-RPT: Return water pipe temperature sensor on water heating coil short-circuited	TE-RPT: <ul style="list-style-type: none"> Check the sensor's resistance complies with the actual temperature. See temperature resistance table appendix 2. If the sensor resistance has significantly changed in value, it should be replaced. 		
11	11	4	TE-SPT: Supply water pipe temperature sensor on water cooling coil disconnected	TE-SPT: <ul style="list-style-type: none"> Check the sensor's resistance complies with the actual temperature. See temperature resistance table appendix 2. If the sensor resistance has significantly changed in value, it should be replaced. 		
11	12	4	TE-SPT: Supply water pipe temperature sensor on water cooling coil short-circuited	TE-SPT: <ul style="list-style-type: none"> Check the sensor's resistance complies with the actual temperature. See temperature resistance table appendix 2. If the sensor resistance has significantly changed in value, it should be replaced. 		
11	13	4	TE-RPT-X: External temperature sensor on return water pipe from water heating coil has been disconnected	TE-RPT-X: <ul style="list-style-type: none"> Check the sensor's resistance complies with the actual temperature. See temperature resistance table appendix 2. If the sensor resistance has significantly changed in value, it should be replaced. 		
11	14	4	TE-RPT-X: External temperature sensor on return water pipe from water heating coil has short-circuited	TE-RPT-X: <ul style="list-style-type: none"> Check the sensor's resistance complies with the actual temperature. See temperature resistance table appendix 2. If the sensor resistance has significantly changed in value, it should be replaced. 		
11	15	4	Tice Supply water pipe temperature sensor on water cooling coil disconnected	Tice <ul style="list-style-type: none"> Check the sensor's resistance complies with the actual temperature. See temperature resistance table appendix 2. If the sensor resistance has significantly changed in value, it should be replaced. 		
11	16	4	Tice Supply water pipe temperature sensor on water cooling coil short-circuited	Tice <ul style="list-style-type: none"> Check the sensor's resistance complies with the actual temperature. See temperature resistance table appendix 2. If the sensor resistance has significantly changed in value, it should be replaced. 		

Fire thermostats				
Unit	Fault code	Category	Alarm description	Troubleshooting (See appendix 1: "Simplified diagrams" for the location of dampers, sensors, air directions, etc.)
xx	yy	z		
12	01	5	BT40/50, FIRE: Triggered fire alarm has stopped VEX/CX unit	BT40/50, FIRE: In event of Fire: Follow the building emergency procedure Fire thermostat triggered when there is no fire: <ul style="list-style-type: none"> • The closed circuit is broken. Find out why the fire detection unit has broken the circuit. • If no unit is connected – check jumper.
12	02	5	BT70, AUX IN: Triggered fire alarm has stopped VEX/CX unit	BT70, AUX IN: In event of Fire: Follow the building emergency procedure Fire thermostat triggered when there is no fire: <ul style="list-style-type: none"> • The closed circuit is broken. Find out why the fire detection unit has broken the circuit. • If no unit is connected – check jumper.
12	03	3	Fire brigade override error	The fire brigade override panel has been left in an illegal setting.

Filters				
Unit	Fault code	Category	Alarm description	Troubleshooting (See appendix 1: "Simplified diagrams" for the location of dampers, sensors, air directions, etc.)
xx	yy	z		
13	01	2	Replace extract air filter soon	Replace extract air filter soon
13	02	3	Replace extract air filter!	Replace extract air filter!
13	03	2	Replace outdoor air filter soon	Replace outdoor air filter soon
13	04	3	Replace outdoor air filter soon	Replace outdoor air filter soon

HC Alarm				
Unit	Fault code	Category	Alarm description	Troubleshooting (See appendix 1: "Simplified diagrams" for the location of dampers, sensors, air directions, etc.)
xx	yy	z		
14	01	1	Thermal fuse TSA70 activated	HCE: Info is reset when the temperature falls below 70 °C
14	02	2	Thermal fuse TSA70 is/has been activated	HCE: <ul style="list-style-type: none"> • Check airflow across the electric heating coil, select same fan speed as when the alarm was triggered <p>There must be the following min. airflows across the electric heating coil, in order to release min. 50% heating output:</p> <ul style="list-style-type: none"> - VEX320 with HCE: 28 l/s (100 m³/h) - VEX330 with HCE: 28 l/s (100 m³/h) - VEX340 with HCE: 80 l/s (288 m³/h) - VEX350 with HCE: 200 l/s (720 m³/h) - VEX360 with HCE: 200 l/s (720 m³/h) - VEX370 with HCE: 360 l/s (1296 m³/h) - CX340 with HCE: 93 l/s (335 m³/h) - CX350 with HCE: 120l/s (432 m³/h) - VEX310T with HCE: 21 l/s (75 m³/h) - VEX320T with HCE: 38 l/s (138 m³/h) - VEX330T with HCE: 85 l/s (304 m³/h) - VEX340T with HCE: 127 l/s (457 m³/h) - VEX350T with HCE: 165 l/s (394 m³/h)
14	03	1	Thermal fuse TSA90/120 activated.	HCE: Info is reset when the temperature falls below 90°C or 120°C respectively.

HC Alarm				
Unit	Fault code	Category	Alarm description	Troubleshooting (See appendix 1: "Simplified diagrams" for the location of dampers, sensors, air directions, etc.)
xx	yy	z		
14	04	4	Thermal fuse TSA90/120 is/has been activated	<p>HCE:</p> <ul style="list-style-type: none"> • Check airflow across the electric heating coil, select same fan speed as when the alarm was triggered <p>There must be the following min. airflows across the electric heating coil, in order to release min. 50% heating output:</p> <ul style="list-style-type: none"> - VEX320 with HCE: 28 l/s (100 m³/h) - VEX330 with HCE: 28 l/s (100 m³/h) - VEX340 with HCE: 80 l/s (288 m³/h) - VEX350 with HCE: 200 l/s (720 m³/h) - VEX360 with HCE: 200 l/s (720 m³/h) - VEX370 with HCE: 360 l/s (1296 m³/h) - CX340 with HCE: 93 l/s (335 m³/h) - CX350 with HCE: 120 l/s (432 m³/h) - VEX310T with HCE: 21 l/s (75 m³/h) - VEX320T with HCE: 38 l/s (138 m³/h) - VEX330T with HCE: 85 l/s (304 m³/h) - VEX340T with HCE: 127 l/s (457 m³/h) - VEX350T with HCE: 165 l/s (394 m³/h) <p>Note for HCE: The electric heating coil must be manually reset before the alarm can be reset in the control panel.</p>
14	05	1	Internal alarm on electrical heating coil control has been activated.	<p>HCE:</p> <p>Internal error in control box situated next to the electric heating coil. The error may be due to excessive temperature, lacking phase or a hardware error in the control box.</p> <ul style="list-style-type: none"> • Check the connection and the cooling conditions • Then try switching the isolation switch off and on. <p>The information is automatically reset once the error has been remedied.</p>
14	06	2	Internal alarm on electrical heating coil control has been activated.	<p>HCE:</p> <p>Internal error in control box situated next to the electric heating coil. The error may be due to excessive temperature, lacking phase or a hardware error in the control box.</p> <ul style="list-style-type: none"> • Check the connection and the cooling conditions • Then try switching the isolation switch off and on. <p>The warning is automatically reset once the error has been remedied.</p>
14	07	1	Electrical heating coil internal thermal fuse activated.	<p>HCE:</p> <p>Info is reset when the temperature falls below 60°C in the control system box.</p>
14	08	4	Electrical heating coil control's internal thermal fuse is/has been activated.	<p>HCE:</p> <ul style="list-style-type: none"> • Temperature in the electric heating coil control box is/has been over 60°C (VEX320-330)/80°C (VEX340-350-360/CX340-50/VEX310T-350T). Check what might be the cause of the high temperature and correct the fault.

HC Alarm				
Unit	Fault code	Category	Alarm description	Troubleshooting (See appendix 1: "Simplified diagrams" for the location of dampers, sensors, air directions, etc.)
xx	yy	z		
14	09	3	Return water temp. becoming too low. VEX/CX running in reduced mode and with frost protection.	<p>HCW:</p> <ul style="list-style-type: none"> Check that the hot water supply to the heating coil is functioning. <p>If the hot water supply is functioning, check if the motor valve opens and the circulation pump is running.</p> <ul style="list-style-type: none"> Check by turning the unit to "OFF" in the user menu and force start the motor valve and circulation pump in specialist menu 8.3. <p>The alarm resets automatically when the temperature rises above the heat retention level.</p>
14	10	3	Return water temp. too low. Frost protection activated. VEX/CX temporarily stopped.	<p>HCW:</p> <ul style="list-style-type: none"> Check that the hot water supply to the heating coil is functioning. <p>If the hot water supply is functioning, check if the motor valve opens and the circulation pump is running.</p> <ul style="list-style-type: none"> Check by turning the unit to "OFF" in the user menu and force start the motor valve and circulation pump in specialist menu 8.3. <p>The alarm resets automatically when the temperature rises above the heat retention level.</p>
14	11	3	Return water temp. measured by external sensor becoming too low. VEX/CX running in reduced mode.	<p>HCW:</p> <ul style="list-style-type: none"> Check that the hot water supply to the heating coil is functioning. <p>If the hot water supply is functioning, check if the motor valve opens and the circulation pump is running.</p> <ul style="list-style-type: none"> Check by turning the unit to "OFF" in the user menu and force start the motor valve and circulation pump in specialist menu 8.3. <p>The alarm resets automatically when the temperature rises above the heat retention level.</p>
14	12	3	Return water temp. measured by external sensor becoming too low. VEX/CX temporarily stopped.	<p>HCW:</p> <ul style="list-style-type: none"> Check that the hot water supply to the heating coil is functioning. <p>If the hot water supply is functioning, check if the motor valve opens and the circulation pump is running.</p> <ul style="list-style-type: none"> Check by turning the unit to "OFF" in the user menu and force start the motor valve and circulation pump in specialist menu 8.3. <p>The alarm resets automatically when the temperature rises above the heat retention level.</p>

HC Alarm				
Unit	Fault code	Category	Alarm description	Troubleshooting (See appendix 1: "Simplified diagrams" for the location of dampers, sensors, air directions, etc.)
xx	yy	z		
14	13	4	Max. total no. of re-starts within one hour reached.	<p>HCW:</p> <ul style="list-style-type: none"> Check that the hot water supply to the heating coil is functioning. <p>If the hot water supply is functioning, check if the motor valve opens and the circulation pump is running.</p> <ul style="list-style-type: none"> Check by turning the unit to "OFF" in the user menu and force start the motor valve and circulation pump in specialist menu 8.3. <p>The alarm resets automatically when the temperature rises above the heat retention level.</p>
14	14	4	Could not increase return water temp. within five minutes after frost protection with VEX/CX stopped.	<p>HCW:</p> <ul style="list-style-type: none"> Check that the hot water supply to the heating coil is functioning. <p>If the hot water supply is functioning, check if the motor valve opens and the circulation pump is running.</p> <ul style="list-style-type: none"> Check by turning the unit to "OFF" in the user menu and force start the motor valve and circulation pump in specialist menu 8.3. <p>The alarm resets automatically when the temperature rises above the heat retention level.</p>
14	16	3	Heating required but flow through electrical heating coil too low.	<p>HCE:</p> <p>There must be the following min. airflows across the electric heating coil, in order to release min. 50% heating output:</p> <ul style="list-style-type: none"> - VEX320 with HCE: 28 l/s (100 m³/h) - VEX330 with HCE: 28 l/s (100 m³/h) - VEX340 with HCE: 80 l/s (288 m³/h) - VEX350 with HCE: 200 l/s (720 m³/h) - VEX360 with HCE: 200 l/s (720 m³/h) - VEX370 with HCE: 360 l/s (1296 m³/h) - CX340 with HCE: 93 l/s (335 m³/h) - CX350 with HCE: 120 l/s (432 m³/h) - VEX310T with HCE: 21 l/s (75 m³/h) - VEX320T with HCE: 38 l/s (138 m³/h) - VEX330T with HCE: 85 l/s (304 m³/h) - VEX340T with HCE: 127 l/s (457 m³/h) - VEX350T with HCE: 165 l/s (394 m³/h)

HC Sensor				
Unit	Fault code	Category	Alarm description	Troubleshooting (See appendix 1: "Simplified diagrams" for the location of dampers, sensors, air directions, etc.)
xx	yy	z		
15	01	4	Supply air duct temperature sensor disconnected	<ul style="list-style-type: none"> Check the sensor's resistance complies with the actual temperature. See temperature resistance table appendix 2. If the sensor resistance has significantly changed in value, it should be replaced.
15	02	4	Supply air duct temperature sensor short-circuited	<ul style="list-style-type: none"> Check the sensor's resistance complies with the actual temperature. See temperature resistance table appendix 2. If the sensor resistance has significantly changed in value, it should be replaced.
15	05	4	Supply water pipe temperature sensor on water cooling coil disconnected	<ul style="list-style-type: none"> Check the sensor's resistance complies with the actual temperature. See temperature resistance table appendix 2. If the sensor resistance has significantly changed in value, it should be replaced.
15	06	4	Supply water pipe temperature sensor on water cooling coil short-circuited	<ul style="list-style-type: none"> Check the sensor's resistance complies with the actual temperature. See temperature resistance table appendix 2. If the sensor resistance has significantly changed in value, it should be replaced.
15	07	4	Return water pipe temperature sensor on water heating coil disconnected	<ul style="list-style-type: none"> Check the sensor's resistance complies with the actual temperature. See temperature resistance table appendix 2. If the sensor resistance has significantly changed in value, it should be replaced.
15	08	4	Return water pipe temperature sensor on water heating coil short-circuited	<ul style="list-style-type: none"> Check the sensor's resistance complies with the actual temperature. See temperature resistance table appendix 2. If the sensor resistance has significantly changed in value, it should be replaced.
15	09	4	Return water pipe external temperature sensor on water heating coil disconnected	<ul style="list-style-type: none"> Check the sensor's resistance complies with the actual temperature. See temperature resistance table appendix 2. If the sensor resistance has significantly changed in value, it should be replaced.
15	10	4	Return water pipe external temperature sensor on water heating coil is short-circuited	<ul style="list-style-type: none"> Check the sensor's resistance complies with the actual temperature. See temperature resistance table appendix 2. If the sensor resistance has significantly changed in value, it should be replaced.
15	13	4	Heat control internal temperature sensor disconnected	<ul style="list-style-type: none"> Replace the heat control circuit board MHCW
15	14	4	Heat control internal temperature sensor short-circuited	<ul style="list-style-type: none"> Replace the heat control circuit board MHCW
15	15	3	No modbus communication to pressure transmitter	<ul style="list-style-type: none"> Check modbus cable between heat control circuit board and subsequent MPT

HC Controller				
Unit	Fault code	Category	Alarm description	Troubleshooting (See appendix 1: "Simplified diagrams" for the location of dampers, sensors, air directions, etc.)
xx	yy	z		
16	01	1	MHCW: Module configured incorrectly. Check CN6 on circuit board.	Check the jumper in the CN6 connector on the heat control circuit board MHCW: -There must be a jumper across 7 and 8. MHCE: - a jumper must not be fitted.
16	02	1	HCW: Fan speed temporarily reduced	HCW: Fan speed temporarily reduced because warning limit for frost protection of water heating coil has been reached.
16	03	1	HCW: VEX/CX stop temporarily	HCW: Fan speed temporarily reduced because stop temperature for frost protection of water heating coil has been reached.
16	04	1	HCW: VEX/CX stop.	HCW: Fan speed stopped because of frost alarm on the water heating coil.
16	05	1	HCE: Run-on operating because electric heating coil warm in last three minutes.	HCE: The fans run on for three minutes after the electric heating coil has been in operation.
16	06	1	HC: Heat control currently run locally due to service	HC: Heat control temporarily controlled by Lodam Multi Tool. Override lasts for max. 60 minutes.
16	07	1	HC: Heat control safety functions overridden locally due to service	HC: Heat control temporarily controlled by Lodam Multi Tool. Override lasts for max. 60 minutes.
16	10	1	HCE: Heat output reduced due to low airflow in supply air duct	HCE: When the airflow is between 0.5 and 1.5 m/s over the electric heating elements, full heat output is not permitted. Full heat output is permitted only when airflow is more than 1.5 m/s over the heating elements.
16	13	4	HC: Heat control detected which was not selected in VEX/CX configuration	HC: The heating coil is configured in menu 3.4 "Accessories".
16	14	4	MHC: Heat control configured incorrectly in connection with selected VEX/CX configuration	Check the jumper in the CN6 connector on the heat control circuit board MHCW: -There must be a jumper across 7 and 8. MHCE: - a jumper must not be fitted.
16	15	4	MHCW: No modbus communication to water heat control	MHCW: <ul style="list-style-type: none"> • Check the modbus cable between the connection board (EXact)/main board (EXact2) and MHCW. • Check modbus cable for faults from HCW to the other units.
16	16	3	MHCE: No modbus communication to electrical heating control	MHCE: <ul style="list-style-type: none"> • Check the modbus cable between the connection board (EXact)/main board (EXact2) and MHCE. • Check modbus cable for faults from HCE to the other units

Airflow/pressure				
Unit	Fault code	Category	Alarm description	Troubleshooting (See appendix 1: "Simplified diagrams" for the location of dampers, sensors, air directions, etc.)
xx	yy	z		
20	01	1	Airflow/pressure in extract air duct airflow too high	The unit provides airflow that is 25% above the setpoint. <ul style="list-style-type: none"> Check the fan speed settings in indoor air quality level and the fan limits.
20	02	2	Airflow/pressure in extract air duct airflow too high for last five minutes.	The unit provides airflow that is 25% above the set point for more than five minutes. <ul style="list-style-type: none"> Check the fan speed settings in indoor air quality level and the fan limits.
20	03	1	Airflow/pressure in extract air duct too low	The unit is providing an airflow/pressure that is 25% below the setpoint. <ul style="list-style-type: none"> Check the fan speed settings in indoor air quality level and the fan limits.
20	04	2	Airflow/pressure in extract air duct airflow too low for last five minutes	The unit has provided airflow/pressure that is 25 % below the set point for more than 5 minutes. <ul style="list-style-type: none"> Check the fan speed settings in indoor air quality level and the fan limits.
20	05	1	Airflow/pressure in supply air duct too high	The unit provides airflow that is 25% above the setpoint. <ul style="list-style-type: none"> Check the fan speed settings in indoor air quality level and the fan limits.
20	06	2	Airflow/pressure in supply air duct airflow too high for last five minutes	The unit provides airflow that is 25% above the set point for more than five minutes. <ul style="list-style-type: none"> Check the fan speed settings in indoor air quality level and the fan limits.
20	07	1	Airflow/pressure in supply air duct too low	The unit is providing an airflow/pressure that is 25% below the setpoint. <ul style="list-style-type: none"> Check the fan speed settings in indoor air quality level and the fan limits.
20	08	2	Airflow/pressure in supply air duct airflow too low for last five minutes	The unit has provided airflow/pressure that is 25 % below the set point for more than 5 minutes. <ul style="list-style-type: none"> Check the fan speed settings in indoor air quality level and the fan limits.
20	09	1	Minimum airflow for cooling/heating units in the supply air duct was not achieved	The required supply airflow for operating cooling/heating units was not achieved. <ul style="list-style-type: none"> Check the fan speed settings in indoor air quality level and the fan limits.
20	10	3	Minimum supply air duct airflow for cooling/warming not achieved in last five minutes	The required supply airflow for operating cooling/heating units was not achieved within five minutes. <ul style="list-style-type: none"> Check the fan speed settings in indoor air quality level and the fan limits.

CO ₂ sensor				
Unit	Fault code	Category	Alarm description	Troubleshooting (See appendix 1: "Simplified diagrams" for the location of dampers, sensors, air directions, etc.)
xx	yy	z		
21	01	2	No modbus communication to MIO CO ₂ module	<ul style="list-style-type: none"> • Check the modbus cable between the connection board (EXact)/main board (EXact2) and MIO module. • Check the modbus cable from the MIO module to the other units for faulty wiring. • Check the DIP-switch settings in the MIO module, refer to the MIO manual if necessary
21	02	2	CO ₂ level below 100 ppm. CO ₂ sensor may be defective.	<ul style="list-style-type: none"> • CO₂ sensor may be defective and should be replaced.
21	03	2	CO ₂ input via BMS selected and BMS has not been configured.	<ul style="list-style-type: none"> • Configure BMS.

Temperature sensor MIO-TS				
Unit	Fault code	Category	Alarm description	Troubleshooting (See appendix 1: "Simplified diagrams" for the location of dampers, sensors, air directions, etc.)
xx	yy	z		
22	01	2	No modbus communication to MIO-TS module	<ul style="list-style-type: none"> • Check the modbus cable between the connection board (EXact)/main board (EXact2) and MIO module. • Check the modbus cable from the MIO module to the other units for faulty wiring. • Check the DIP-switch settings in the MIO module, refer to the MIO manual if necessary
22	02	2	Temperature sensor disconnected	<ul style="list-style-type: none"> • Check the sensor's resistance complies with the actual temperature. See temperature resistance table appendix 2. • If the sensor resistance has significantly changed in value, it should be replaced.
22	03	2	Temperature sensor short-circuited	<ul style="list-style-type: none"> • Check the sensor's resistance complies with the actual temperature. See temperature resistance table appendix 2. • If the sensor resistance has significantly changed in value, it should be replaced.

Humidity sensor RH				
Unit	Fault code	Category	Alarm description	Troubleshooting (See appendix 1: "Simplified diagrams" for the location of dampers, sensors, air directions, etc.)
xx	yy	z		
23	01	2	No modbus communication to MIO-RH module	<ul style="list-style-type: none"> • Check the modbus cable between the connection board (EXact)/main board (EXact2) and MIO module. • Check the modbus cable from the MIO module to the other units for faulty wiring. • Check the DIP-switch settings in the MIO module, refer to the MIO manual if necessary
23	02	2	Humidity level is below 2% – RH sensor may be defective	<ul style="list-style-type: none"> • Humidity sensor may be defective and should be replaced
23	03	2	RH input via BMS selected and BMS has not been configured.	<ul style="list-style-type: none"> • Configure BMS.

Motion sensor PIR				
Unit	Fault code	Category	Alarm description	Troubleshooting (See appendix 1: "Simplified diagrams" for the location of dampers, sensors, air directions, etc.)
xx	yy	z		
24	01	2	No modbus communication to PIR module	<ul style="list-style-type: none"> • Check the modbus cable between the connection board (EXact)/main board (EXact2) and PIR module. • Check the modbus cable from the MCCW module to the other units for faulty wiring. • Check the DIP switch settings in the PIR module; refer to the MIO module manual or the PIRB-AS manual if necessary.
24	02	2	PIR input via BMS selected and BMS has not been configured.	<ul style="list-style-type: none"> • Configure BMS.

External cooling unit (MXCU) sensor				
Unit	Fault code	Category	Alarm description	Troubleshooting (See appendix 1: "Simplified diagrams" for the location of dampers, sensors, air directions, etc.)
xx	yy	z		
27	01	4	Supply air duct temperature sensor disconnected	<ul style="list-style-type: none"> Check the sensor's resistance complies with the actual temperature. See temperature resistance table appendix 2. If the sensor resistance has significantly changed in value, it should be replaced.
27	02	4	Supply air duct temperature sensor short-circuited	<ul style="list-style-type: none"> Check the sensor's resistance complies with the actual temperature. See temperature resistance table appendix 2. If the sensor resistance has significantly changed in value, it should be replaced.

External cooling unit (MXCU) control				
Unit	Fault code	Category	Alarm description	Troubleshooting (See appendix 1: "Simplified diagrams" for the location of dampers, sensors, air directions, etc.)
xx	yy	z		
28	01	1	Module configured incorrectly. Check CN6 on circuit board	<ul style="list-style-type: none"> Check jumper in CN6 connector on cooling control circuit board. There must be a jumper across 4 and 6, and across 5 and 6.
28	06	1	Cooling control currently run locally due to service	Cooling control temporarily controlled by Lodam Multi Tool. Override lasts for max. 60 minutes.
28	07	1	Cooling control safety functions overridden locally due to service	Cooling control temporarily controlled by Lodam Multi Tool. Override lasts for max. 60 minutes.
28	13	4	Cooling control detected which was not selected in the VEX/CX configuration	The cooling unit is configured in menu 3.4 "Accessories".
28	14	4	Cooling control configured incorrectly in connection with the selected VEX/CX configuration	<ul style="list-style-type: none"> Check jumper in CN6 connector on cooling control circuit board. There must be a jumper across 4 and 6, and across 5 and 6.
28	15	4	No modbus communication to cooling control	<ul style="list-style-type: none"> Check the modbus cable between the connection board (EXact)/main board (EXact2) and MXCU module. Check the modbus cable from the MXCU module to the other units for faulty wiring.

MCCW				
Unit	Fault code	Category	Alarm description	Troubleshooting (See appendix 1: "Simplified diagrams" for the location of dampers, sensors, air directions, etc.)
xx	yy	z		
30	01	4	Supply air duct temperature sensor disconnected	<ul style="list-style-type: none"> • Check the sensor's resistance complies with the actual temperature. See temperature resistance table appendix 2. • If the sensor resistance has significantly changed in value, it should be replaced.
30	02	4	Supply air duct temperature sensor short-circuited	<ul style="list-style-type: none"> • Check the sensor's resistance complies with the actual temperature. See temperature resistance table appendix 2. • If the sensor resistance has significantly changed in value, it should be replaced.
30	05	4	Supply water pipe temperature sensor on water cooling coil disconnected	<ul style="list-style-type: none"> • Check the sensor's resistance complies with the actual temperature. See temperature resistance table appendix 2. • If the sensor resistance has significantly changed in value, it should be replaced.
30	06	4	Supply water pipe temperature sensor on water cooling coil short-circuited	<ul style="list-style-type: none"> • Check the sensor's resistance complies with the actual temperature. See temperature resistance table appendix 2. • If the sensor resistance has significantly changed in value, it should be replaced.

MCCW control				
Unit	Fault code	Category	Alarm description	Troubleshooting (See appendix 1: "Simplified diagrams" for the location of dampers, sensors, air directions, etc.)
xx	yy	z		
31	01	1	Module configured incorrectly. Check CN6 on circuit board	<ul style="list-style-type: none"> Check jumper in CN6 connector on cooling control circuit board. There must be a jumper across 4 and 6, and across 5 and 6.
31	06	1	Cooling control currently run locally due to service	Cooling control temporarily controlled by Lodam Multi Tool. Override lasts for max. 60 minutes.
31	07	1	Cooling control safety functions overridden locally due to service	Cooling control temporarily controlled by Lodam Multi Tool. Override lasts for max. 60 minutes.
31	13	4	Cooling control detected which was not selected in the VEX/CX configuration	In menu 3. "Accessories" is configured for the cooling unit
31	14	4	Cooling control configured incorrectly in connection with the selected VEX/CX configuration	<ul style="list-style-type: none"> Check jumper in CN6 connector on cooling control circuit board. There must be a jumper across 4 and 6, and across 5 and 6.
31	15	4	No modbus communication to cooling control	<ul style="list-style-type: none"> Check the modbus cable between the connection board and the MCCW module Check the modbus cable from the MCCW module to the other units for faulty wiring

De-icing				
Unit	Fault code	Category	Alarm description	Troubleshooting (See appendix 1: "Simplified diagrams" for the location of dampers, sensors, air directions, etc.)
xx	yy	z		
32	01	3	Pressure loss across counter flow heat exchanger too high, due to soiling	<ul style="list-style-type: none"> Clean the counter flow heat exchanger. Alarm triggered only when outdoor air temperature is above 10 °C.
32	02	4	Pressure drop across counter flow heat exchanger too high, due to icing	<ul style="list-style-type: none"> Counter flow heat exchanger must thaw. Can be thawed by force-starting extract air
32	03	1	De-icing activated because of icing	Information showing the unit running de-icing
32	04	1	Standby mode activated because of too much icing	Information showing the unit is in hibernation mode because of too much icing
32	05	4	De-icing failed	<p>Total number of restarts after hibernation set in Menu 7.4 is exceeded</p> <ul style="list-style-type: none"> Check if outdoor air temperature is still too low. If so, operation can only start again when the temperature has risen
32	06	3	Illegal de-icing method	<ul style="list-style-type: none"> Select correct de-icing method in accordance with section "De-icing methods"
32	07	2	Bypass de-icing is deactivated	<p>MHCW: The return water temperature has fallen below the warning temperature and the frost protection function is active.</p> <ul style="list-style-type: none"> Check that the hot water supply to the heating coil is functioning. <p>If the hot water supply is functioning, check if the motor valve opens and the circulation pump is running.</p> <ul style="list-style-type: none"> Check by turning the unit to "OFF" in the user menu and force start the motor valve and circulation pump in specialist menu 8.3. <p>The alarm resets automatically when the temperature rises above the heat retention level.</p>

Damper				
Unit	Fault code	Category	Alarm description	Troubleshooting (See appendix 1: "Simplified diagrams" for the location of dampers, sensors, air directions, etc.)
xx	yy	z		
33	01	2	BP1: Bypass damper 1 fault	BP1: <ul style="list-style-type: none"> • Check the damper operates freely. Depress the release on the damper motor and rotate the damper. • Go to forced start in menu 8.3 and force the closed damper to open
33	02	2	BP2: Bypass damper 2 faulty	BP2: <ul style="list-style-type: none"> • Check the damper operates freely. Depress the release on the damper motor and rotate the damper. • Go to forced start in menu 8.3 and force the closed damper to open
33	03	2	BP3: Bypass damper 3 faulty	BP3: <ul style="list-style-type: none"> • Check the damper operates freely. Depress the release on the damper motor and rotate the damper. • Go to forced start in menu 8.3 and force the closed damper to open
33	04	2	RAD: Return air damper 1 fault	RAD: <ul style="list-style-type: none"> • Check the damper operates freely • Go to forced start in menu 8.3 and force the closed damper to open • Visually check that the damper operates • A defective unit must be replaced

Modbus Status				
Unit	Fault code	Category	Alarm description	Troubleshooting (See appendix 1: "Simplified diagrams" for the location of dampers, sensors, air directions, etc.)
xx	yy	z		
34	01	1	SendModbusDataReceive fail	Contact EXHAUSTO A/S
34	02	1	SendModbusDataSend fail	Contact EXHAUSTO A/S
34	03	1	SendModbusDataConnect fail	Contact EXHAUSTO A/S
34	04	1	SetRegister Connect fail	Contact EXHAUSTO A/S
34	05	1	SetCoil Connect fail	Contact EXHAUSTO A/S
34	06	1	GetRegister Connect fail	Contact EXHAUSTO A/S

External control				
Unit	Fault code	Category	Alarm description	Troubleshooting (See appendix 1: "Simplified diagrams" for the location of dampers, sensors, air directions, etc.)
xx	yy	z		
35	01	3	No modbus communication to the MIO-AUX1 (extract air) module	<ul style="list-style-type: none"> • Check the modbus cable between the connection board (EXact)/main board (EXact2) and MIO module. • Check the modbus cable from the MIO module to the other units for faulty wiring. • Check the DIP-switch settings in the MIO module, refer to the MIO manual if necessary
35	02	3	No modbus communication to the MIO-AUX2 (supply air) module	<ul style="list-style-type: none"> • Check the modbus cable between the connection board (EXact)/main board (EXact2) and MIO module. • Check the modbus cable from the MIO module to the other units for faulty wiring. • Check the DIP-switch settings in the MIO module, refer to the MIO manual if necessary

EC Controller 1				
Unit	Fault code	Category	Alarm description	Troubleshooting (See appendix 1: "Simplified diagrams" for the location of dampers, sensors, air directions, etc.)
xx	yy	z		
36	02	4	The supply voltage to the EC controller is too low	<ul style="list-style-type: none"> Check for low voltage to EC controller 1
36	03	4	The supply voltage to the EC controller is too high	<ul style="list-style-type: none"> Check for overvoltage to EC controller 1
36	04	1	The EC controller motor is drawing too much current	<ul style="list-style-type: none"> Check the fan impeller can turn freely Check wear on the motor ball bearings
36	06	1	Temperature in the EC controller power module has risen above 90°C	<ul style="list-style-type: none"> Check if the temperature at EC controller 1 exceeded the permitted 35°C when the alarm was tripped. If the temperature has been too high, the unit will restart when the air temperature falls below 35°C.
36	07	4	Temperature in the EC controller power module has risen above 120°C	<ul style="list-style-type: none"> Check if the temperature at EC controller 1 exceeded the permitted 35°C when the alarm was tripped. If the temperature has been too high, the unit will restart when the air temperature falls below 35°C.
36	08	4	EC controller hardware fault	<ul style="list-style-type: none"> Restart unit. If this does not remedy the fault, replace EC controller 1.
36	09	4	MCE FAULT	<ul style="list-style-type: none"> Restart unit. If this does not remedy the fault, replace EC controller 1.
36	10	4	Motor blocked	<ul style="list-style-type: none"> EC controller motor is blocked
36	11	4	EC controller power supply to motor has lost a phase	<ul style="list-style-type: none"> Check the cable between EC controller 1 and motor Check for a short circuit in the motor windings
36	14	4	The software version in the EC controller is out of date	<ul style="list-style-type: none"> Upgrade software in EC controller 1.
36	15	4	EC controller does not fit VEX/CX size	<ul style="list-style-type: none"> Check whether the EC controller fits the VEX/CX size, see VEX/CX configuration.
36	16	4	No modbus communication to EC controller	<ul style="list-style-type: none"> Check the modbus cable between the main board and the EC controller

EC Controller 2				
Unit	Fault code	Category	Alarm description	Troubleshooting (See appendix 1: "Simplified diagrams" for the location of dampers, sensors, air directions, etc.)
xx	yy	z		
37	02	4	The supply voltage to the EC controller is too low	<ul style="list-style-type: none"> Check for low voltage to EC controller 2
37	03	4	The supply voltage to the EC controller is too high	<ul style="list-style-type: none"> Check for overvoltage to EC controller 2
37	04	1	The EC controller motor is drawing too much current	<ul style="list-style-type: none"> Check the fan impeller can turn freely Check wear on the motor ball bearings
37	06	1	Temperature in the EC controller power module has risen above 90°C	<ul style="list-style-type: none"> Check if the temperature at EC controller 2 exceeded the permitted 35°C when the alarm was tripped. If the temperature has been too high, the unit will restart when the air temperature falls below 35°C.
37	07	4	Temperature in the EC controller power module has risen above 120°C	<ul style="list-style-type: none"> Check if the temperature at EC controller 2 exceeded the permitted 35°C when the alarm was tripped. If the temperature has been too high, the unit will restart when the air temperature falls below 35°C.
37	08	4	EC controller hardware fault	<ul style="list-style-type: none"> Restart unit. If this does not remedy the fault, replace EC controller 2.
37	09	4	MCE FAULT	<ul style="list-style-type: none"> Restart unit. If this does not remedy the fault, replace EC controller 2.
37	10	4	Motor blocked	<ul style="list-style-type: none"> EC controller motor is blocked
37	11	4	EC controller power supply to motor has lost a phase	<ul style="list-style-type: none"> Check the cable between EC controller 2 and motor Check for a short circuit in the motor windings
37	14	4	The software version in the EC controller is out of date	<ul style="list-style-type: none"> Upgrade software in EC controller 2.
37	15	4	EC controller does not fit VEX/CX size	<ul style="list-style-type: none"> Check whether the EC controller fits the VEX/CX size, see VEX/CX configuration.
37	16	4	No modbus communication to EC controller	<ul style="list-style-type: none"> Check the modbus cable between the main board and the EC controller

Analog Motor 1				
Unit	Fault code	Category	Alarm description	Troubleshooting (See appendix 1: "Simplified diagrams" for the location of dampers, sensors, air directions, etc.)
xx	yy	z		
38	01	4	Motor 1 not running	<ul style="list-style-type: none"> Check motor cable Check if motor is blocked

Analog Motor 2				
Unit	Fault code	Category	Alarm description	Troubleshooting (See appendix 1: "Simplified diagrams" for the location of dampers, sensors, air directions, etc.)
xx	yy	z		
39	01	4	Motor 2 not running	<ul style="list-style-type: none"> • Check motor cable • Check if motor is blocked

Configuration				
Device	Fault code	Category	Alarm description	Troubleshooting (See appendix 1: "Simplified diagrams" for the location of dampers, sensors, air directions, etc.)
xx	yy	z		
40	01	4	Type has not been configured	<ul style="list-style-type: none"> • Configure the VEX/CX in menu 3.3
40	02	4	VEX size has not been configured	<ul style="list-style-type: none"> • Configure the VEX/CX size in menu 3.3
40	03	4	VEX orientation has not been configured	<ul style="list-style-type: none"> • Configure orientation in menu 3.3

Dining solution				
Unit	Fault code	Category	Alarm description	Troubleshooting (See appendix 1: "Simplified diagrams" for the location of dampers, sensors, air directions, etc.)
xx	yy	z		
42	01	4	Motor control 1 does not fit Dining Solution	<ul style="list-style-type: none"> • Control of external extract air fan, which replaces internal extract air fan

Cooling Alarm				
Unit	Fault code	Category	Alarm description	Troubleshooting (See appendix 1: "Simplified diagrams" for the location of dampers, sensors, air directions, etc.)
xx	yy	z		
43	01	3	Temperature sensor after the CCW surface in the supply air duct is short-circuited.	<ul style="list-style-type: none"> Check the sensor's resistance complies with the actual temperature. See temperature resistance table appendix 2. If the sensor resistance has significantly changed in value, it should be replaced.
43	02	3	Temperature sensor after the CCW surface in the supply air duct is open-circuit.	<ul style="list-style-type: none"> Check the sensor's resistance complies with the actual temperature. See temperature resistance table appendix 2. If the sensor resistance has significantly changed in value, it should be replaced.
43	03	3	The temperature sensor in the supply to the CCW surface in the extract air duct is short-circuited.	<ul style="list-style-type: none"> Check the sensor's resistance complies with the actual temperature. See temperature resistance table appendix 2. If the sensor resistance has significantly changed in value, it should be replaced.
43	04	3	The temperature sensor in the supply to the CCW surface in the extract air duct is open-circuit.	<ul style="list-style-type: none"> Check the sensor's resistance complies with the actual temperature. See temperature resistance table appendix 2. If the sensor resistance has significantly changed in value, it should be replaced.
43	05	3	Pressure gas temperature sensor has short-circuited.	<ul style="list-style-type: none"> Check the sensor's resistance complies with the actual temperature. See temperature resistance table appendix 2. If the sensor resistance has significantly changed in value, it should be replaced.
43	06	3	Pressure gas temperature sensor has been interrupted.	<ul style="list-style-type: none"> Check the sensor's resistance complies with the actual temperature. See temperature resistance table appendix 2. If the sensor resistance has significantly changed in value, it should be replaced.
43	07	3	Suction gas pressure sensor has short-circuited.	<ul style="list-style-type: none"> Check connection between sensor and cooling control, Contact EXHAUSTO service.
43	08	3	Suction gas pressure sensor has been interrupted.	<ul style="list-style-type: none"> Check connection between sensor and cooling control, Contact EXHAUSTO service.
43	09	3	Pressure gas pressure sensor has short-circuited.	<ul style="list-style-type: none"> Check connection between sensor and cooling control, Contact EXHAUSTO service.
43	10	3	Pressure gas pressure sensor has been interrupted.	<ul style="list-style-type: none"> Check connection between sensor and cooling control, Contact EXHAUSTO service.
43	11	3	Low pressure guard has triggered a stop.	Call a cooling technician.
43	12	3	High pressure guard has triggered a stop.	Call a cooling technician. Three operational stops due to high pressure are permitted before this alarm is triggered.

Cooling Alarm				
Unit	Fault code	Category	Alarm description	Troubleshooting (See appendix 1: "Simplified diagrams" for the location of dampers, sensors, air directions, etc.)
xx	yy	z		
43	13	3	High pressure gas temperature has triggered a stop.	Call a cooling technician.
43	14	3	MC alarm output activated.	Read any error code on the motor controller display and contact service. This alarm cannot be cancelled via the HMI panel until it has been cancelled on the cooling unit's motor controller: <ul style="list-style-type: none"> • Disconnect the supply voltage to the cooling unit for 1 minute via the isolation switch on the cooling unit. • Then cancel the alarm via the HMI panel.
43	15	4	Unknown configuration.	Chiller size has not been configured. Contact EXHAUSTO service.

Cooling status				
Unit	Fault code	Category	Alarm description	Troubleshooting (See appendix 1: "Simplified diagrams" for the location of dampers, sensors, air directions, etc.)
xx	yy	z		
44	02	2	Suction pressure is low.	The unit is running in reduced mode.
44	03	2	Pressure gas pressure is high.	The unit is running in reduced mode.
44	10	2	Reduced operation of CH cooling unit due to low flow temperature to CCW coil exhaust.	CH cooling unit is running in reduced mode due to low supply temperature to the coil in the exhaust duct. <ul style="list-style-type: none"> • Check that the frost protection level is correctly set for the glycol mixture. • Increase the air flow.
44	11	2	Blocked operation of CH cooling unit due to cut-out at too low flow temp., less than 3h ago.	CH cooling unit has stopped due to low supply temperature to the coil in the exhaust duct. <ul style="list-style-type: none"> • Check that the frost protection level is correctly set for the glycol mixture. • Increase the air flow.
44	15	4	CH cooling unit has not been correctly configured.	A CH cooling unit has been found, but the unit is not selected in the "Accessories" menu.
44	16	4	CH cooling unit communication error.	Communication to the cooling pump unit has been interrupted. <ol style="list-style-type: none"> 1. Check the unit's supply voltage. 2. Check the modbus connection between the EXact control system and the CH cooling unit.

MXHP				
Unit	Fault code	Category	Alarm description	Troubleshooting (See appendix 1: "Simplified diagrams" for the location of dampers, sensors, air directions, etc.)
xx	yy	z		
45	01	3	Supply air duct temperature sensor disconnected	<ul style="list-style-type: none"> Check the sensor's resistance complies with the actual temperature. See temperature resistance table appendix 2. If the sensor resistance has significantly changed in value, it should be replaced.
45	02	3	Supply air duct temperature sensor short-circuited	<ul style="list-style-type: none"> Check the sensor's resistance complies with the actual temperature. See temperature resistance table appendix 2. If the sensor resistance has significantly changed in value, it should be replaced.
45	03	3	External DX unit has an active alarm	<p>A general alarm has been received from the external DX unit.</p> <ul style="list-style-type: none"> Check the control/HMI on the external DX unit for information about the error type and how to remedy it.
45	04	3	Menu settings have not been confirmed	<p>Setup of MXHP in HMI menu 3.1.9 has not been confirmed.</p> <ul style="list-style-type: none"> Review the setup and confirm it to remedy the error.

MXHP control				
Unit	Fault code	Category	Alarm description	Troubleshooting (See appendix 1: "Simplified diagrams" for the location of dampers, sensors, air directions, etc.)
xx	yy	z		
46	01	1	Module configured incorrectly. Check CN6 on circuit board	<ul style="list-style-type: none"> Check the jumper in the CN6 connector on the control circuit board. <p>There must be a jumper across 4 and 6, across 5 and 6, and across 7 and 8.</p>
46	06	1	Cooling control currently run locally due to service	Override temporarily controlled by Lodam Multi Tool. Override lasts for max. 60 minutes.
46	07	1	Cooling control safety functions overridden locally due to service	Override temporarily controlled by Lodam Multi Tool. Override lasts for max. 60 minutes.
46	13	4	Cooling control detected which was not selected in the VEX/CX configuration	In menu 3. "Accessories" is configured for the cooling unit
46	14	4	Cooling control configured incorrectly in connection with the selected VEX/CX configuration	<ul style="list-style-type: none"> Check the jumper in the CN6 connector on the control circuit board. <p>There must be a jumper across 4 and 6, across 5 and 6, and across 7 and 8.</p>
46	15	4	No modbus communication to cooling control	<ul style="list-style-type: none"> Check the modbus cable between the connection board (EX-act)/main board (EXact2) and the MXHP module. Check the modbus cable from the MXHP module to the other units for faulty wiring.

MCOCW Alarm				
Unit	Fault code	Category	Alarm description	Troubleshooting (See appendix 1: "Simplified diagrams" for the location of dampers, sensors, air directions, etc.)
xx	yy	z		
47	05	3	External pump or DX unit has an active alarm	A general alarm has been received from the external pump or DX unit. <ul style="list-style-type: none"> Check the control/HMI on the external pump or DX unit for information about the error type and how to remedy it.
47	06	4	Menu settings have not been confirmed	Setup of MCOCW in HMI menu 3.1.10 has not been confirmed. <ul style="list-style-type: none"> Review the setup and confirm it to remedy the error.
47	09	3	Return water temp. becoming too low. VEX/CX running in reduced mode and with frost protection.	HCW: <ul style="list-style-type: none"> Check that the hot water supply to the heating coil is functioning. <p>If the hot water supply is functioning, check if the motor valve opens and the circulation pump is running.</p> <ul style="list-style-type: none"> Check by turning the unit to "OFF" in the user menu and force start the motor valve and circulation pump in specialist menu 8.3. <p>The alarm resets automatically when the temperature rises above the heat retention level.</p>
47	10	3	Return water temp. too low. Frost protection activated. VEX/CX temporarily stopped.	HCW: <ul style="list-style-type: none"> Check that the hot water supply to the heating coil is functioning. <p>If the hot water supply is functioning, check if the motor valve opens and the circulation pump is running.</p> <ul style="list-style-type: none"> Check by turning the unit to "OFF" in the user menu and force start the motor valve and circulation pump in specialist menu 8.3. <p>The alarm resets automatically when the temperature rises above the heat retention level.</p>
47	11	3	Return water temp. measured by external sensor becoming too low. VEX/CX running in reduced mode.	HCW: <ul style="list-style-type: none"> Check that the hot water supply to the heating coil is functioning. <p>If the hot water supply is functioning, check if the motor valve opens and the circulation pump is running.</p> <ul style="list-style-type: none"> Check by turning the unit to "OFF" in the user menu and force start the motor valve and circulation pump in specialist menu 8.3. <p>The alarm resets automatically when the temperature rises above the heat retention level.</p>

MCOCW Alarm				
Unit	Fault code	Category	Alarm description	Troubleshooting (See appendix 1: "Simplified diagrams" for the location of dampers, sensors, air directions, etc.)
xx	yy	z		
47	12	3	Return water temp. measured by external sensor becoming too low. VEX/CX temporarily stopped.	<p>HCW:</p> <ul style="list-style-type: none"> • Check that the hot water supply to the heating coil is functioning. <p>If the hot water supply is functioning, check if the motor valve opens and the circulation pump is running.</p> <ul style="list-style-type: none"> • Check by turning the unit to "OFF" in the user menu and force start the motor valve and circulation pump in specialist menu 8.3. <p>The alarm resets automatically when the temperature rises above the heat retention level.</p>
47	13	4	Max. total no. of re-starts within one hour reached.	<p>HCW:</p> <ul style="list-style-type: none"> • Check that the hot water supply to the heating coil is functioning. <p>If the hot water supply is functioning, check if the motor valve opens and the circulation pump is running.</p> <ul style="list-style-type: none"> • Check by turning the unit to "OFF" in the user menu and force start the motor valve and circulation pump in specialist menu 8.3. <p>The alarm resets automatically when the temperature rises above the heat retention level.</p>
47	14	4	Could not increase return water temp. within five minutes after frost protection with VEX/CX stopped.	<p>HCW:</p> <ul style="list-style-type: none"> • Check that the hot water supply to the heating coil is functioning. <p>If the hot water supply is functioning, check if the motor valve opens and the circulation pump is running.</p> <ul style="list-style-type: none"> • Check by turning the unit to "OFF" in the user menu and force start the motor valve and circulation pump in specialist menu 8.3. <p>The alarm resets automatically when the temperature rises above the heat retention level.</p>

MCOCW Sensor				
Unit	Fault code	Category	Alarm description	Troubleshooting (See appendix 1: "Simplified diagrams" for the location of dampers, sensors, air directions, etc.)
xx	yy	z		
48	01	4	Supply air duct temperature sensor disconnected	<ul style="list-style-type: none"> • Check the sensor's resistance complies with the actual temperature. See temperature resistance table appendix 2. • If the sensor resistance has significantly changed in value, it should be replaced.
48	02	4	Supply air duct temperature sensor short-circuited	<ul style="list-style-type: none"> • Check the sensor's resistance complies with the actual temperature. See temperature resistance table appendix 2. • If the sensor resistance has significantly changed in value, it should be replaced.
48	05	4	Supply water pipe temperature sensor on water cooling coil disconnected	<ul style="list-style-type: none"> • Check the sensor's resistance complies with the actual temperature. See temperature resistance table appendix 2. • If the sensor resistance has significantly changed in value, it should be replaced.
48	06	4	Supply water pipe temperature sensor on water cooling coil short-circuited	<ul style="list-style-type: none"> • Check the sensor's resistance complies with the actual temperature. See temperature resistance table appendix 2. • If the sensor resistance has significantly changed in value, it should be replaced.
48	07	4	Return water pipe temperature sensor on water heating coil disconnected	<ul style="list-style-type: none"> • Check the sensor's resistance complies with the actual temperature. See temperature resistance table appendix 2. • If the sensor resistance has significantly changed in value, it should be replaced.
48	08	4	Return water pipe temperature sensor on water heating coil short-circuited	<ul style="list-style-type: none"> • Check the sensor's resistance complies with the actual temperature. See temperature resistance table appendix 2. • If the sensor resistance has significantly changed in value, it should be replaced.
48	09	4	Return water pipe external temperature sensor on water heating coil disconnected	<ul style="list-style-type: none"> • Check the sensor's resistance complies with the actual temperature. See temperature resistance table appendix 2. • If the sensor resistance has significantly changed in value, it should be replaced.
48	10	4	Return water pipe external temperature sensor on water heating coil is short-circuited	<ul style="list-style-type: none"> • Check the sensor's resistance complies with the actual temperature. See temperature resistance table appendix 2. • If the sensor resistance has significantly changed in value, it should be replaced.

MCOCW Control				
Unit	Fault code	Category	Alarm description	Troubleshooting (See appendix 1: "Simplified diagrams" for the location of dampers, sensors, air directions, etc.)
xx	yy	z		
49	01	1	Module configured incorrectly. Check CN6 on circuit board	<ul style="list-style-type: none"> Check the jumper in the CN6 connector on the MCOCW module. There must be a jumper across 5 and 6.
49	02	1	Fan speed temporarily reduced	Fan speed temporarily reduced because warning limit for frost protection of water heating coil has been reached.
49	03	1	VEX temporarily stopped	Fan speed temporarily reduced because stop temperature for frost protection of water heating coil has been reached.
49	04	1	VEX stopped	MCOCW is temporarily controlled by the Lodam Multi Tool.
49	06	1	Heat control currently run locally due to service	MCOCW temporarily controlled by Lodam Multi Tool. Override lasts for max. 60 minutes.
49	07	1	Heat control safety functions overridden locally due to service	MCOCW temporarily controlled by Lodam Multi Tool. Override lasts for max. 60 minutes.
49	11	2	Heating has been blocked due to cold water in the feed pipe	EXact has detected a heating requirement, but via TE-SPT has registered cold water in the feed pipe. Heating is therefore blocked for 6 hours. <ul style="list-style-type: none"> Check that there is hot water in the feed pipe if the heating function is required.
49	12	2	Cooling has been blocked due to hot water in the feed pipe	EXact has detected a cooling requirement, but via TE-SPT has registered hot water in the feed pipe. Cooling is therefore blocked for 6 hours. <ul style="list-style-type: none"> Check that there is cold water in the feed pipe if the cooling function is required.
49	13	4	Heat control detected which was not selected in VEX/CX configuration	The heating coil is configured as MCOCW in menu 3.4 "Accessories".
49	14	4	Heat control configured incorrectly in connection with selected VEX/CX configuration	<ul style="list-style-type: none"> Check the jumper in the CN6 connector on the MCOCW module. There must be a jumper across 5 and 6.
49	15	4	No modbus communication to water heat control	<ul style="list-style-type: none"> Check the modbus cable between the connection board (EXact)/main board (EXact2) and the MCOCW module. Check the modbus cable from the MCOCW module to the other units for faulty wiring.

Appendix 1 - Simplified diagrams

Simplified diagrams

Simplified diagrams for unit with chiller

For units with an installed chiller, see the simplified diagrams at the rear of the chiller instructions.

VEX320L

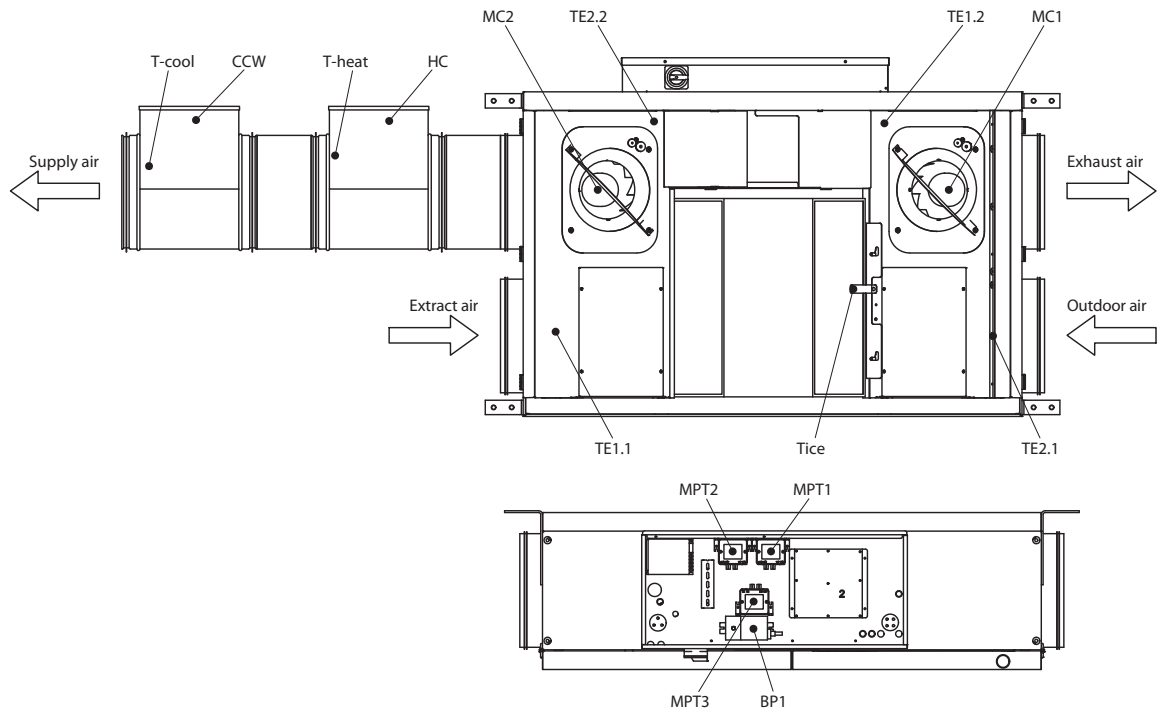

RD13103GB-01

VEX320R

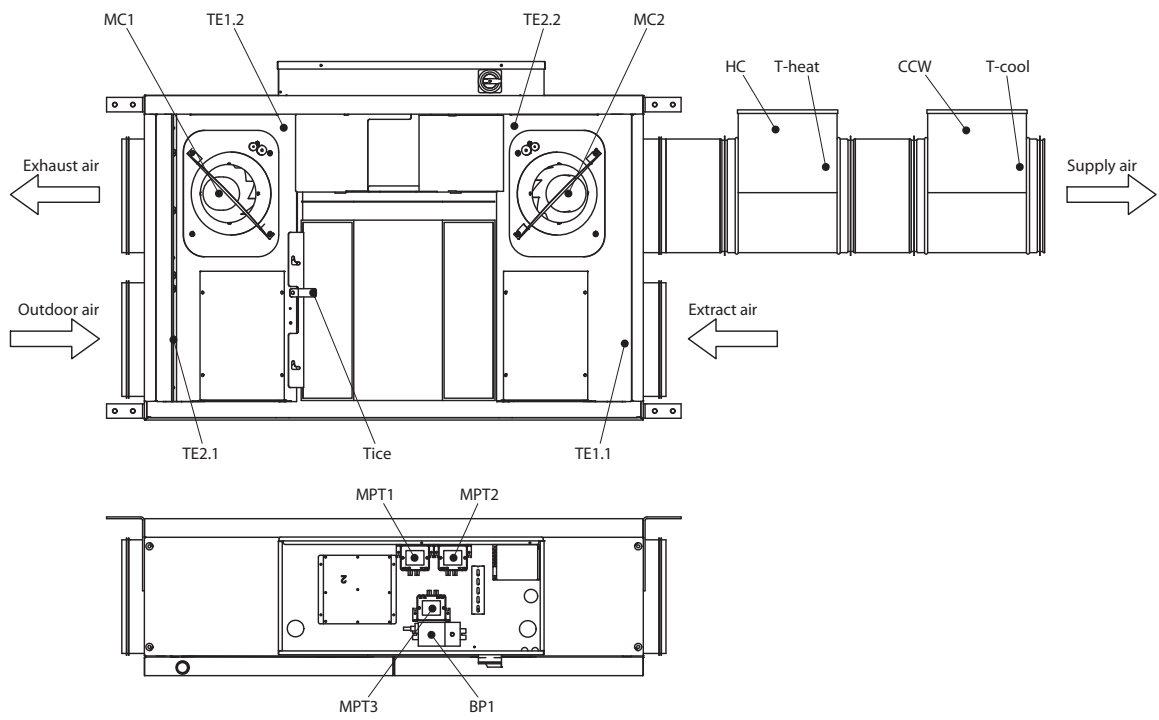

RD13104GB-01

VEX330CL

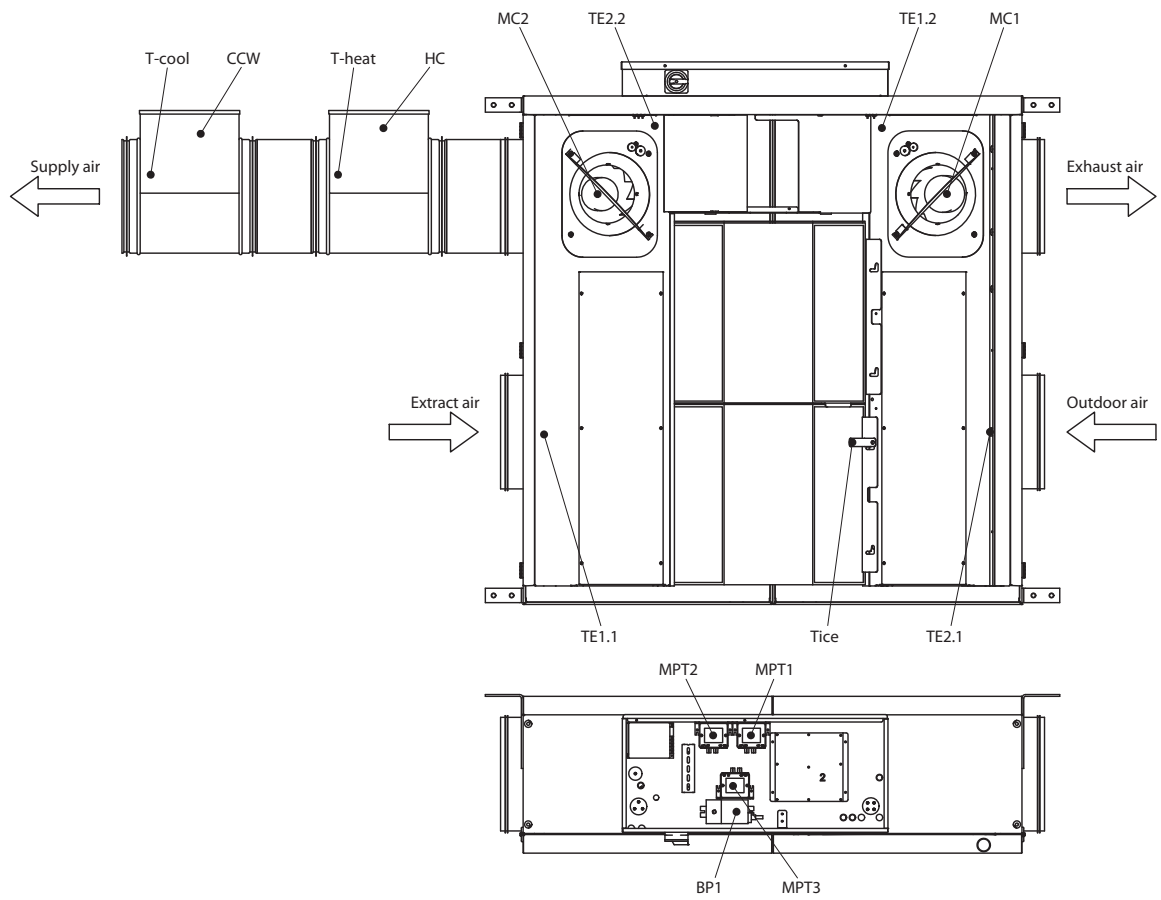

RD1310568-01

VEX330CR

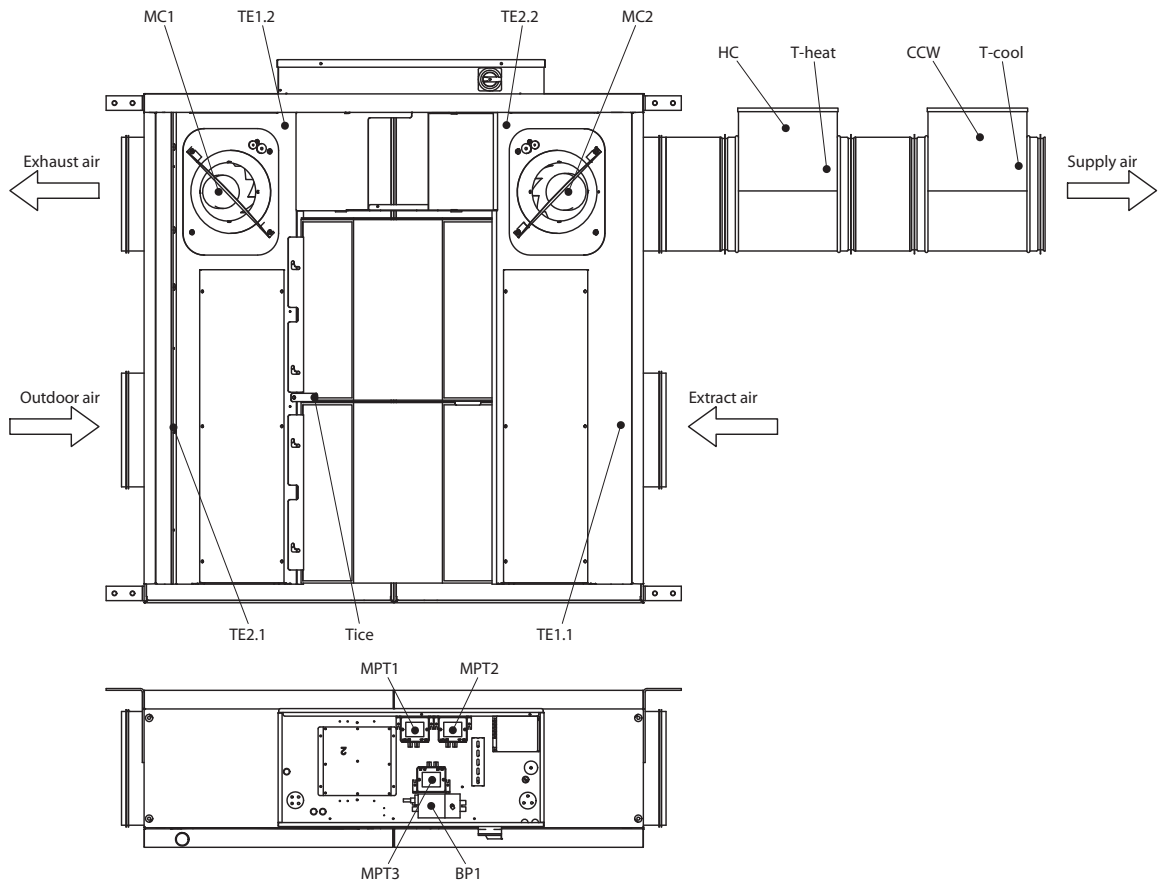

RD13106GB-01

VEX330HL

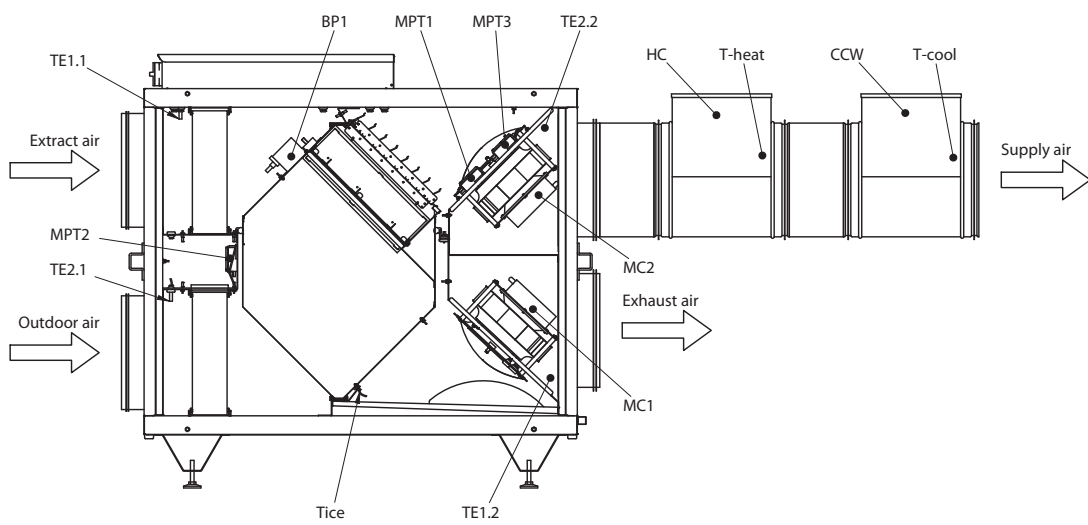

RD13107GB-01

VEX330HR

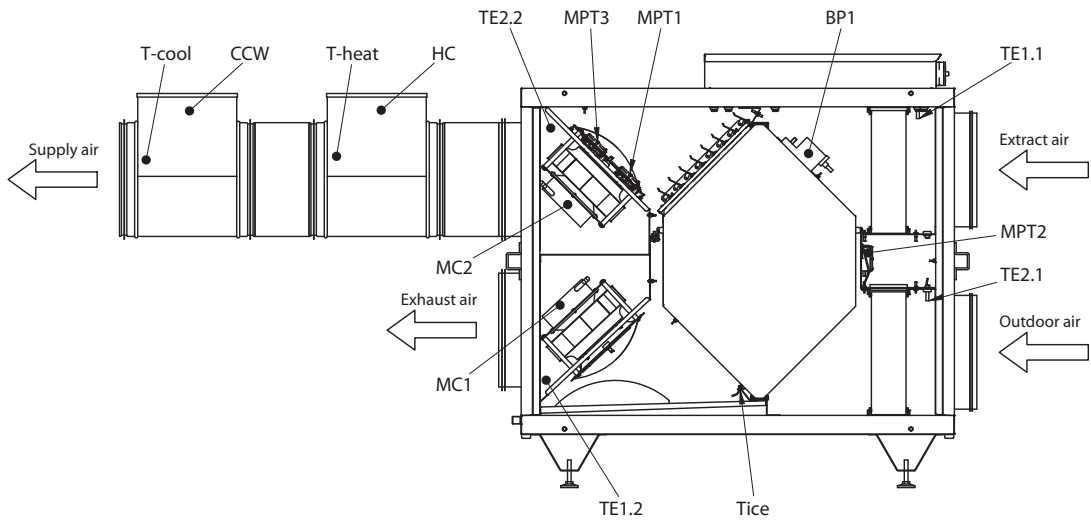

VEX340L

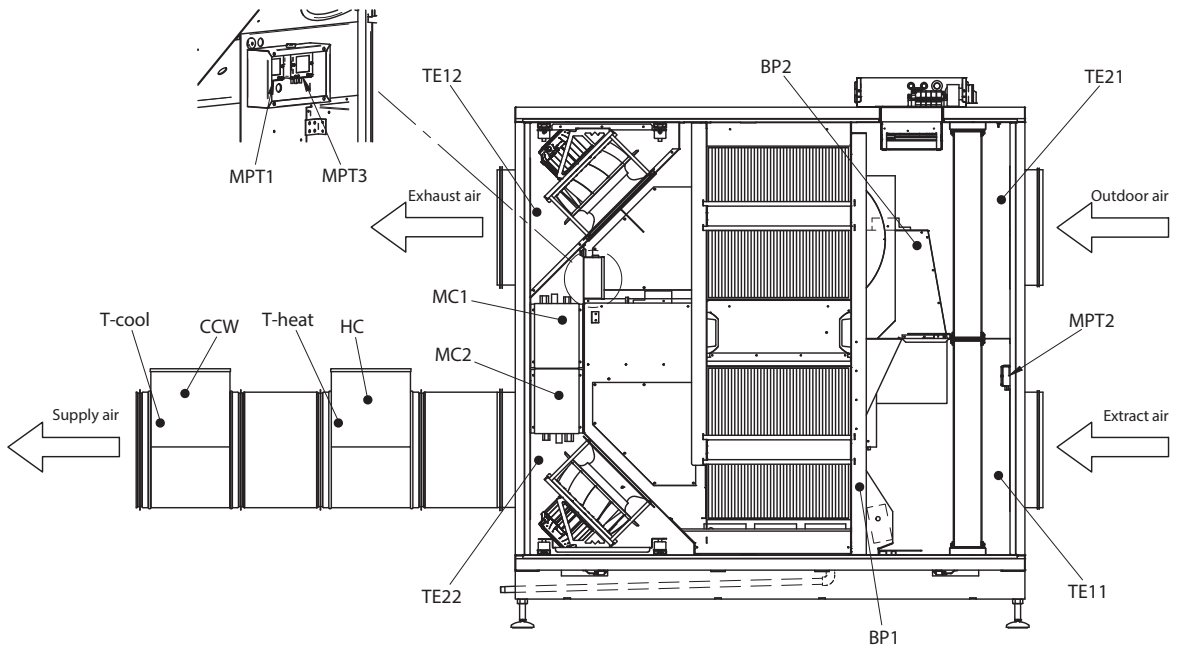

VEX340R

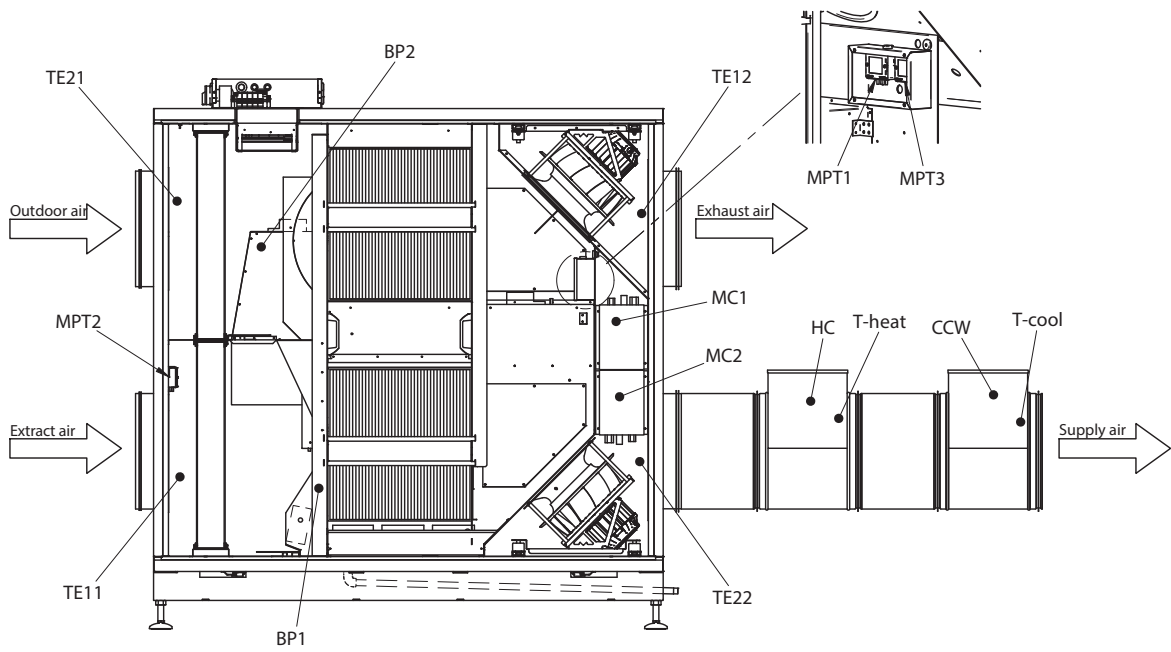

RD12845GB-03

VEX350L - VEX360L

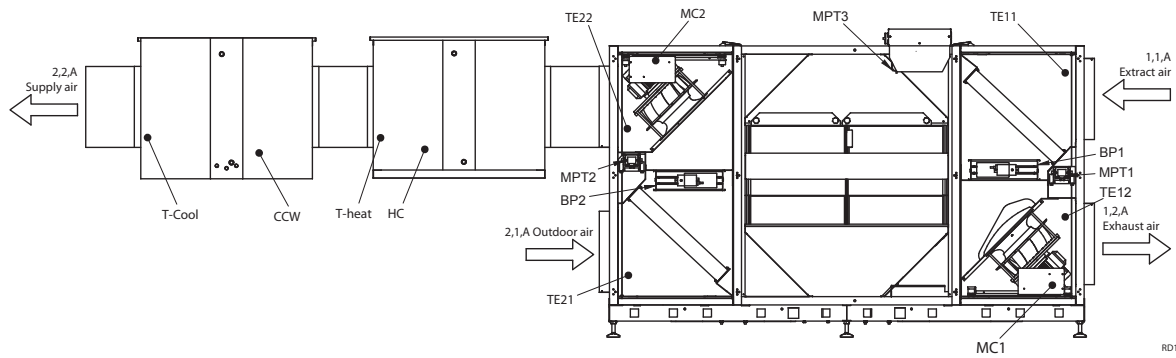

RD12847GB-02

VEX350R- VEX360R

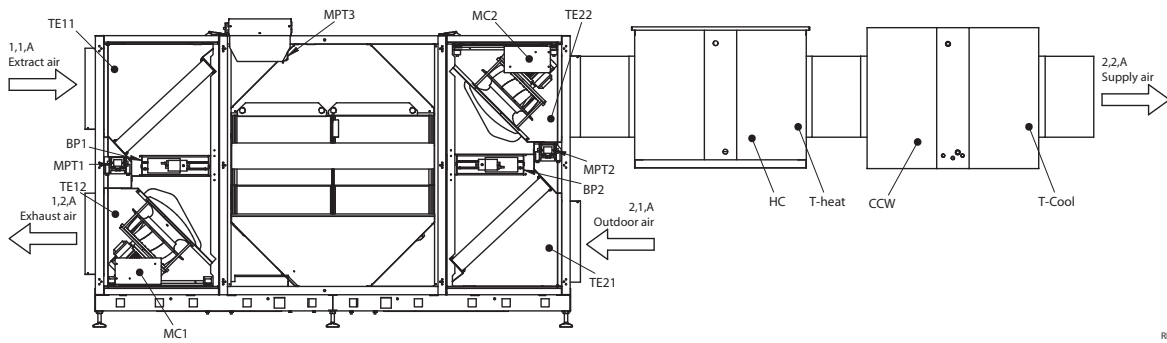

RD12848GB-02

VEX370L HCWi

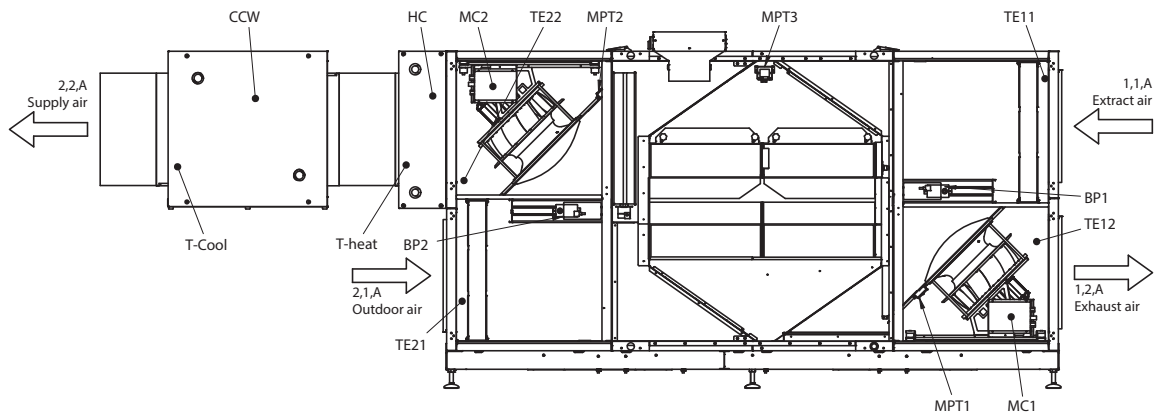

RD13561GB-01

VEX370R HCWi

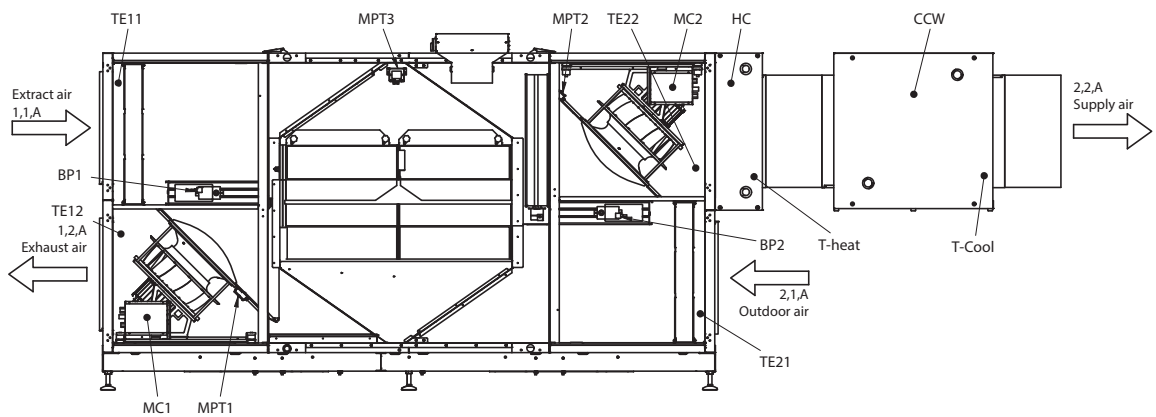

RD13562GB-01

VEX370L

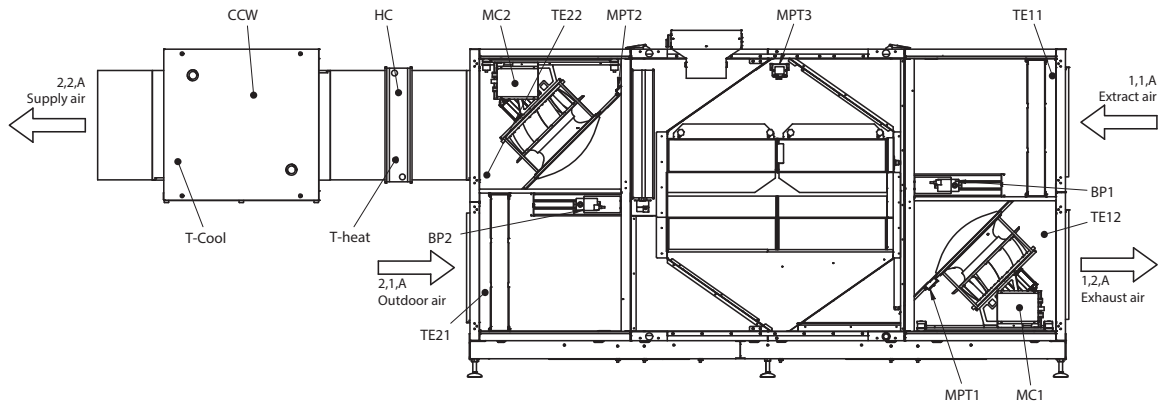

RD1356GB-01

VEX370R

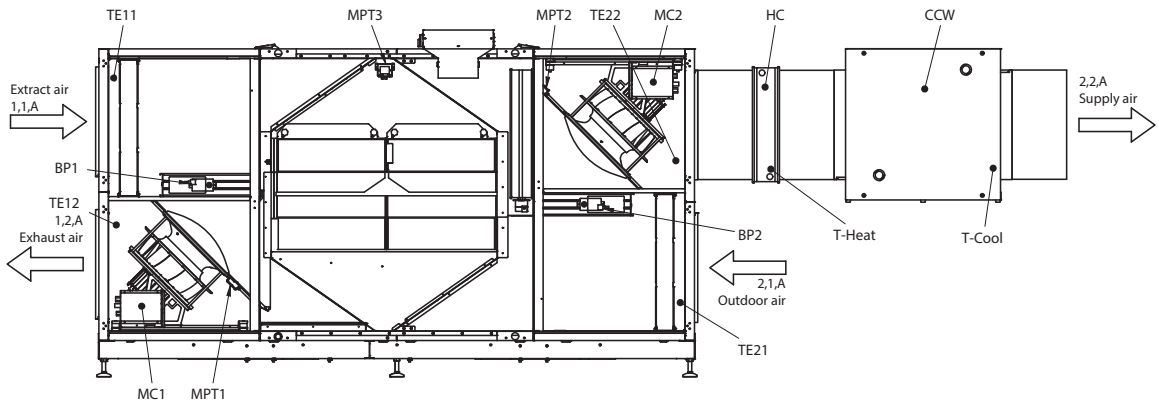

RD1356GB-01

CX340/350

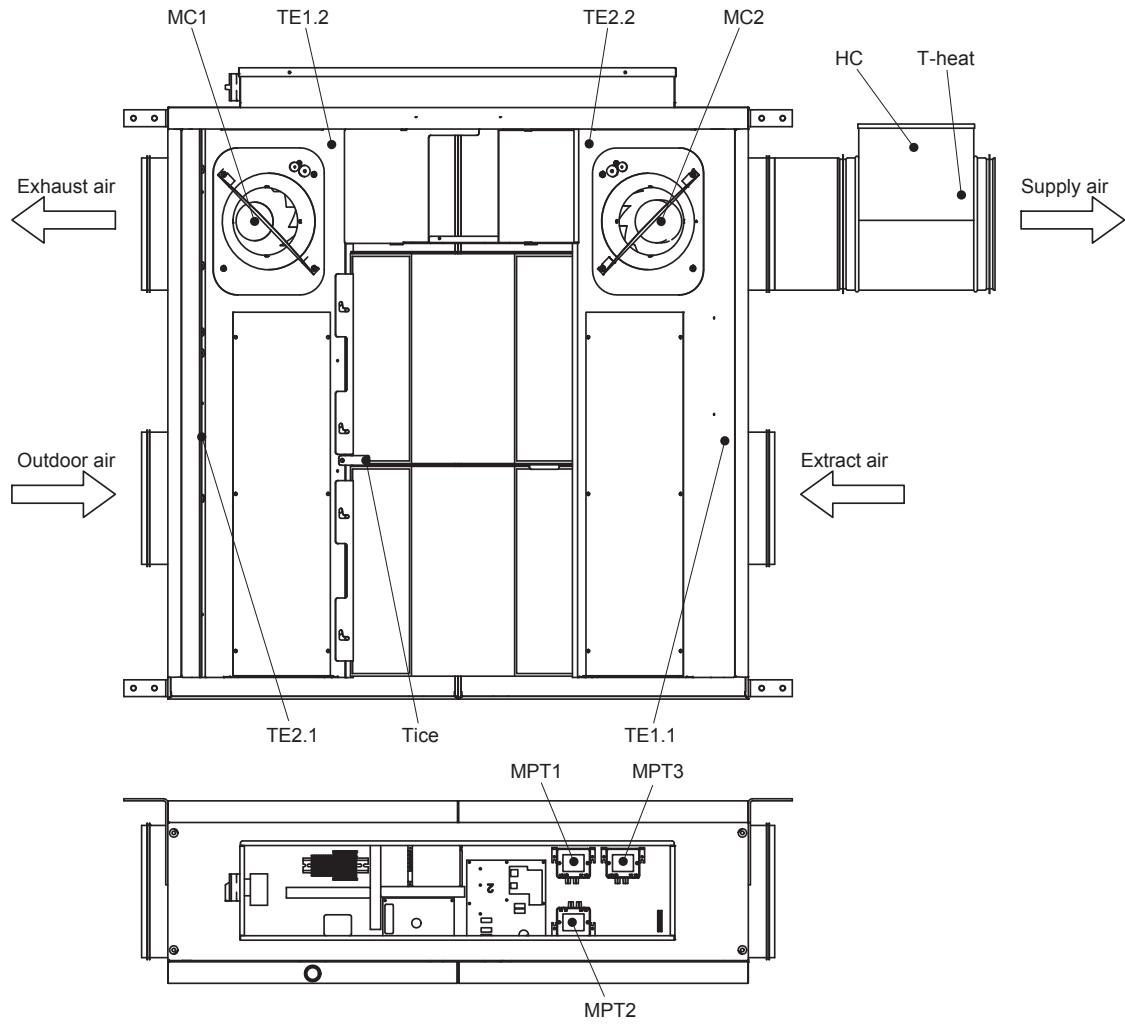

RD13865GB-01

VEX310TR-VEX350TR

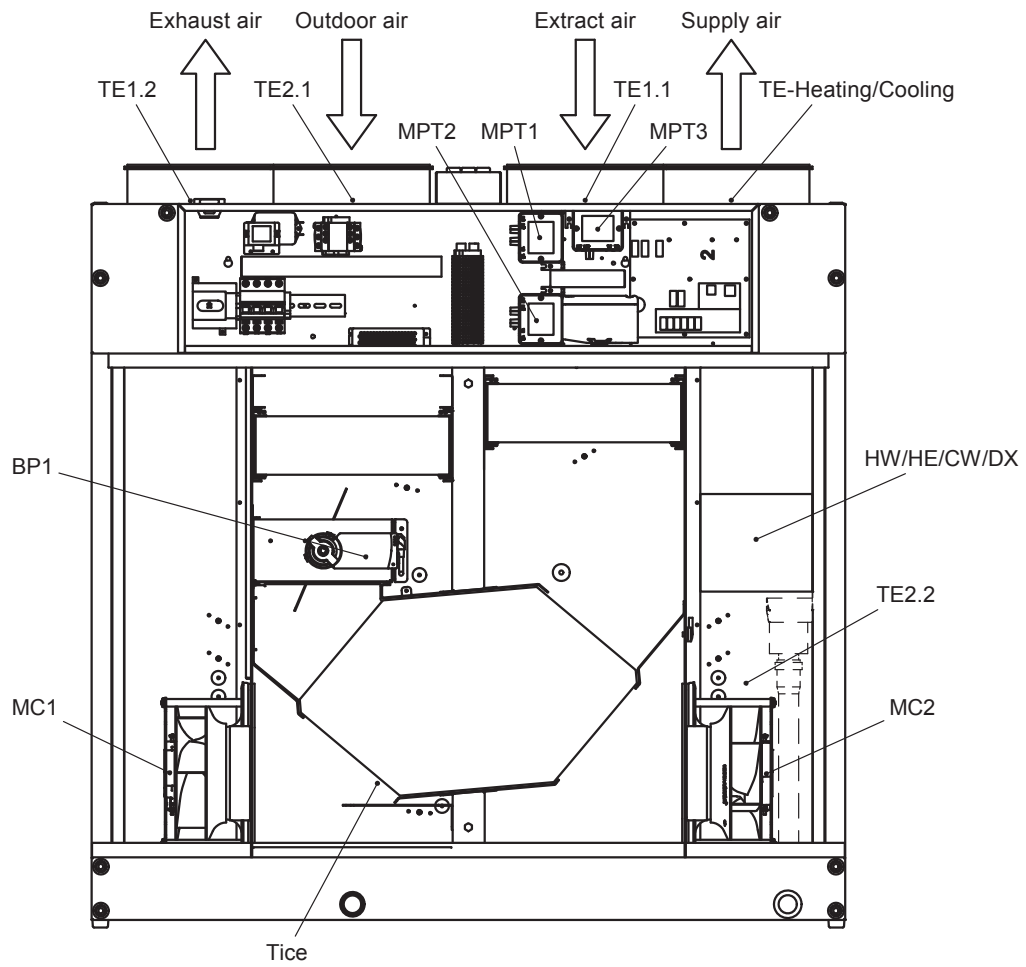

RD14096GB-01

VEX310TL-VEX350TL

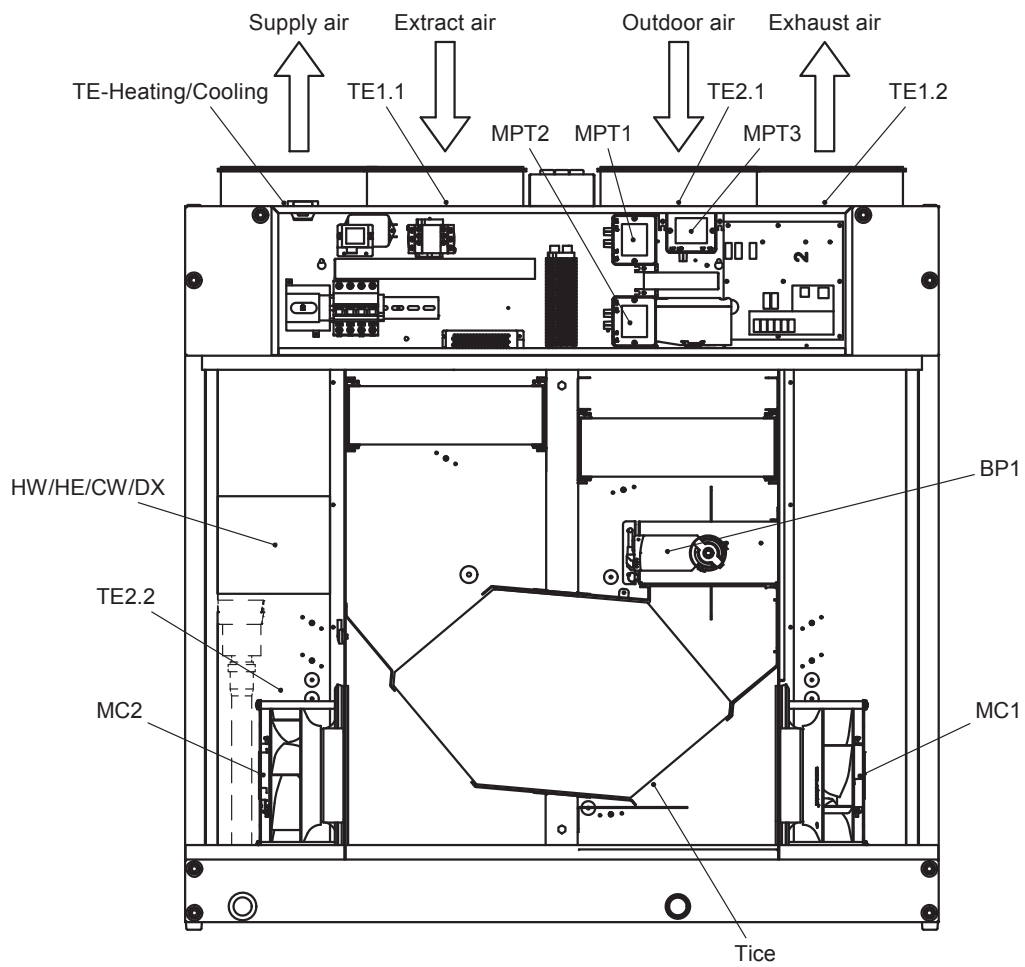

Appendix 2 - Temperature resistance table

Temperature resistance table DC95

Temperature [°C]	Resistance [Ohm]	Temperature [°C]	Resistance [Ohm]	Temperature [°C]	Resistance [Ohm]
-40	324270	-1	34464	38	5774
-39	320139	0	32737	39	5545
-38	299580	1	31107	40	5326
-37	280471	2	29567	41	5116
-36	262702	3	28113	42	4917
-35	246172	4	26739	43	4726
-34	230786	5	25440	44	4543
-33	216458	6	24211	45	4369
-32	203110	7	23049	46	4202
-31	190669	8	21950	47	4042
-30	179068	9	20910	48	3890
-29	168246	10	19924	49	3743
-28	158145	11	18991	50	3604
-27	148714	12	18107	51	3470
-26	139904	13	17270	52	3342
-25	131670	14	16476	53	3219
-24	123972	15	15722	54	3101
-23	116772	16	15008	55	2988
-22	110035	17	14330	56	2880
-21	103727	18	13687	57	2777
-20	97820	19	13076	58	2678
-19	92286	20	12496	59	2582
-18	87099	21	11945	60	2491
-17	82235	22	11421	61	2403
-16	77673	23	10923	62	2319
-15	73391	24	10450	63	2239
-14	69372	25	10000	64	2161
-13	65597	26	9572	65	2087
-12	62050	27	9164	66	2015
-11	58717	28	8776	67	1947
-10	55582	29	8407	68	1881
-9	52634	30	8055	69	1817
-8	49860	31	7720	70	1756
-7	47249	32	7401	71	1698
-6	44790	33	7097	72	1641
-5	42474	34	6807	73	1587
-4	40292	35	6530	74	1535
-3	38234	36	6266	75	1485
-2	36294	37	6014	76	1437

Temperature [°C]	Resistance [Ohm]	Temperature [°C]	Resistance [Ohm]	Temperature [°C]	Resistance [Ohm]
77	1390	93	840.6	109	528.5
78	1346	94	815.7	110	514.0
79	1303	95	791.6	111	500.0
80	1261	96	768.4	112	486.4
81	1221	97	746.0	113	473.2
82	1183	98	724.3	114	460.5
83	1146	99	703.3	115	448.2
84	1110	100	683.1	116	436.3
85	1075	101	663.5	117	424.7
86	1042	102	644.6	118	413.5
87	1010	103	626.3	119	402.7
88	979.4	104	608.6	120	392.1
89	949.6	105	591.5	121	382.0
90	920.9	106	574.9	122	372.1
91	893.2	107	558.9	123	362.5
92	866.4	108	543.4	124	353.2



Scan code and go to addresses at
www.exhausto.com