

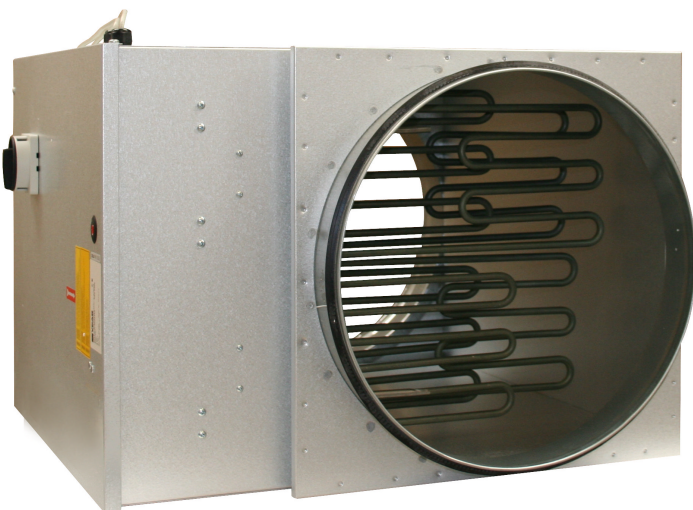



GB

# VEX240 HCE electric heating coil with EXact2 control system



VEX200  
R A N G E  
ROTARY  
HEAT EXCHANGER



-  Product information.....Chapter 1 + 5
-  Mechanical assembly.....Chapter 2
-  Electrical installation.....Chapter 3
-  Commissioning and operation.....Chapter 4

Original instructions



## 1. Product information

<b>1.1. Application</b> .....	<b>3</b>
1.1.1. Application.....	3
<b>1.2. Description</b> .....	<b>3</b>
1.2.1. Construction of the heating coil.....	3
<b>1.3. Principal dimensions</b> .....	<b>4</b>



## 2. Mechanical assembly

<b>2.1. Unpacking</b> .....	<b>5</b>
2.1.1. Weight, 240HCE.....	5
<b>2.2. Position in relation to VEX</b> .....	<b>5</b>
2.2.1. Left/Right positioning.....	5
2.2.2. Correct installation on the duct system.....	5
2.2.3. Location of TE-HCE-SUPPLY.....	6



## 3. Electrical installation

<b>3.1. Connection diagram</b> .....	<b>7</b>
<b>3.2. Connection of Modbus devices</b> .....	<b>8</b>
3.2.1. Connection of Modbus devices.....	8
3.2.2. Cable (type, max. length and termination).....	9



## 4. Commissioning and operation

<b>4.1. Warnings, commissioning</b> .....	<b>10</b>
4.1.1. Warnings, overheating.....	10
<b>4.2. Safety features</b> .....	<b>10</b>
4.2.1. Safety features.....	10
<b>4.3. Maintenance and alarms</b> .....	<b>11</b>



## 5. Technical specifications

<b>5.1. Electric heating coil</b> .....	<b>12</b>
<b>5.2. Spare parts</b> .....	<b>12</b>



# 1. Product information

## 1.1 Application

### 1.1.1 Application

The EXHAUSTO VEX200 HCE heating coil is an accessory to the VEX200 range and is used to increase the temperature of the supply air.

Designations used in these instructions

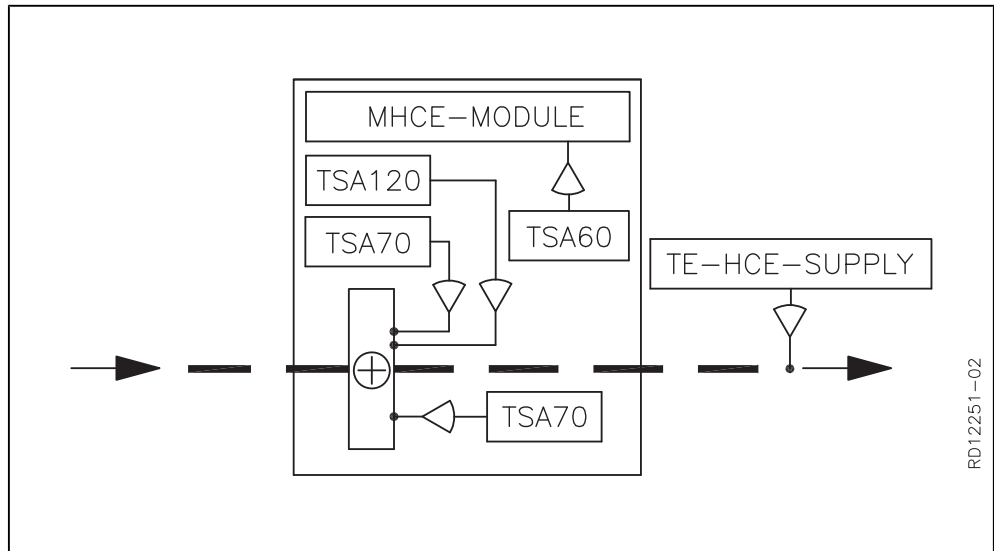

RD12251-02

Component term	Function
MHCE module	Control box, located in the heating coil
TSA120	Overheating protection, electric heating coil (manual reset)
TSA70	Overheating protection, electric heating coil (automatic reset)
TSA60	Overheating protection, control system (manual reset)
TE-HCE-SUPPLY	Temperature sensor, supply air

For more information about resetting thermal cut-outs, see section "Safety features"

## 1.2 Description

### 1.2.1 Construction of the heating coil

General drawing

The drawing below shows the construction of the heating coil:

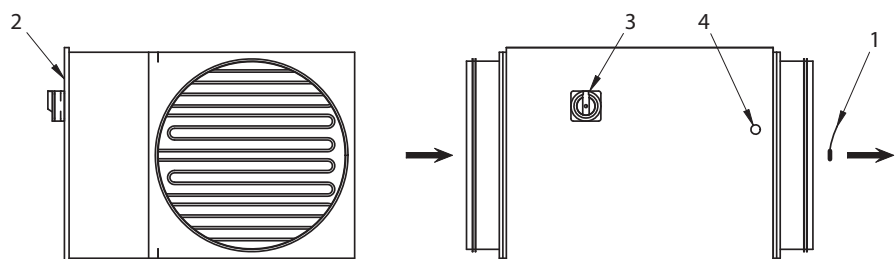

RD12573-01

Pos. no.	Part	Function
1	Temperature sensor	Measures the temperature in the supply air duct
2	Connection box	Connection box for connecting the heating coil to the VEX unit control system and power supply
3	Isolation switch	Isolation switch used for servicing
4	Reset	Manual reset

### 1.3 Principal dimensions

#### VEX240 heating coil HCE240HK

The following drawing gives the principal dimensions:

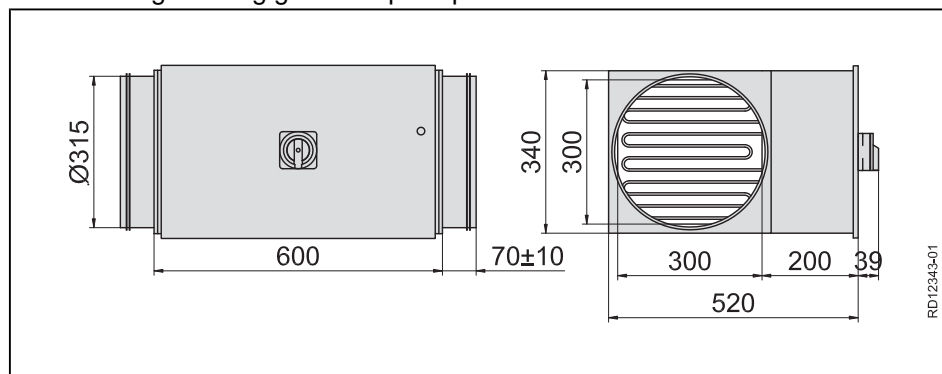

RD12343-01



## 2. Mechanical assembly

### 2.1 Unpacking

**Supplied components**

The following components are supplied:

- Electric heating coil with integral connection box.

**2.1.1 Weight, 240HCE**

Heating coil weighs 23 kg

### 2.2 Position in relation to VEX

**2.2.1 Left/Right positioning**

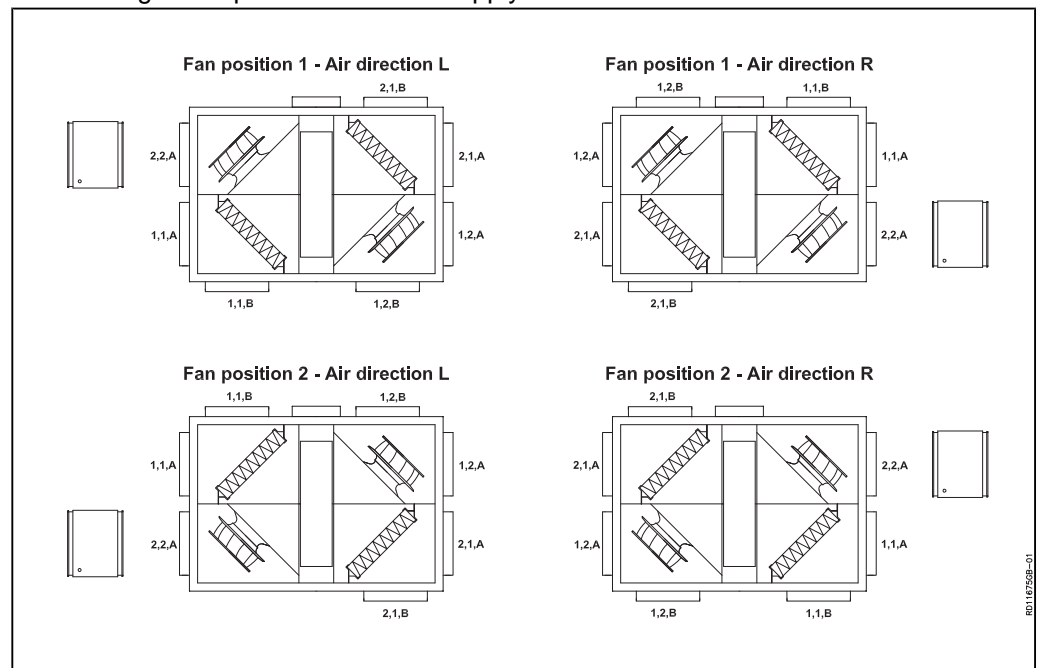

The heating coil is positioned on the supply air duct as shown below:

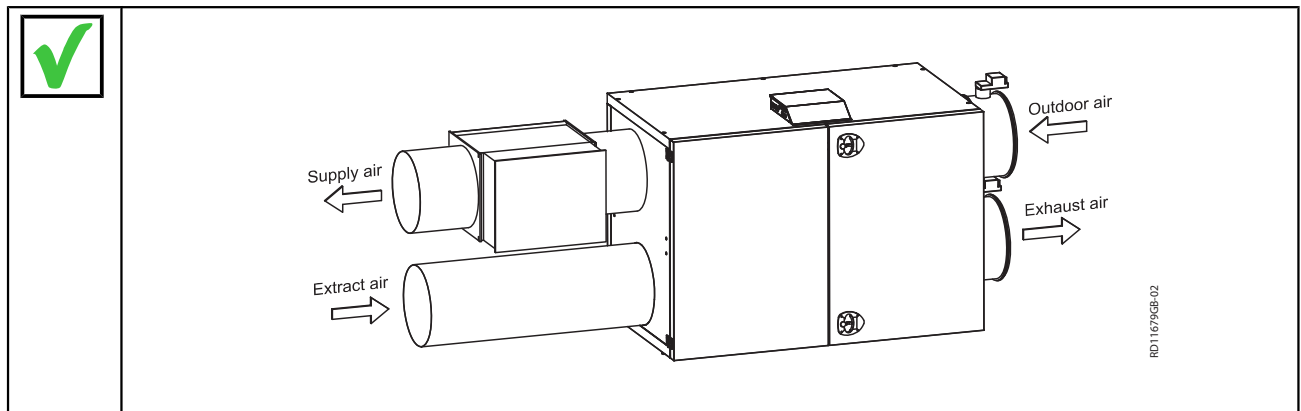

**2.2.2 Correct installation on the duct system**

Position the heating coil on the supply air duct or directly on the ventilation unit supply air spigot.

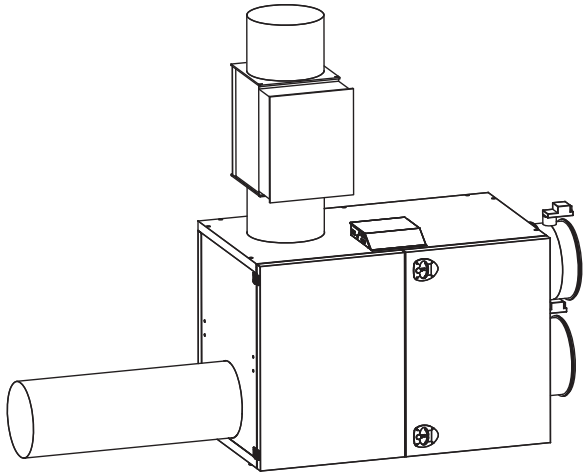

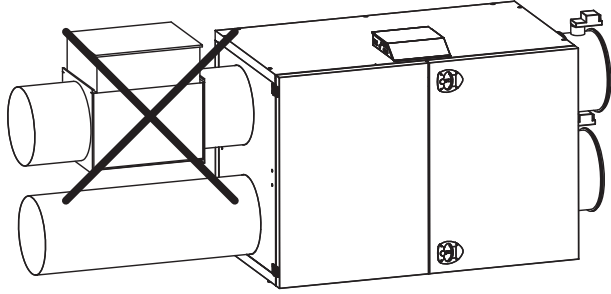

The heating coil must always be supported - during fitting as well (The fixture for this is not part of the EXHAUSTO delivery).



The heating coil must always be positioned so that

- air flows through it horizontally or
- air flows through it vertically upwards



Take note of the air direction (see the air-direction arrow on the heating coil door)

### 2.2.3 Location of TE-HCE-SUPPLY

The temperature sensor is positioned here

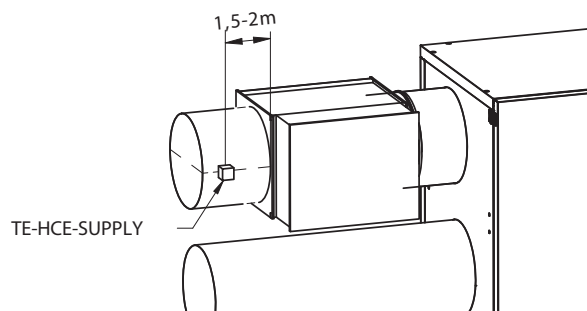



### 3. Electrical installation

#### 3.1 Connection diagram

Diagram

The diagram below illustrates the connection of the supply current and the heating coil connection box.

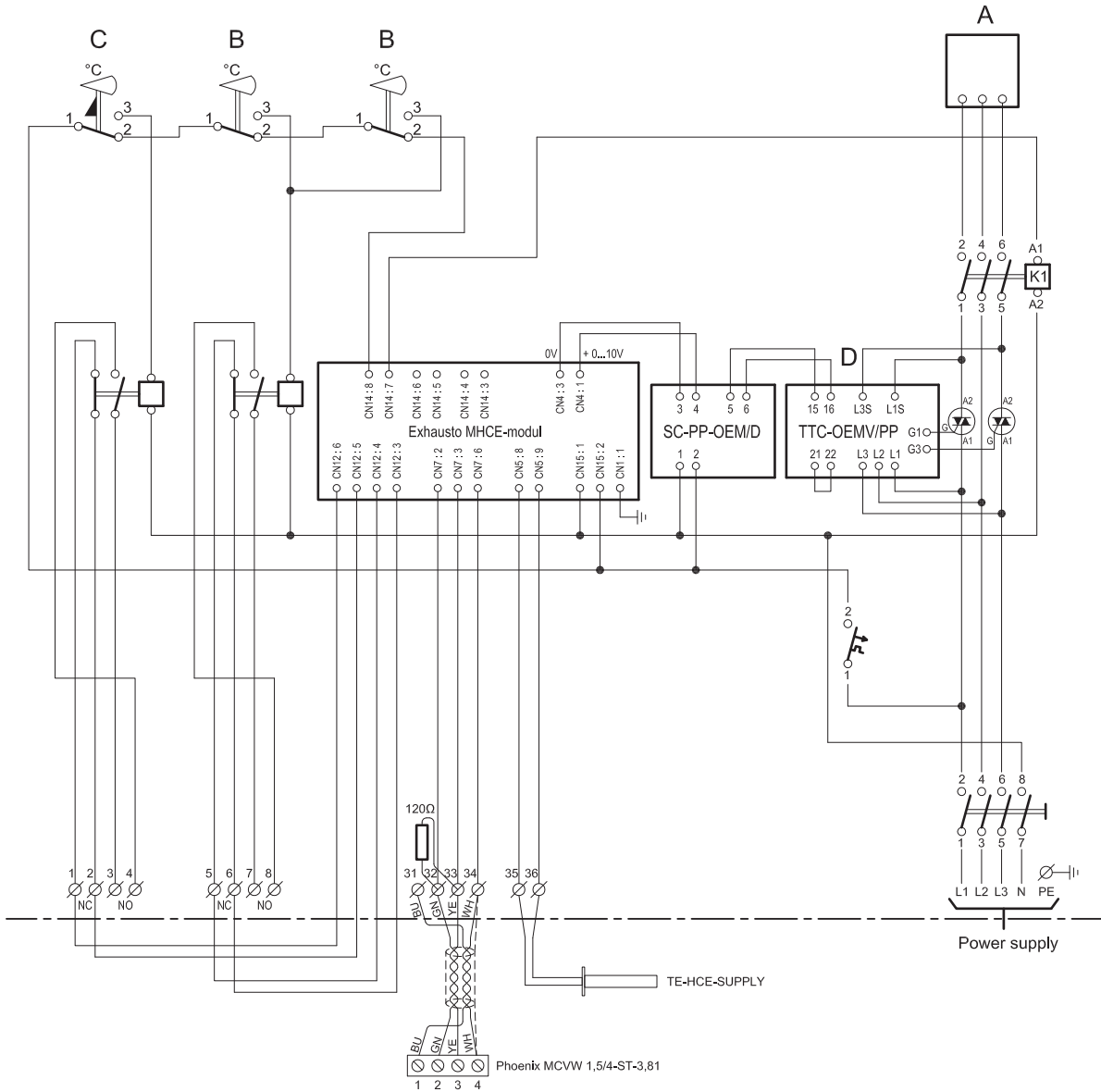

RD1255-02

Diagram data

Output [kW]	Power Supply	Max. phase current (A)	Max. short-circuit current (Icu)
6	3 x 400V + N+ PE	8,7	10 kA in accordance with EN60947.2

Key to diagram

Designation	Component
A	Heating element
B	Overheating protection with automatic reset, TSA70 (qty. 2)
C	Overheating protection with manual reset, TSA120
D	Triac regulation of heating element

3.2 Connection of Modbus devices

3.2.1 Connection of Modbus devices

Diagram

Connection must be carried out according to the following diagram (see also instructions "Electrical Installation Guide for VEX with EXact control" for the VEX unit in question. This shows the method for connecting standard components on the connection box connection diagram.

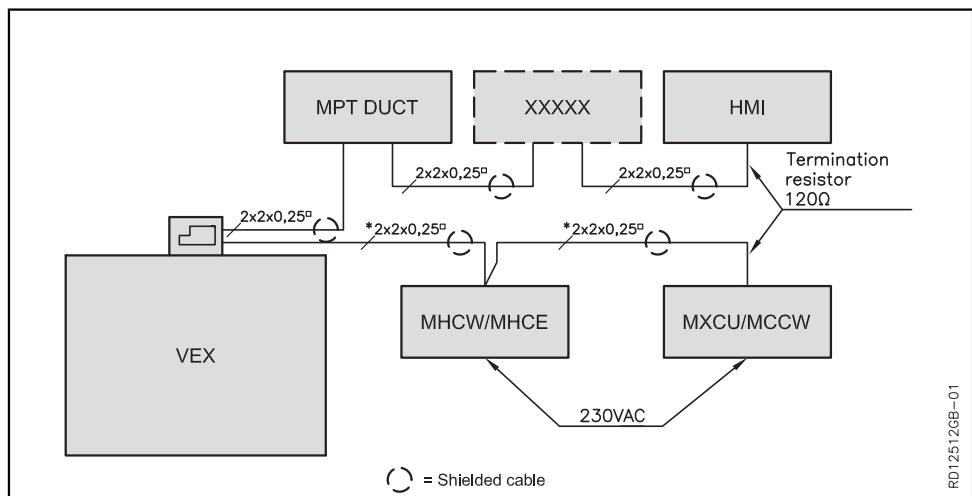

\* Not supplied by EXHAUSTO

MHCW/MHCE	Heat control (water or electric)
MXCU/MCCW	Cooling control
MPTDUCT	Pressure measurement in duct
XXXXX	Can be different modules, e.g. MIO module or additional MPTDUCT
HMI	Control panel

RD12512GB-01



### 3.2.2 Cable (type, max. length and termination)

**Cable**

EXHAUSTO recommends the use of 4-core, twisted pair, shielded cable. To limit voltage drop across the cable, 0.25<sup>2</sup> conductors are recommended. For correct connection of shielded cable to Modbus units, refer to the "Electrical Installation Guide" for the relevant VEX.

**Max. cable length**

The overall cable length of a complete installation may not exceed 200 m.

**Modbus, termination or daisy chaining**

It is necessary to terminate the first and last devices on the bus with a 120 Ω resistor - see below. VEX is supplied with two resistors, which are included in the drawings wallet on the door.

If	Then	See diagram no.
MHCE is the first or last device on the bus	it must be terminated with a 120 Ω resistor.	1
MHCE is <b>neither</b> the first nor last device on the bus	it must be daisy-chained to the next device	2

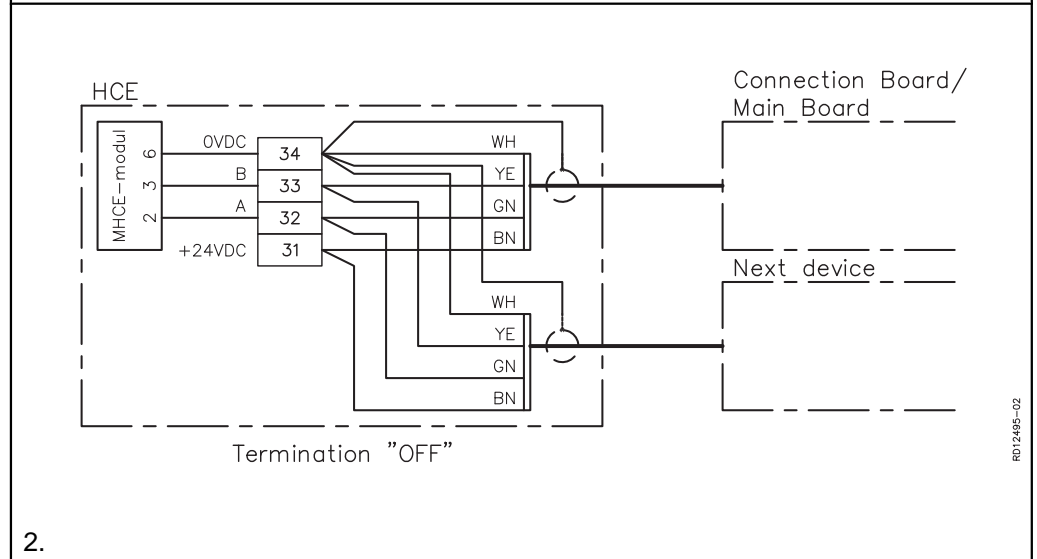
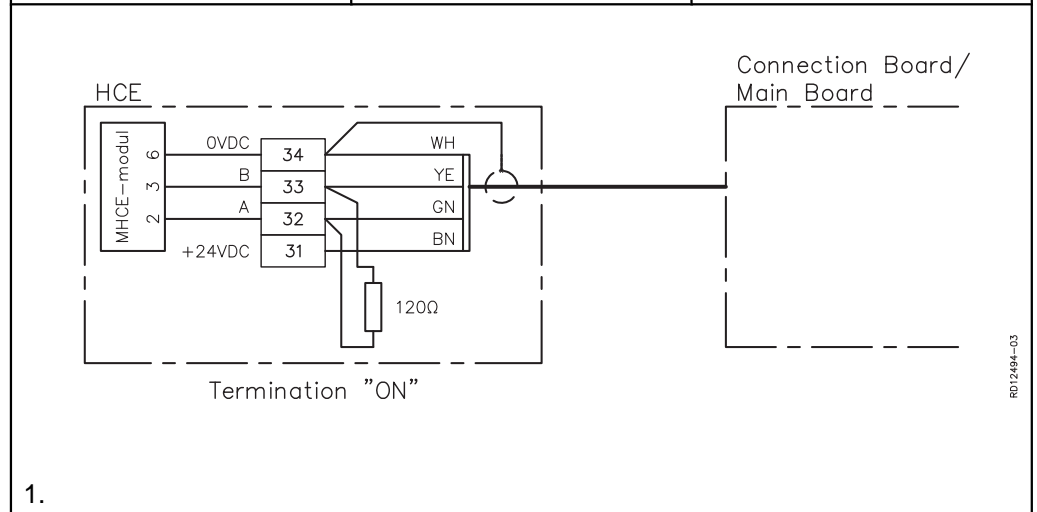



## 4. Commissioning and operation

### 4.1 Warnings, commissioning

#### 4.1.1 Warnings, overheating



Supply airflow must not fall below 486 m<sup>3</sup>/h (135 l/s) when operating with the electric heating coil - this is to avoid overheating.

#### Warnings



During commissioning, it may be necessary to work with the control system boxes open. Use only electrically-insulated tools.



Do not touch the heating coil - risk of burns.

#### NB!

Fans have a run-on time of 5 minutes (control signal to fans cuts out after 3 minutes) to ensure sufficient cooling of the electric heating coil after device shut-down.

- At airflows between 486 m<sup>3</sup>/h and 162 m<sup>3</sup>/h, operation proceeds with reduced heat output, and it may not be possible to maintain the desired supply air temperature.

### 4.2 Safety features

#### 4.2.1 Safety features

##### Power ramp limiting

- Power ramping is limited to max. 25% per minute.
- Power is removed without ramping.
- Ramping can cause heating power levels to be read as higher than they actually are.

##### Heating coil thermal cut-out

The heating coil is protected against overheating by 4 thermal fuses:

- 2 x TSA70, located in the air current. This trips at 70 °C and has an automatic reset.
- 1 x TSA60, located in the PCB. This trips at 60 °C and has a manual reset on the HMI panel.
- 1 x TSA120, located in the airflow. This trips at 120 °C (measured at heating coil) and has manual reset on the HMI panel (both HMI and MHCE must be reset).

##### Communication monitoring

If communication between the MHCE2 and the EXact2 control system fails, the power output is reset and an alarm is tripped.

##### Alarms

If heating is required, and airflow does not exceed 162 m<sup>3</sup>/h (45 l/s), an alarm is tripped.

For more information about alarms refer to the "EXact2 Control System Basic Instructions for the VEX200 series".

### 4.3 Maintenance and alarms

**Maintenance**

See "Maintenance" section in the product instructions for the VEX unit.

**Alarms**

See "Alarms" section in the "EXact2 Control System Basic Instructions for VEX".



## 5. Technical specifications

### 5.1 Electric heating coil

#### Electric heating coil

<b>Weight</b>	Heating coil HCE, weight	23 kg
<b>Data</b>	Total power rating	6 kW
	Supply voltage to connection box	3 x 400 V + N + PE, 50 Hz
	Thermal fuse, (control system), TSA60	60 °C
	Thermal fuse, TSA70	70 °C
	Thermal fuse, TSA120	120 °C
	Temperature tolerance	±5 K
	Temperature drop before reconnection possible	15 K

#### Diagram

The diagram below can be used to determine the air temperature increase at a given airflow and electric heating coil size.

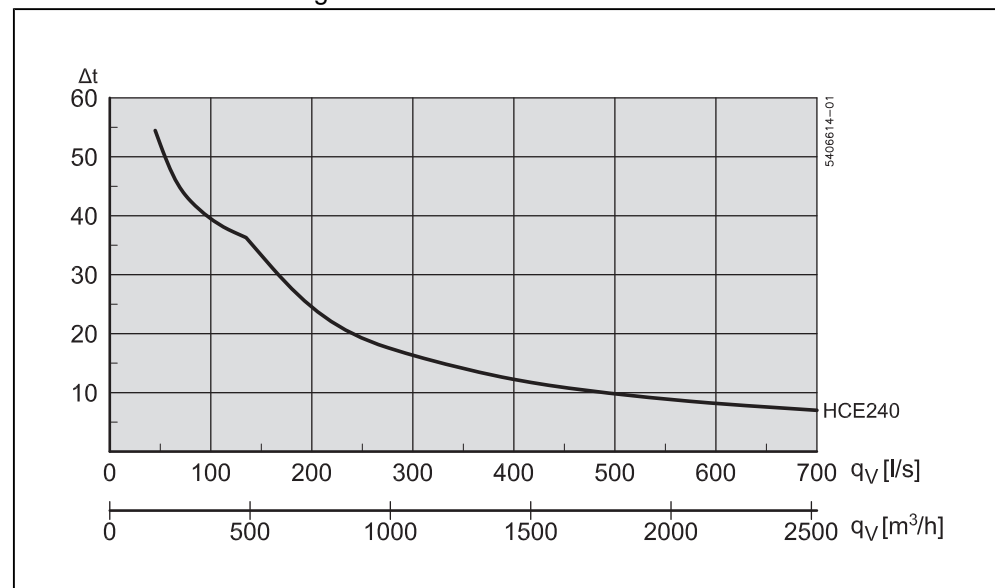

#### Pressure drop across electric heating coil

See capacity diagram in "Technical Data" section of the VEX product instructions.

### 5.2 Spare parts

#### Production part number

When ordering spares, please state the relevant production part number. This will ensure that the correct parts are delivered. The production number is given on the front of the VEX guidelines and on the VEX rating plate.

**Spare parts list**

The following parts are stocked as spares for the coil.

Spare parts
Electric heating control system, MHCE module







Scan code and go to addresses at  
[www.exhausto.com](http://www.exhausto.com)