





GB

HCE electrical heating coil for VEX240HX for third-party control systems



-  Product information.....Chapter 1 + 6
-  Mechanical assembly.....Chapter 2
-  Electrical installation.....Chapter 3
-  Commissioning and operation.....Chapter 4
-  Maintenance.....Chapter 5

Original instructions



1. Product information

1.1. Application.....3
 1.1.1. Application.....3
1.2. Description.....3
 1.2.1. Construction of the heating coil.....3
1.3. Principal dimensions.....3



2. Mechanical assembly

2.1. Unpacking.....5
 2.1.1. Weight, 240HCE.....5
2.2. Position in relation to VEX.....5
 2.2.1. Left/Right positioning.....5
 2.2.2. Correct installation on the duct system.....5
 2.2.3. Correct installation on the duct system.....6
 2.2.4. Location of TE-HCE-SUPPLY.....7



3. Electrical installation

3.1. Connection diagram.....8
 3.1.1. Connection diagram.....8



4. Commissioning and operation

4.1. Warnings, commissioning.....9
 4.1.1. Warnings, overheating.....9
4.2. Safety features.....9
 4.2.1. Safety features.....9



5. Maintenance

5.1. Maintenance.....10



6. Technical specifications

6.1. Heating coil.....11



1. Product information

1.1 Application

1.1.1 Application

The EXHAUSTO VEX200 HCE heating coil is an accessory to the VEX200 range and is used to increase the temperature of the supply air.

Designations used in these instructions

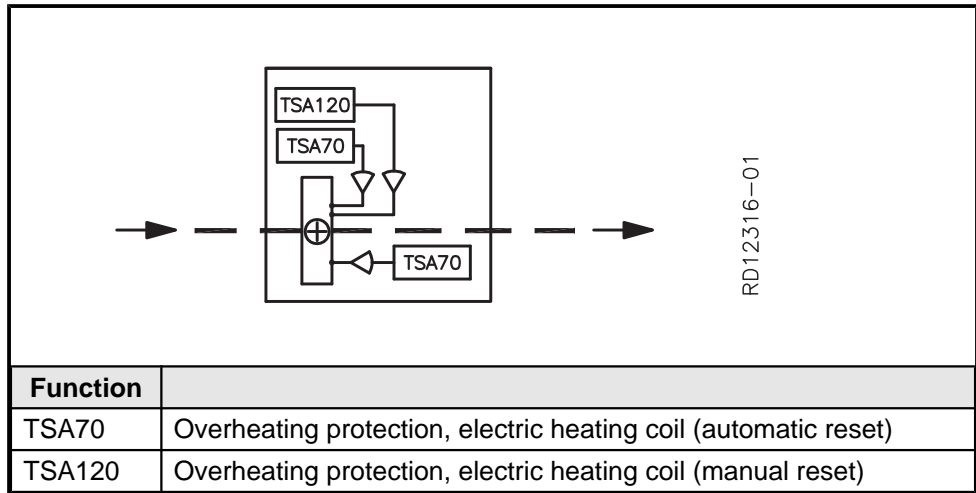

For more information about resetting thermal cut-outs, see section "Safety features".

1.2 Description

1.2.1 Construction of the heating coil

General drawing

The drawing below shows the construction of the heating coil:

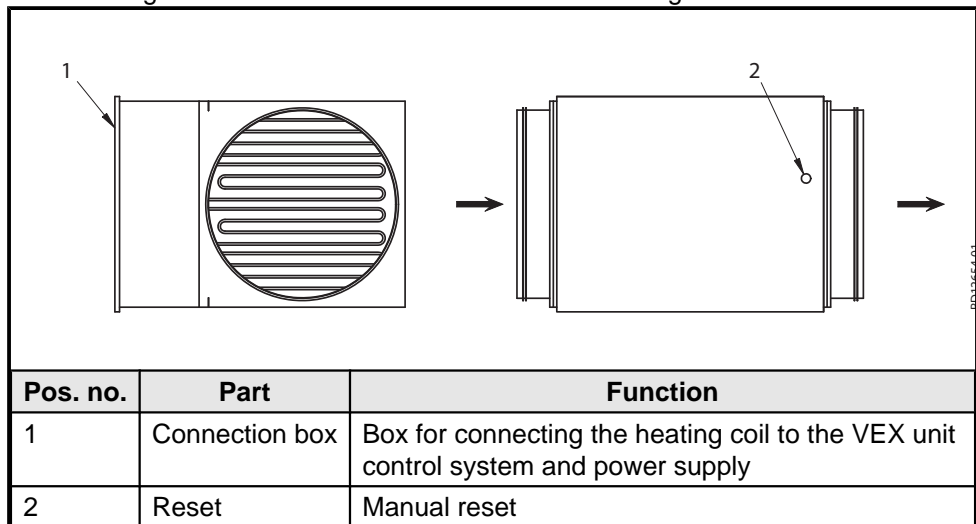

1.3 Principal dimensions

VEX240 heating coil
HCE240HKX

The following drawing gives the principal dimensions:

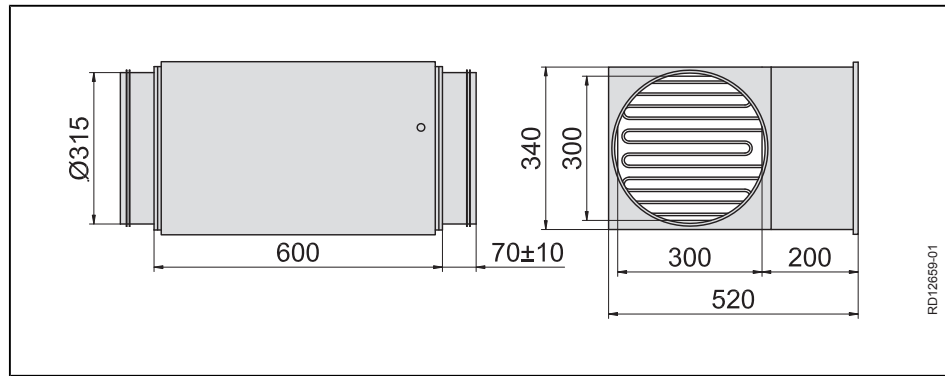



2. Mechanical assembly

2.1 Unpacking

Supplied components

The following components are supplied:

- Heating coil

2.1.1 Weight, 240HCE

Heating coil weighs 23 kg

2.2 Position in relation to VEX

2.2.1 Left/Right positioning

The heating coil is positioned on the supply air duct as shown below:

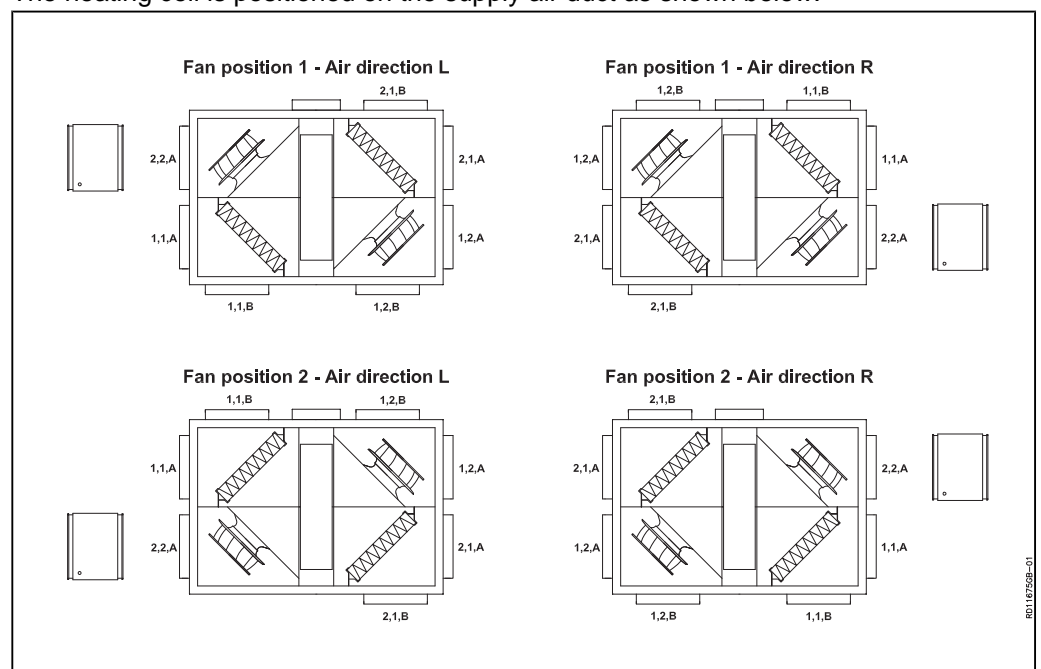





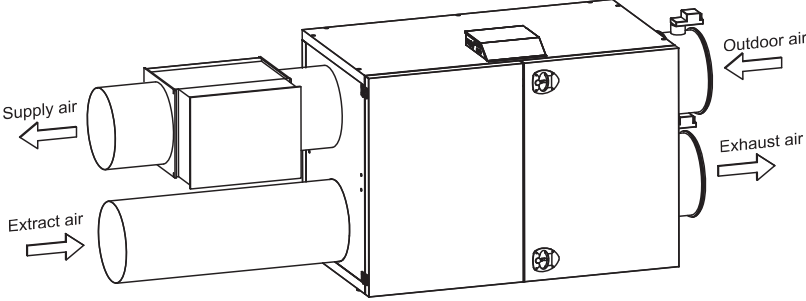

2.2.2 Correct installation on the duct system

Position the heating coil on the supply air duct or directly on the ventilation unit supply air spigot.

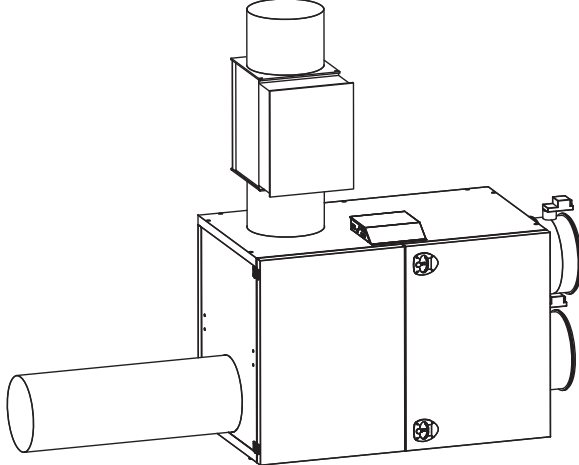
2.2.3 Correct installation on the duct system

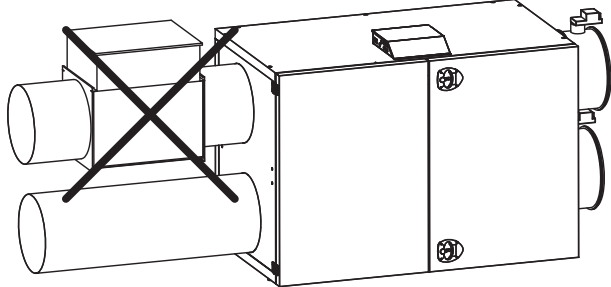
Position the heating coil on the supply air duct or directly on the ventilation unit supply air spigot.

	 <p style="text-align: right; font-size: small;">RD11679GB-02</p>
	 <p style="text-align: right; font-size: small;">RD12653-01</p>
	 <p style="text-align: right; font-size: small;">RD11680-02</p>

- 

The heating coil must always be supported - during fitting as well (The fixture for this is not part of the EXHAUSTO delivery).
- 

The heating coil must always be positioned so that

 - air flows through it horizontally or
 - air flows through it vertically upwards
- 

Take note of the air direction (see the air-direction arrow on the heating coil door)

2.2.4 Location of TE-HCE-SUPPLY

The temperature sensor is positioned here

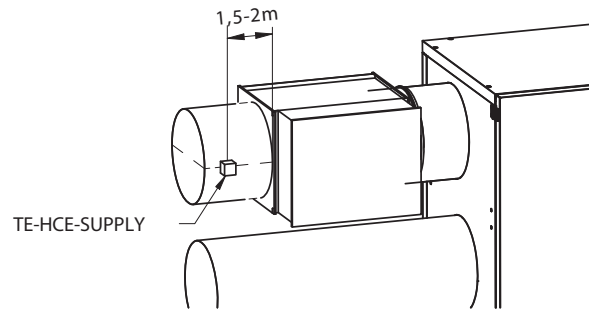



3. Electrical installation

3.1 Connection diagram

3.1.1 Connection diagram

Diagram

The diagram below illustrates the connection of the supply voltage and the heating coil connection box.

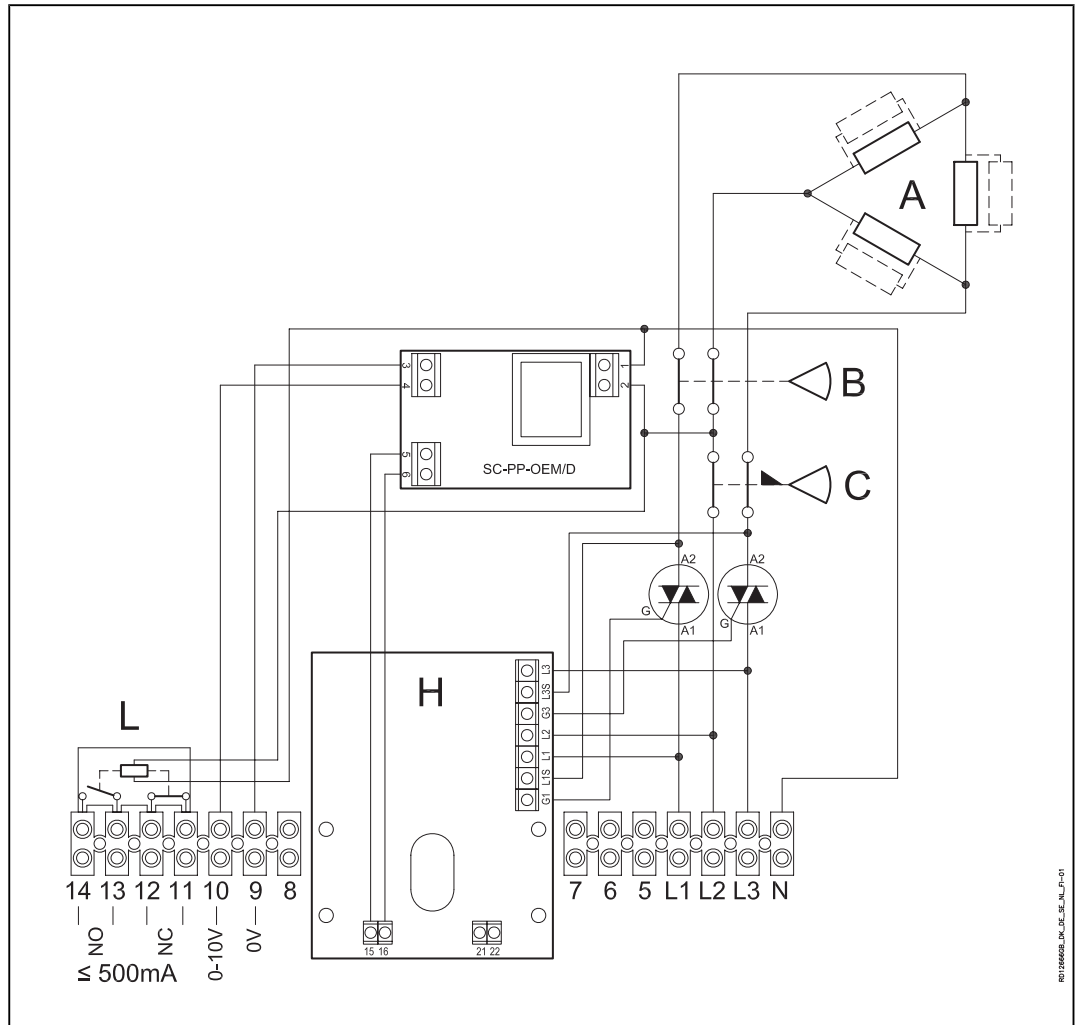

Key to diagram

Designation	Component
A	Heating elements
B	Overheating protection with automatic reset, TSA70 (qty. 2)
C	Overheating protection with manual reset, TSA120
L	Alarm relay
H	Thyristor



4. Commissioning and operation

4.1 Warnings, commissioning

Warnings



During commissioning, it may be necessary to work with the control system boxes open. Use only electrically-insulated tools.



Do not touch the heating coil - risk of burns.

NB!

The ventilators must run on for 3 minutes.

4.1.1 Warnings, overheating



Supply airflow must not fall below 486 m³/h (135 l/s) when operating with the electric heating coil - this is to avoid overheating.

4.2 Safety features

4.2.1 Safety features

Heating coil thermal cut-out

The heating coil is protected against overheating by 3 thermal fuses:

- 2 x TSA70, which trip at 70°C and have automatic reset.
- 1 x TSA120, that trips at 120°C (measured at heating coil) and has manual reset.



5. Maintenance

5.1 Maintenance

Maintenance See section "Maintenance" in the product instructions for the VEX unit.



6. Technical specifications

6.1 Heating coil

Electric heating coil

Weight	HCE heating coil, weight	23 kg
Data	Total power rating	6 kW
	Supply voltage to connection box	3 x 400 V + N + PE, 50 Hz
	Thermal fuse, TSA70	70°C
	Thermal fuse, TSA120	120°C
	Temperature tolerance	±5 K
	Temperature drop before reconnection possible	15 K

Diagram

The diagram below can be used to determine the air temperature increase at a given airflow and electric heating coil size.

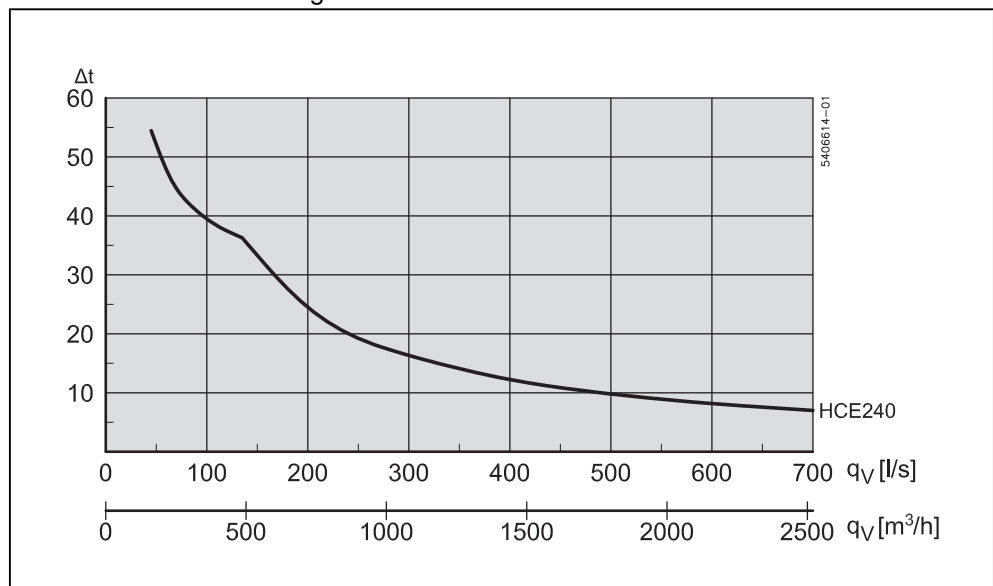

Pressure drop across electric heating coil

See capacity diagram in "Technical Data" section of the VEX product instructions.



Scan code and go to addresses at
www.exhausto.com