

GB

VEX150CF Horizontal HCE

with EXact2 control

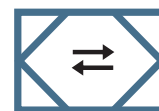

VEX100CF
RANGE
COUNTER FLOW
HEAT EXCHANGER



Unit supplied with (factory fitted):





- Electric heating coil HCE150 - 12,0kW
- Electric heating coil HCE150 - 18,0kW
- VDI 6022
- M5-compact filter, FP
- F7-compact filter, FP
- OD - roof for outdoor

The following accessories are supplied separately:

- ___ pieces, control panel, HMI
- Closing damper, LS400-24, (LSA exhaust)
- Closing damper, LS400-24, (LSF outdoor)
- Closing damper, LSR400-24, with spring-return (LSAR exhaust)
- Closing damper, LSR400-24, with spring-return (LSFR for outdoor)
- ___ pieces, Fire thermostat, BT40
- ___ pieces, Fire thermostat, BT50
- ___ pieces, Fire thermostat, BT70
- ___ pieces, Constant pressure control, MPT-DUCT
- Motion sensor, MIO-PIR
- Humidity sensor, MIO-RH
- CO₂-sensor, MIO-CO₂-DUCT
- CO₂-sensor, MIO-CO₂-ROOM
- Temperature sensor, MIO-TS-DUCT
- Temperature sensor, MIO-TS-ROOM
- Control for external cooling unit, MXCU
- Mounting base, MSV150H
- TS-RPT-X
- _____

Prod.order no.: _____

Sales order no.: _____

-  Product information..... Chapter 1 + 6
-  Mechanical assembly..... Chapter 2 + 3
-  Electrical installation..... Chapter 4
-  Maintenance..... Chapter 5

Original brugsanvisning



1. Product information

1.1. Designations used in these instructions.....	6
1.1.1. Simplified diagram.....	6
1.2. Application.....	7
1.3. Location requirements.....	7
1.3.1. Space requirements.....	7
1.3.2. Requirements for underlying surface.....	7
1.3.3. Condensation outlet.....	7
1.3.4. Requirements for duct system.....	8
1.4. Description.....	9
1.4.1. VEX unit construction.....	9
1.4.2. Parts of the VEX unit.....	10
1.5. Principal dimensions.....	11



2. Handling

2.1. Unpacking.....	13
2.2. Transport.....	13
2.2.1. Passage through openings.....	14
2.2.2. Internal transport with reduced weight.....	15



3. Mechanical assembly

3.1. Installation.....	17
3.1.1. Installation directly on floor.....	17
3.1.2. Installation on mounting base.....	17
3.2. Condensation outlet.....	17
3.2.1. Establishment of condensation outlet.....	17



4. Electrical installation

4.1. Electrical installation.....	19
--	-----------



5. Maintenance, hygiene and servicing

5.1. Operating readings via the HMI panel.....	20
5.2. Maintenance.....	20
5.2.1. Overview of maintenance intervals.....	20
5.3. Hygiene (VEX100VDI only).....	21
5.4. Servicing and cleaning.....	21
5.4.1. Filter change.....	21
5.4.2. Cleaning the fans.....	21
5.4.3. Cleaning the heating coils.....	22
5.4.4. Removing and cleaning the counterflow heat exchanger.....	22
5.4.5. Cleaning the counterflow heat exchanger.....	22





6. Technical data

6.1. Weight, corrosion class, temperature ranges, etc.....	24
6.2. Compact filters.....	26
6.3. Electric heating coil	27
6.4. Capacity diagram.....	28
6.5. Ordering spare parts.....	28

6.6. Environmental declaration.....29

Symbols, terms and warnings

Prohibition symbol		Failure to observe instructions marked with a prohibition symbol may result in serious or fatal injury.
Danger symbol		Failure to observe instructions marked with a danger symbol may result in personal injury and/or damage to the unit.
Scope	<p>This instruction manual is for use with EXHAUSTO VEX-type air handling units. Please refer to the product instructions regarding accessories and extra equipment.</p> <p>The instructions must be fully observed to ensure personal safety and to protect the equipment and ensure its correct operation. EXHAUSTO A/S accepts no liability for accidents caused by equipment not used in accordance with the manual's instructions and recommendations.</p>	
Supply air/extract air	<p>This instruction manual uses the following terminology:</p> <ul style="list-style-type: none"> • Supply air (air blown in) • Extract air (air removed) • Outdoor air • Exhaust air 	
Front page: Accessories	<p>The front page of the instruction manual contains a checklist, detailing the accessories delivered with the VEX unit.</p>	
NB	When retrofitting EXHAUSTO accessories, please update the checklist on the front page.	
Definition	<p>In the type designation <u>R</u> stands for Right, indicating that the supply air is to the right of the unit, as seen from the operating side. Supply air to the left is designated with <u>L</u> for Left</p>	

Warnings

Opening the air handling unit



Do not open the service doors until power has been disconnected at the isolation switch and the fans have stopped.

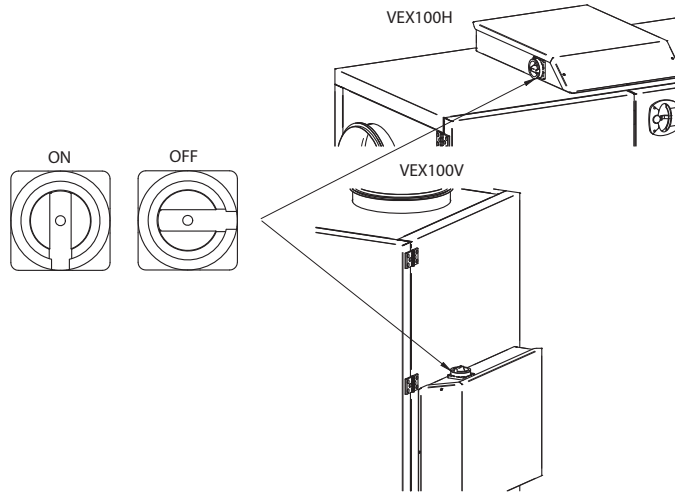

RD13318-01

No duct connection



If one or more of the spigots is not connected to a duct: fit a protective net to the spigots with a maximum mesh size of 20 mm.

Lock the air handling unit during operation

The VEX unit must always be locked during operation:

- Use the cylinder lock in the handle. **Remember** to remove the key from the lock.
- Or use a padlock. Use the handle's built-in padlock fixture.

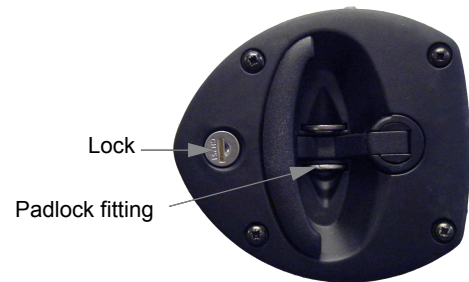

Information plate

The VEX unit rating plate shows:

- VEX unit, type (1)
- production number (2)

EXHAUSTO		CE	
Type	V150CFHLECW2	← Icu = 10kA	1
	No./Year	2406294/2017	← 2
Supply	Voltage:	3x400V+N+PE ~50Hz	Current:
			15A
Heat	HCW		
FAN ECO design	η = 60,0 % (A) N62 (2015) N = 74.4 VSD integrated		

NB:

Always have the production number ready when contacting EXHAUSTO A/S.



1. Product information

1.1 Designations used in these instructions

1.1.1 Simplified diagram

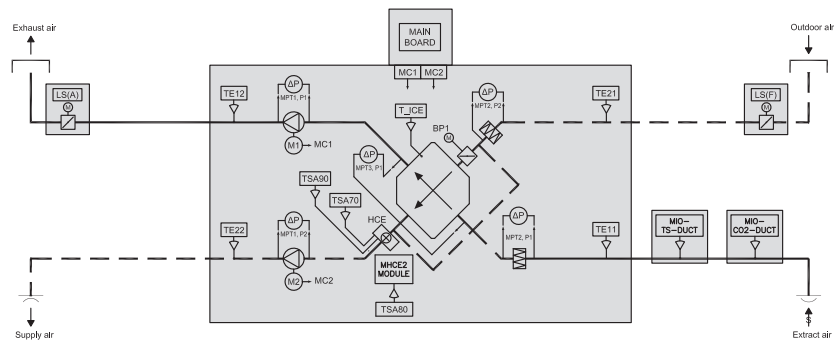

Component	Function	Standard/accessory
HCE	Electric heating coil	Standard
TSA70	Overheating protection, electric heating coil (automatic reset)	Standard
TSA80	Overheating protection, electric heating control (manual reset via HMI)	Standard
TSA90	Overheating protection, electric heating control (manual reset via HMI)	Standard
MPT1, P1	Airflow control, extract air	Accessories
MPT1, P2	Airflow control, supply air	Accessories
MPT2, P1	Filter monitor, extract air	Accessories
MPT2, P2	Filter monitor, outdoor air	Accessories
MPT3, P1	Ice detection	Accessories
LS(F)/LS(F)R	Closing damper, outdoor air	Accessories
LS(A)/LS(A)R	Closing damper, exhaust air	Accessories
BP1	Bypass damper	Standard
M1	Extract air motor	Standard
M2	Supply air motor	Standard
MC1	Motor controller, motor 1	Standard
MC2	Motor controller, motor 2	Standard
Main board	Control system	Standard
TE11	Temperature sensor, extract air	Standard
TE12	Temperature sensor, exhaust air	Standard
TE21	Temperature sensor, outdoor air	Standard
TE22	Temperature sensor, supply air	Standard
T _{ice}	Temperature sensor for ice in exchanger	Standard

1.2 Application

Comfort ventilation EXHAUSTO VEX is used for comfort ventilation tasks.
Operating temperature range for the unit – see section "Technical data".

Prohibited uses The VEX unit is not to be used to transport solid particles or in areas where there is a risk of explosive gases.

1.3 Location requirements

Positioning The unit is designed for indoor fitting. The unit can be ordered for outdoor fitting, in which case it is provided with a roof (accessory VEX100OD).

1.3.1 Space requirements

The drawing below indicates how much space is needed for opening the doors and servicing the unit, e.g. changing filters, cleaning, servicing, etc.

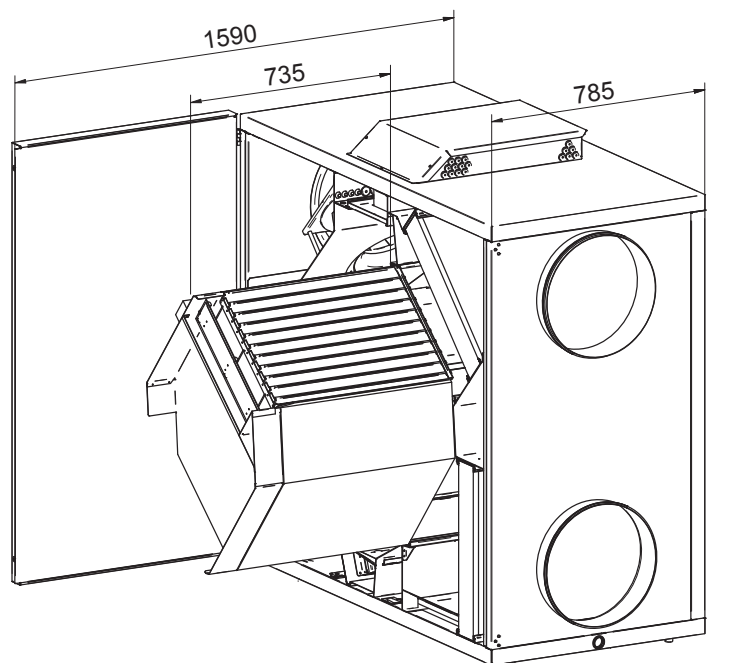

NB: For servicing, the VEX must have a free height of at least 300 mm above the connection box.

1.3.2 Requirements for underlying surface

When fitting the unit directly to an existing surface - i.e. without using the mounting base (accessory) - the surface must be:

- flat
- level (+/- 3 mm per metre)
- hard
- resistant to vibration

1.3.3 Condensation outlet

A condensation outlet must be installed in the immediate vicinity of the unit. See also "Mechanical assembly" section.

1.3.4 Requirements for duct system

Silencers

The duct system must be fitted with silencers specified by the Project Manager, which meet the requirements of the operating area.

Bends

A duct bend may be fitted immediately after the unit, because the airflow in the spigot has a uniformly moderate speed profile, which results in negligible system pressure loss.

Insulation

The duct system must be insulated against:

- condensation
- sound leakage
- heating/cooling losses

Condensation

Condensation in the ducts may occur when the exhaust/outdoor air has high humidity. EXHAUSTO recommends a condensation outlet is also fitted at the lowest point in the ducts.

Outdoor air intake

The outdoor air intake must be dimensioned with sufficiently low airflow to prevent rain and snow being drawn into the duct system.

No duct connection

If one or more of the spigots is not connected to a duct: Fit a protective net to the spigots with a maximum mesh width of 20 mm.

1.4 Description

1.4.1 VEX unit construction

The following drawings show an overview of the construction of left and right-hand models of VEX units (shown without doors).

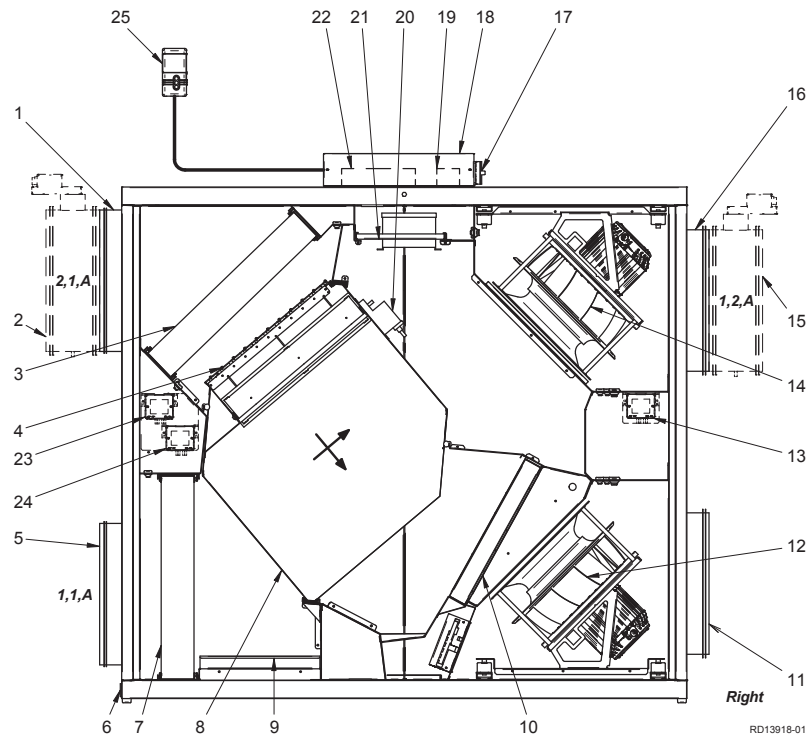
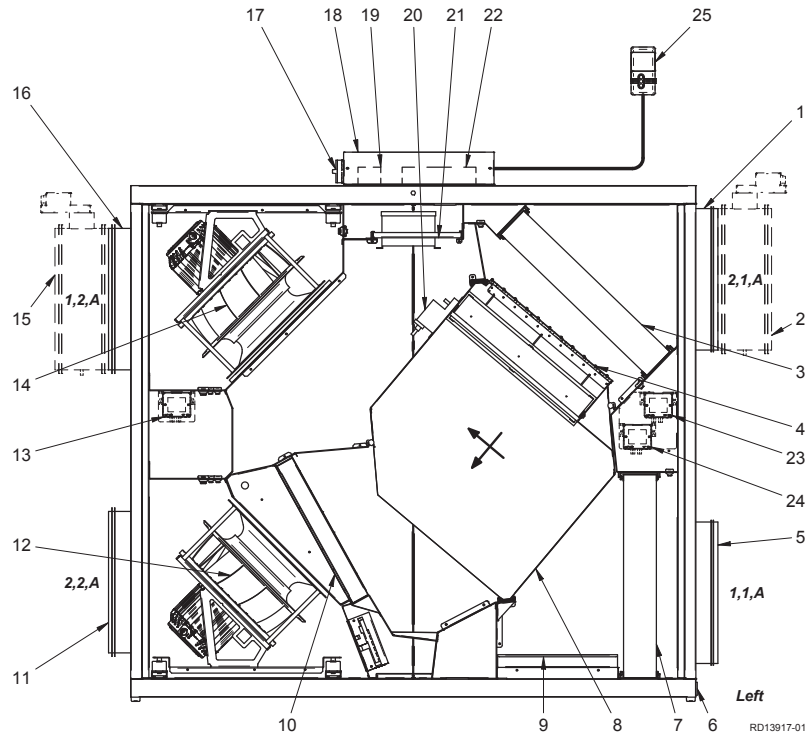

Pos.	Part	Function
1	Spigot 2.1.A	Outdoor air spigot The spigot can also be positioned on the top of the air handling unit (2.1.B)
2	Closing damper LS	Closing damper, outdoor air, LSF (accessory).
3	Outdoor air filter	Filters outdoor air.
4	Bypass damper	For operation with heat recovery, the bypass damper is closed so that the air passes through the counterflow heat exchanger. For bypass operation, the damper is open, and the air bypasses the heat exchanger.
5	Spigot 1,1,A	Extract air spigot
6	Condensation outlet	Channels condensate to the drain.
7	Extract air filter	Filters extract air.
8	Counterflow heat exchanger	Conducts heat from extract air to supply air.
9	Condensation tray	Collects the condensate and drains it away from the counterflow heat exchanger to the condensation outlet
10	Electric heating coil	Heats supply air if heat recovery is insufficient.
11	Spigot, 2,2,A	Supply air spigot. The spigot can also be positioned at the bottom of the air handling unit (2.2.B).
12	Supply air fan	For outdoor air/supply air.
13	MPT1	Airflow control (accessory).
14	Extract air fan	For exhaust/extract air.
15	Closing damper LS	Closing damper, exhaust air, LSA (accessory).
16	Spigot 1,2,A	Extract air spigot The spigot can also be positioned on the top of the unit (1.2.B).
17	Isolation switch	Connects/disconnects current.
18	Connection box	Connection of accessories.
19	Terminal row	Connection of accessories to ventilation unit.
20	Bypass motor	Opens/closes bypass damper.
21	Extraction plate	Positioning of motor control components.
22	EXact2 control	Control system.
23	MPT3 (DEP)	Ice detection (accessory).
24	MPT2 (MPTF)	Filter monitor (accessory).
25	HMI panel	Control panel.

1.4.2 Parts of the VEX unit

Cabinet The inside and outside of the cabinet is made of Aluzinc® (DC TRANSLATED) Kabinettet er isoleret med 50 mm mineraluld.

Fans The unit contains two centrifugal fans with backward curved blades for extract air and supply air.

Counterflow heat exchanger The counterflow heat exchanger in the unit is mounted with a modulating bypass damper. The counterflow heat exchanger can be removed and cleaned.

Filters The unit includes integral compact filters for both extract air and supply air.

1.5 Principal dimensions

VEX150H, Left

The following drawing gives the principal dimensions:

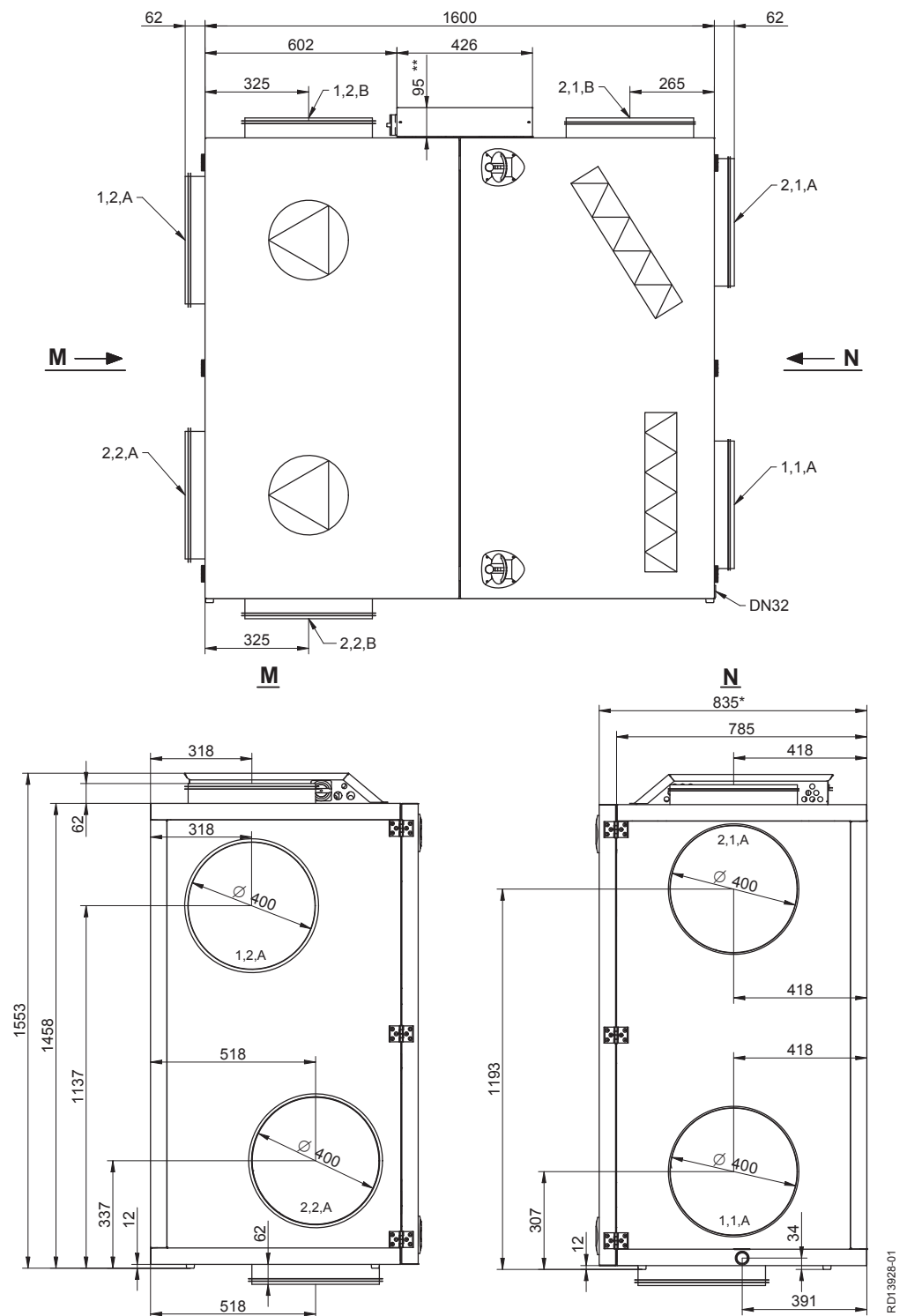

NB:

The drawing shows all of the spigot positioning options.

* Allow a distance for service in front of the unit equivalent to the unit depth.

** Allow a min. of 300 mm free height for service.

VEX150H, Right

The following drawing gives the principal dimensions:

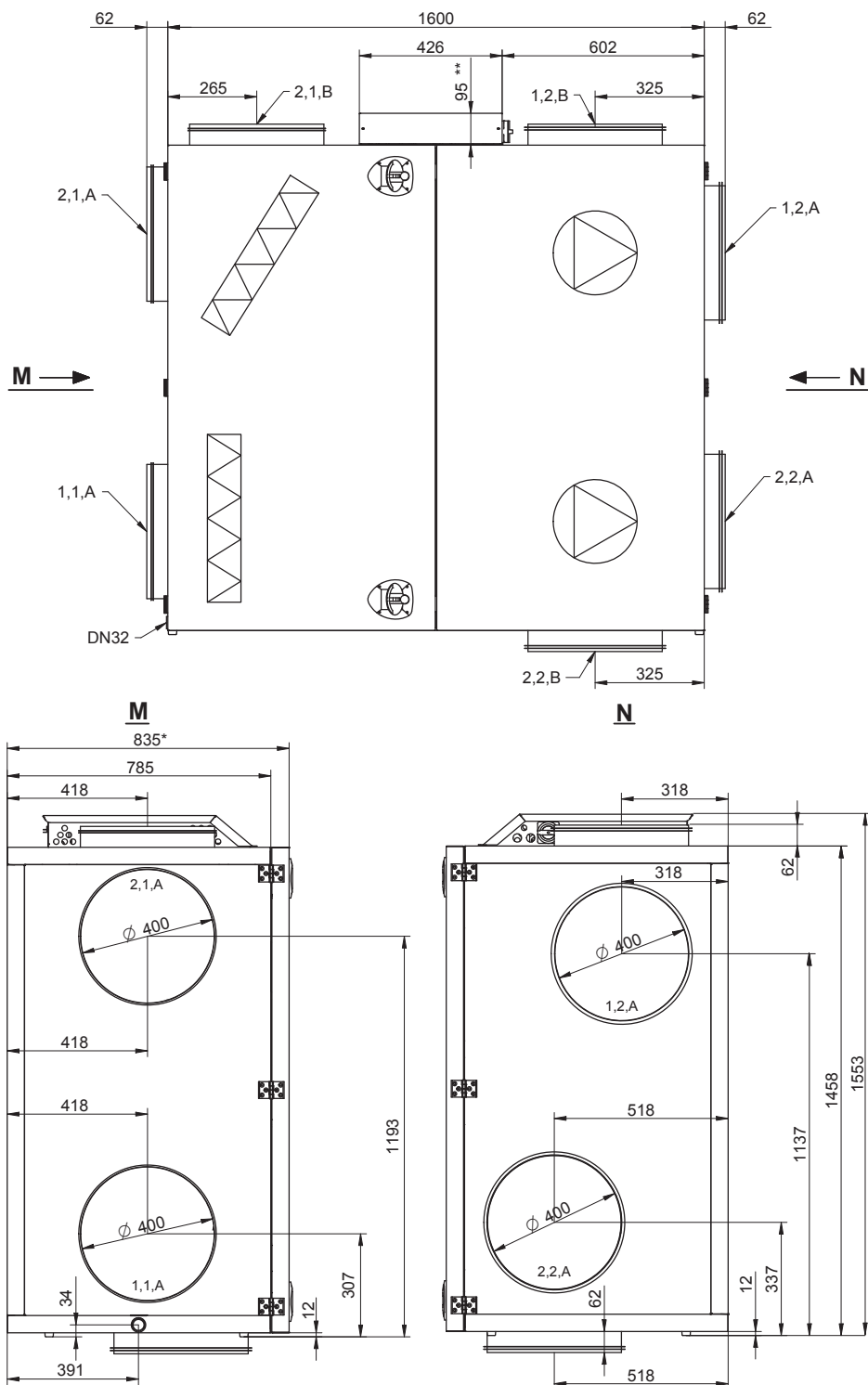

NB:

The drawing shows all of the spigot positioning options.
 * Allow a distance for service in front of the unit equivalent to the unit depth.
 ** Allow a min. of 300 mm free height for service.

RD13529-01



2. Handling

2.1 Unpacking

Supplied components

The following components are supplied:

- VEX unit
- Supplied accessories (as indicated in the checklist on the front page of the instructions).

Packaging

The unit is delivered on a disposable pallet and packed in clear plastic.

NB

Once the plastic has been removed, the unit must be protected against dirt and dust:

- **The covers on the spigots must not be removed until the spigots are connected to the ventilation ducts.**
- **Whenever possible, keep the unit closed during fitting.**

The unit should be cleaned before it is used.

Once the VEX unit is fitted, it must be checked and thoroughly cleaned. All dust, debris and metal shavings must be vacuumed up.

2.2 Transport

Transport

Transport the VEX unit on the disposable pallet. Do not lift it with the spigots or connection box.

Transport methods

Transport the VEX unit in one of the following ways:

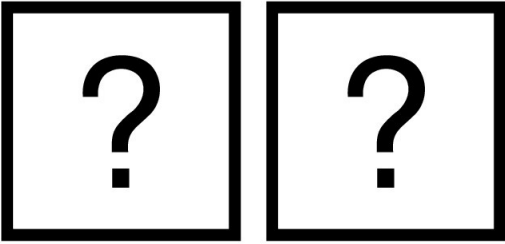
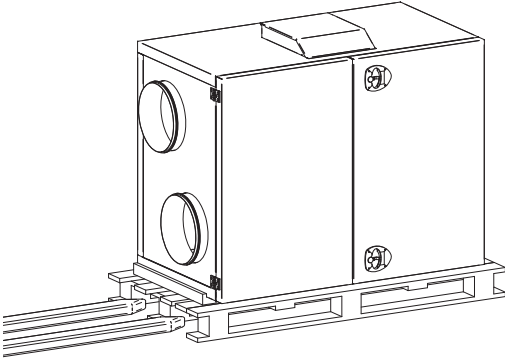
Method	Drawing
<p>Manual transport: Lifting brackets for manual transport can be fitted as shown on the drawing:</p>	
<p>Using pallet truck or fork-lift truck: Lift the VEX unit on the disposable pallet. IMPORTANT: If the disposable pallet cannot be used, the forks on the lifting equipment must be long enough to prevent damage to the bottom of the unit.</p>	

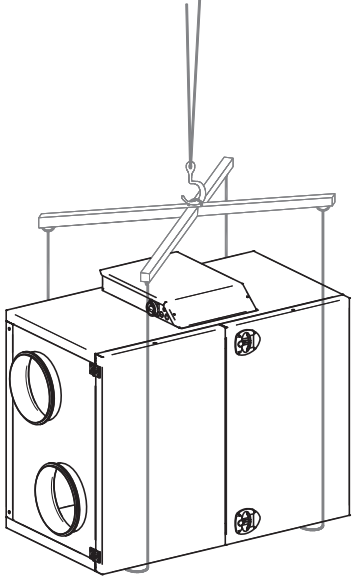
Method	Drawing
<p>Crane:</p> <p> Never lift the VEX unit with the lifting brackets by using a crane.</p> <p>Use straps and lifting yokes to prevent damage to the unit.</p>	 <p style="text-align: right; font-size: small;">RD13391-01</p>

2.2.1 Passage through openings

Height VEX height is 1557 mm + any base spigot (+62 mm).

Width The list below shows how wide the opening has to be for the VEX unit to pass through:

If the opening width is*	Then
less than 785 mm	the unit will not pass through.
785–835 mm	remove doors, see relevant section.
greater than 835 mm	the unit can pass through.

* Measurements are based on the exact dimensions of the air handling unit

2.2.2 Internal transport with reduced weight

Removing the service doors

To remove the service doors:

- Open both doors.
- Using a small punch or similar tool, knock the pin out of the top of the door hinges (A), and lift the doors off.

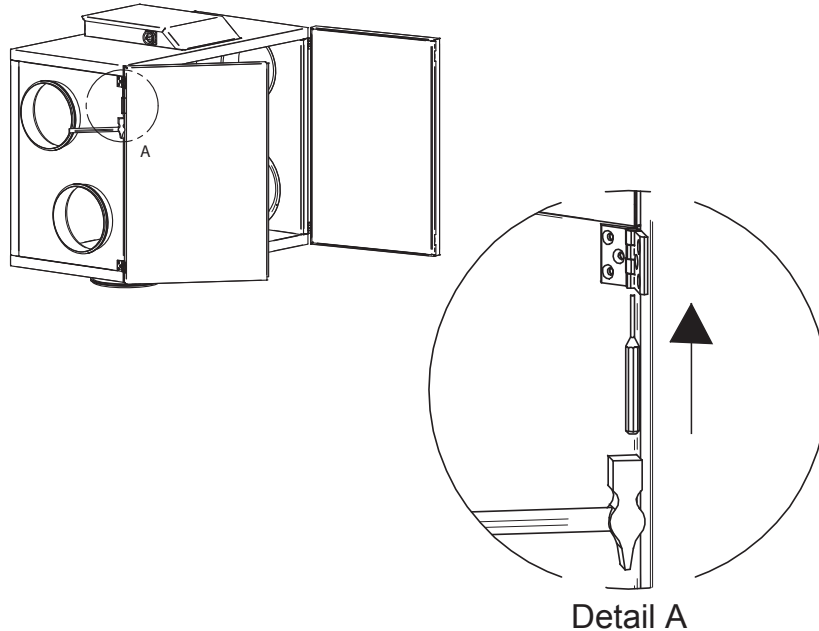

RD10247-02

Weight reduction

The air handling unit's weight can be reduced during transport by removing service doors, fans and counterflow heat exchanger. The table below shows how much weight can be reduced by removing the various parts.

Parts	Weights, VEX150CF
Fan, 2 items at	20 kg = 40 kg
Counter flow heat exchangers, 1 item at	31 kg
Doors, 2 items at	26 kg = 52 kg
Total weight	330 kg

To remove the fan unit

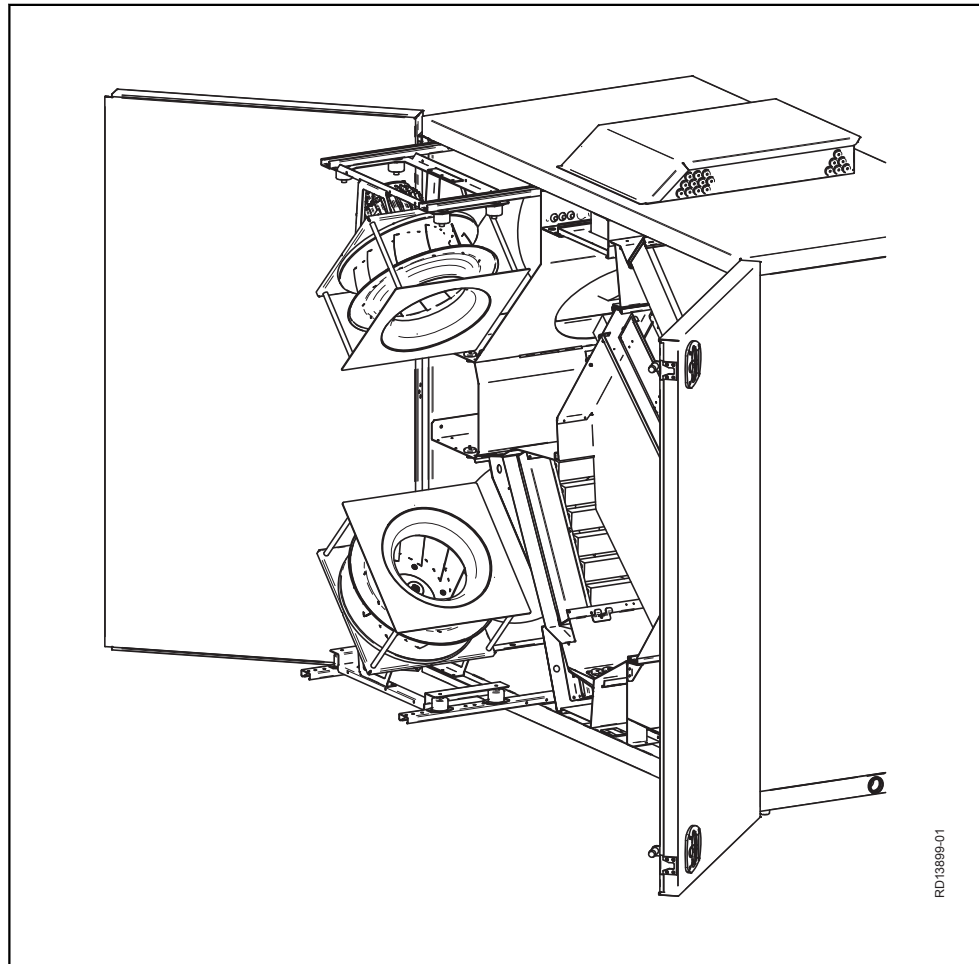

Step	Action
1	Remove the fixing screw from the sliding rail, and release the ties on the motor cable.
2	Pull the fan unit out to the stop (two screws) on the sliding rail.
3	Dismount the motor cable from the motor control on the sliding panel and pull it towards the motor through the rubber grommets.
4	Remove the two sliding rail screws. The fan unit can now be lifted off.

Removal

See section "Maintenance" for instructions for dismounting fans and counterflow heat exchanger and for removal of filters.



3. Mechanical assembly

3.1 Installation

Description It is important that the VEX is installed on a level surface, as this affects the collection and draining of the condensate.

3.1.1 Installation directly on floor

The requirements for the floor surface must be met, see the section entitled "Requirements for underlying surface".

NB After installation, check the VEX unit is completely level.

3.1.2 Installation on mounting base

The EXHAUSTO mounting base enables the VEX unit to be installed correctly. The base is equipped with adjustable levelling screws, so that the air handling unit can be fitted horizontally on a surface that is not level (+/- 20 mm per metre). See the separate instructions for installing the mounting base.

3.2 Condensation outlet



Drain the condensation outlet into a floor gully or similar. The condensation outlet must be fitted with a water trap. See below.

Risk of frost



Where there is a risk of frost: Insulate the condensation outlet and protect it against frost - if necessary, using a heating cable.

3.2.1 Establishment of condensation outlet

Location The following two drawings show examples of how the drain from the condensation outlet can be established and the correct dimensions for the water trap:

Solution with siphon water trap (accessory)

The siphon water trap is easy to install and service.

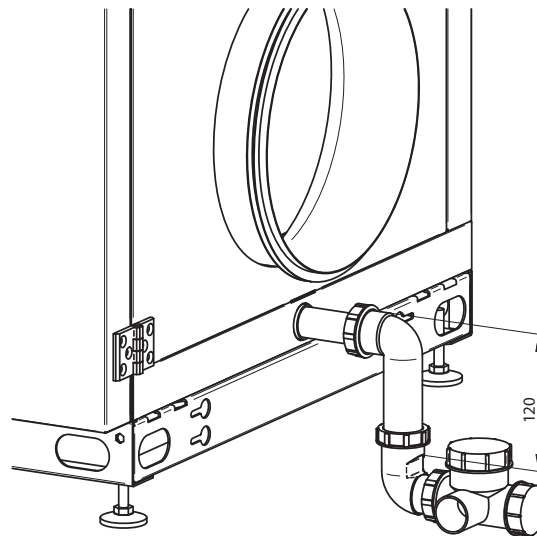

RD13442-01

Solution with HT pipe

Use HT pipe (HT, DN32, DIN4102), if the above solution is not employed (not supplied by EXHAUSTO).

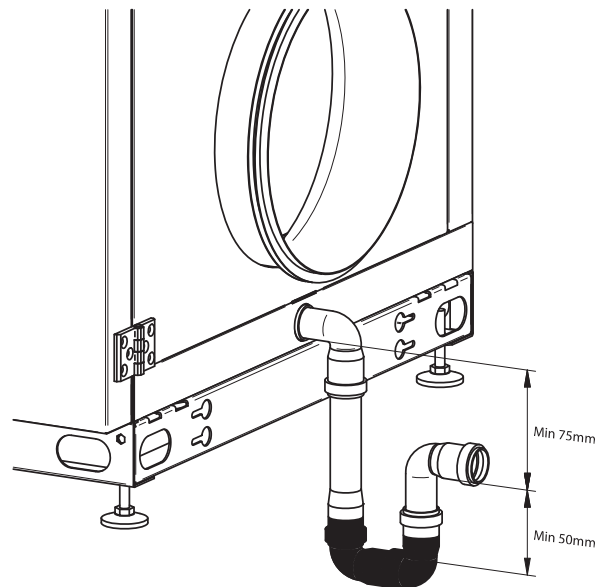

RD101852-02

NB:

If the VEX is erected on a mounting base, this will allow sufficient free height for installing a water trap.



4. Electrical installation

4.1 Electrical installation

See the attached instructions "Guide to Electrical Installation of VEX100 CF with electric heating coil and EXact2 control system":

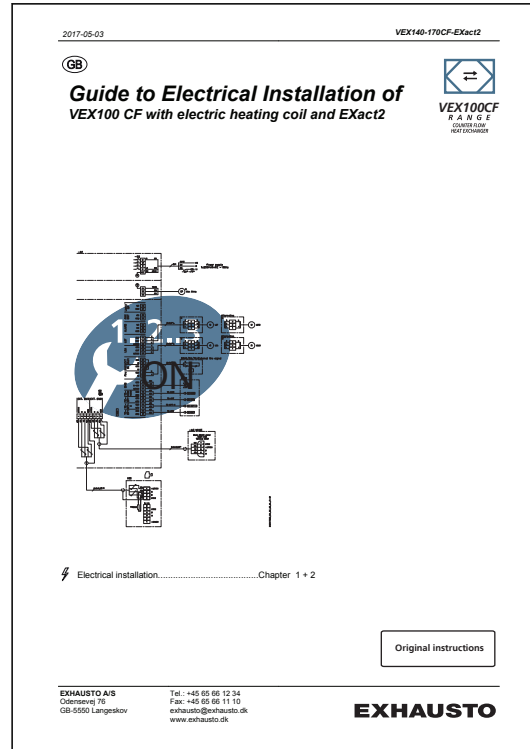



5. Maintenance, hygiene and servicing

5.1 Operating readings via the HMI panel

HMI panel

Refer to the "EXact2 Control System Basic Instructions for VE100/100CF" for instructions on accessing Menu 2 "Operation displays" via the technician menu (access code 1111) to check the unit's operating status.

5.2 Maintenance

5.2.1 Overview of maintenance intervals

The following chart details the recommended maintenance intervals for the VEX. The intervals are a guide and based on normal operation. EXHAUSTO recommends maintenance is adjusted to match the actual operating requirements.

Component	Procedure	Twice a year	Once a year
Filters*	Change filters when HMI displays filter alarm Recommended that both filters are replaced at the same time. NB: The control system can issue a warning when the filter is becoming soiled Filters should be replaced at least:	X	
Filter monitor	Check that all the seals in the filter monitor are tight.		X
Seals and sealing strips	Check that all the seals are tight.		X
Fan	<ul style="list-style-type: none"> Check that the fan impeller is securely fixed to the shaft. Removal of fan unit. See section "Internal transport with reduced weight" Cleaning. See section "Servicing and cleaning" 		X
Counterflow heat exchanger	Clean the heat exchanger. See section "Cleaning of counterflow heat exchanger"		X
Bypass damper	Check damper function		X
Heating coil	Clean the heating coil. See section "Cleaning of heating coil"		X
Safety functions check	<ul style="list-style-type: none"> Fire thermostat check Temperature sensors on heating pipes 		X
Closing damper	Check damper function		X
Condensation outlet	Check that the outlet functions by pouring water in the condensation tray		X

*Filters



Only use original filters

- The provided filter data and pressure loss graphs (section "Technical data") are based on the use of original filters
- EUROVENT certification is only valid if original filters are used
- Use of non-original filters may cause leakage in the VEX and impair filter function
- EXHAUSTO recommends that you register the filter replacement date to ensure filters are replaced at the correct intervals

5.3 Hygiene (VEX100VDI only)

VDI6022 air hygiene standard

To ensure that the VEX100 meets the requirements of the VDI6022 hygiene standard, its design ensures that:

- bacterial growth and dirt accumulation are minimal
- conditions for cleaning are optimum

Filter F7

The outdoor air side of the unit must be fitted with a F7 filter to meet VDI6022 requirements.

5.4 Servicing and cleaning

5.4.1 Filter change



Disconnect power at the isolation switch before opening the door.

Pull the filters out. Remember to check the flow direction - see the arrows on the filter.

Discarded filters must be stored immediately in sealed plastic bags and disposed of responsibly.

Filter change in menu 8.1

After filter change (timer operation only): Go to menu 8.1 in the EXact control system and select "Yes" next to filter change to reset the operating days counter.

5.4.2 Cleaning the fans

Step	Action
1	Switch off the power supply to the unit at the isolation switch before opening the doors.
2	Pull out the fan section: Release the fixing screw on each sliding rail and undo the ties on the motor cables. Pull the fan unit out to the stop (two screws) on the sliding rails.
3	Clean the fan impeller with a vacuum cleaner and wipe down with a damp cloth if necessary. Clean the blades on the fan impeller carefully to avoid disrupting the balance. If there are weights on the fan impeller, these must not be removed.
4	After cleaning the fan impeller, check that the unit does not vibrate when operating.

5.4.3 Cleaning the heating coils

Step	Action
1	Switch off the power supply to the unit at the isolation switch before opening the doors.
2	Vacuum clean the heating coil
3	Check that the fins on the heating coil are not deformed.

The fins are sharp.

5.4.4 Removing and cleaning the counterflow heat exchanger

Warnings



Disconnect power at the isolation switch before opening the doors.



Take care, as the counterflow heat exchanger is heavy - (see weight under Technical Data)





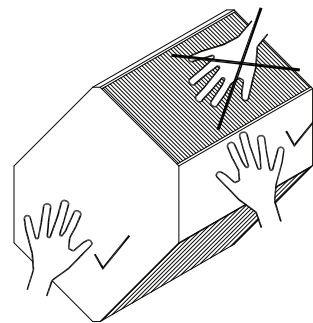

The counterflow heat exchanger fins can be easily damaged - avoid contact with the fins.



5.4.5 Cleaning the counterflow heat exchanger

Step	Action
1	<p>Remove the plug from the bypass motor.</p> <p>Hold down the split pin under the plug using a screw driver as shown on photo</p> <p>Then remove the plug</p>

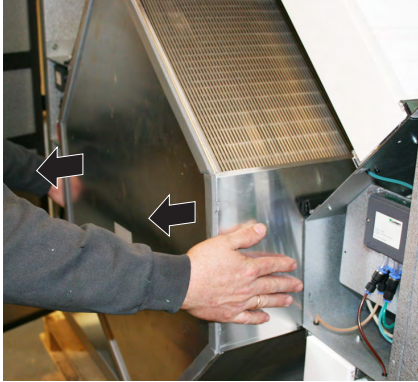

Step	Action	
2	Carefully remove the bypass (do not wrench it out)	
3	Make sure the Tice sensor/fitting is free of the counterflow heat exchanger before extracting it.	
4	Remove the counterflow heat exchanger all the way. Note the weight of the heat exchanger, see technical data – min. two people when lifting.	
5	Clean the counterflow heat exchanger by flushing with hot water or by pressure hosing. Max. water temperature 90°C.	
6	Replace the counterflow heat exchanger and then the bypass. Check that the Tice sensor is correctly positioned between the heat exchanger fins, as the sensor will not measure correctly otherwise.	
7	Re-insert the plug for the bypass motor.	



6. Technical data

6.1 Weight, corrosion class, temperature ranges, etc.

Weight

VEX total weight	330 kg
Doors	2 x 26 kg
Counterflow heat exchanger	31 kg
Fan unit	2 x 20 kg
VEX for internal transport (without doors, heat exchanger and fan unit)	247 kg

Corrosion class

Corrosion class	Corrosion class C4 in accordance with EN ISO 12944-2
-----------------	--

Temperature ranges

Outdoor air temperature	-40°C to +35°C
Ambient temperature	-30°C to +50°C

At temperatures below -25°C (with outdoor installation), use of a thermostatically controlled heater in the automated control box is recommended.

HMI-panel

Ingress protection	IP20
Ambient temperature	0°C - +50°C

At temperatures below 0°C the display may react more slowly than usual.

Fire thermostats

Cut-out temperature, BT70	70°C
Cut-out temperature, BT50	50°C
Cut-out temperature, BT40	40°C
Max. ambient temperature, sensor	250°C
Ambient temperature, thermostat housing	0°C - +80°C
Sensor length	125 mm
Ingress protection	IP40

Temperature drop before reconnection possible min. 15°K

Motor damper

Motor damper type	LS (closing damper)	LSR (closing damper, spring return)
Type	LS400-24	LSR400-24
Designation	LSA/LSF	LSFR
Motor type	NM24-F	AF-24
Rotation time	75–150 s	open: 150 s close: 16 s
Ingress protection	IP42	IP42
Ambient temperature	-20°C to +50°C	-30°C to +50°C
Damper depth	100 mm	100 mm

A maximum of two LSFR dampers or four LSA/LSF dampers may be connected.

6.2 Compact filters

Filter data, VEX150

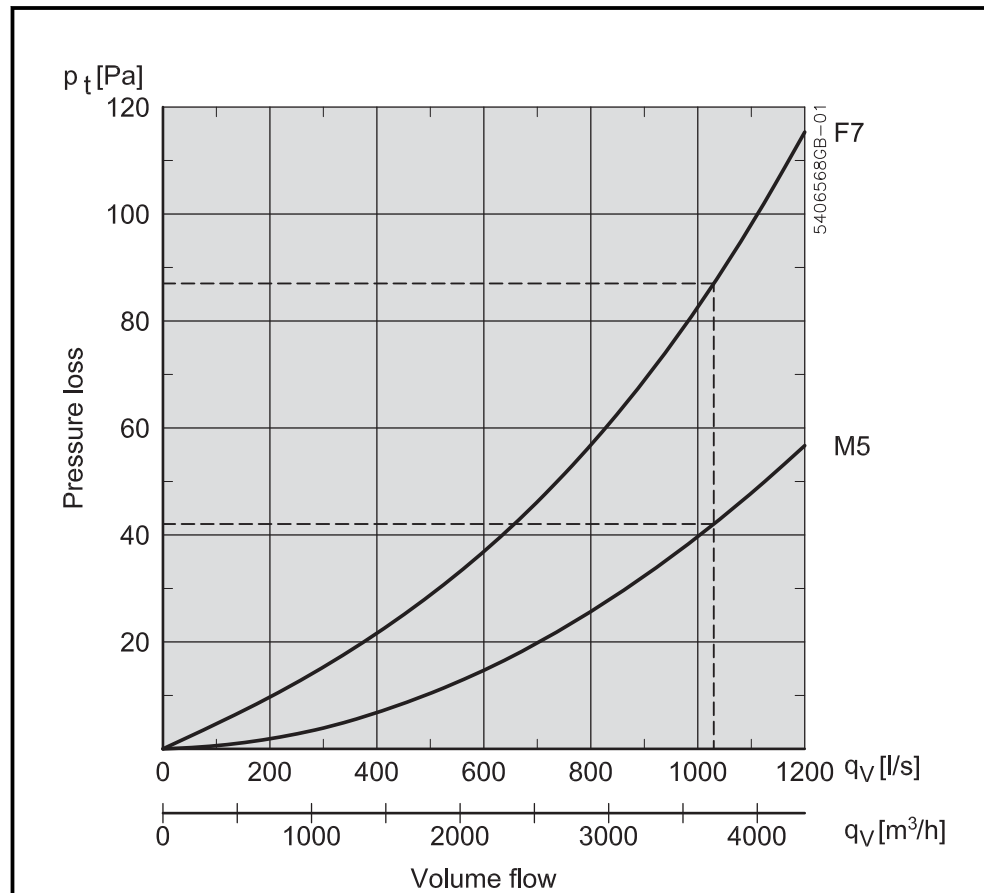

Data	Device	VEX150	
		M5	F7
Dimensions: h x w, 1 item per air direction	mm	577 x 732	577 x 732
Thickness of compact filter	mm	96	96
Filter area	m ²	5.0	15.7
Filter class		M5	F7
Retention efficiency in accordance with EN779: 2012	%	97	99
Efficiency (particle size 0.4µm)	%	45	82
Volume flow rate	l/s	1030	1030
Initial pressure drop	Pa	42	87
Recommended final pressure drop at normal volume flow rate	Pa	142	187
Temperature resistant to	°C	70	70



EUROVENT certification is only valid if original filters are used. For more details about original filters, see section "Maintenance".

6.3 Electric heating coil

Electric heating coil

HCE	
Voltage per electric heating element	1 x 230V
Output	2.0 kW
Supply voltage for connection box:	
Star connection	3 x 400V + N
Thermal fuse, TSA70	70 °C
Thermal fuse, TSA90	90 °C
Temperature tolerance	±5 K
Temperature drop before reconnection possible	15 K

Diagram - temperature rise

The diagram below can be used to determine the air temperature increase at a given airflow and electric heating coil size.

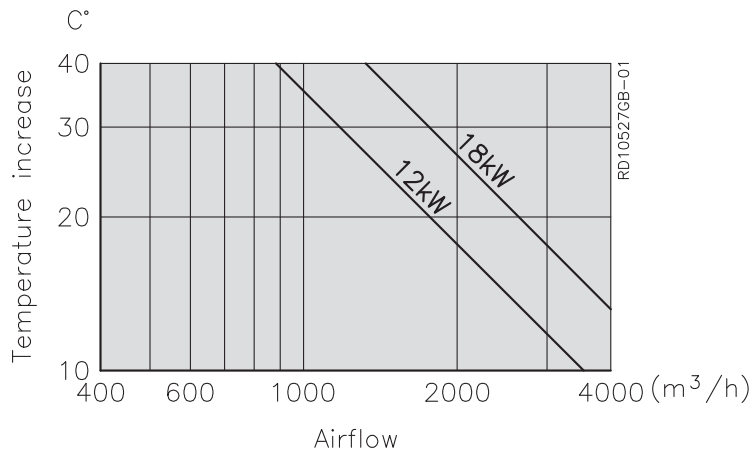

Examples: Pressure drop across electric heating coil

- At airflow of 2900m³/h:
- HCE 12 kW : 5 Pa
 - HCE 18 kW: 10 Pa

6.4 Capacity diagram

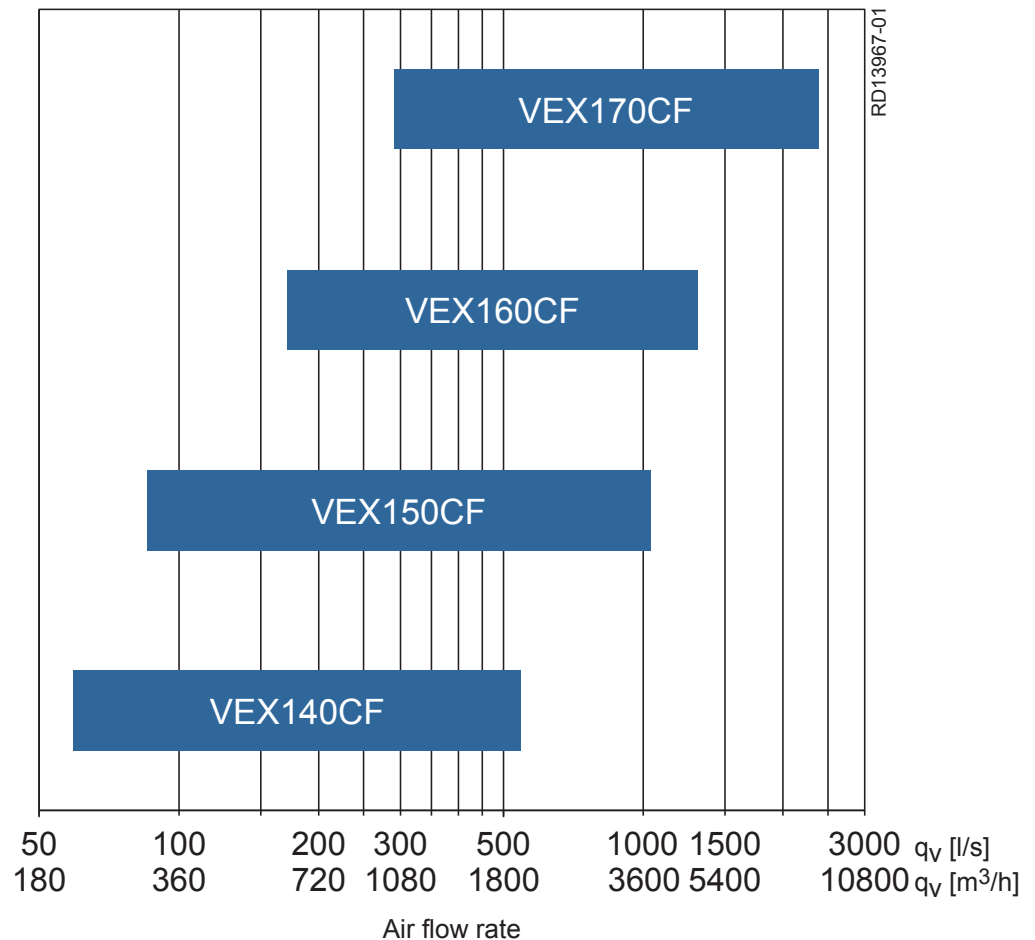

Recommendation



You are recommended to make a more precise calculation of the unit's capacity with the EXselect calculation program, available on the EXHAUSTO web-site.

6.5 Ordering spare parts

Find production number

When ordering spares, please state the relevant production part number. This will ensure that the correct parts are delivered. The production number is given on the front of the VEX guidelines and on the VEX rating plate.

Contact:

Contact your local EXHAUSTO office service department to order a spare part. Contact information is given on the back cover of these instructions. See also the "Layout" section for an overview of the position and designation of parts in the VEX.

6.6 Environmental declaration

Environmental documentation

The unit can be disassembled into individual product parts when outworn and in need of disposal.

Product parts	Material	Handling
Sheet parts	Aluzinc	For recycling after disassembly
Condensation tray	Stainless steel	For recycling after disassembly
Bypass dampers, heat exchangers and metal sections	Aluminium	For recycling
Insulation	Mineral wool	For recycling after disassembly
Door gasket	CFC and HCFC-free cellular rubber	Dumping or incineration
Fan motors, bypass motors	Aluminium, steel, copper and plastic	For recycling after disassembly
Control unit	Electronic components	For recycling by an authorised enterprise
Cassette filter	Fibreglass and plastic	Dumping or incineration
Unit is supplied on disposable pallets	Wood	Dumping or incineration

Percentage weight

Handling	Percentage weight of materials per unit
For recycling	11% (mineral wool)
For recycling	85% (63% Aluzinc, 16% aluminium, 3.5% steel/iron, 2% stainless steel and 1% copper)
Dumping or incineration	2% (Wood, filter paper, cellular rubber)
Other	1.5% (electronic components)
Total	100%



Scan code and go to addresses at
www.exhausto.com