

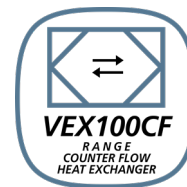



GB



VEX150CF for third party control system with water heating coil HCW



	Product information.....	Chapter 1 + 6
	Mechanical assembly.....	Chapter 2 + 3
	Electrical installation.....	Chapter 4
	Maintenance.....	Chapter 5

Original instructions



1. Product information

1.1. Designations used in these instructions	6
1.1.1. Designations used in these instructions.....	6
1.2. Application	6
1.3. Location requirements	6
1.3.1. Space requirements.....	7
1.3.2. Requirements for underlying surface.....	7
1.3.3. Condensation outlet.....	8
1.3.4. Requirements for duct system.....	8
1.4. Description	9
1.4.1. Horizontal VEX - design.....	9
1.4.2. Vertical VEX - design.....	11
1.4.3. Parts of the VEX unit.....	12
1.5. Principal dimensions, Horizontal VEX	12
1.6. Principal dimensions, Vertical VEX	14



2. Handling

2.1. Unpacking	17
2.2. Transport	17
2.2.1. Transport of Horizontal air handling units.....	17
2.2.2. Transport of Vertical air handling units.....	18
2.2.3. Passage through openings.....	19
2.2.4. Internal transport with reduced weight.....	20



3. Mechanical assembly

3.1. Installation of Horizontal and Vertical VEX	24
3.1.1. Installation directly on floor.....	24
3.1.2. Installation on mounting base.....	24
3.2. Condensation outlet	24
3.2.1. Establishment of condensation outlet.....	24
3.3. Water heating coil	26
3.3.1. Principles for connecting the water heating coil.....	26
3.3.2. Bleeding of coils.....	27
3.3.3. MVM valve.....	28



4. Electrical installation

4.1. Electrical installation	29
---	-----------



5. Maintenance, hygiene and servicing

5.1. Maintenance	30
5.1.1. Overview of maintenance intervals.....	30
5.2. Hygiene (VEX100VDI only)	30
5.3. Servicing and cleaning	31
5.3.1. Filter replacement.....	31
5.3.2. Cleaning the fans.....	31
5.3.3. Cleaning the heating coils.....	31
5.3.4. Removing and cleaning the counterflow heat exchangers.....	31
5.3.5. Cleaning the counterflow heat exchanger.....	32
5.4. Airflow measurement	33
5.4.1. Determining airflow and pressure.....	33



6. Technical data

6.1. Weight, corrosion class, temperature ranges, etc	36
6.2. Panel filters	37
6.3. Water heating system	38
6.4. Capacity diagram	38
6.5. EC Declaration of Conformity	38
6.6. Ordering spare parts	38

6.7. Environmental declaration.....39

Symbols, terms and warnings

Prohibition symbol



Failure to observe instructions marked with a prohibition symbol may result in serious or fatal injury.

Danger symbol



Failure to observe instructions marked with a danger symbol may result in personal injury and/or damage to the unit.

Scope

This instruction manual is for use with EXHAUSTO VEX-type air handling units. Please refer to the product instructions regarding accessories and extra equipment.

The instructions must be fully observed to ensure personal safety and to protect the equipment and ensure its correct operation. EXHAUSTO A/S accepts no liability for accidents caused by equipment not used in accordance with the manual's instructions and recommendations.

Supply air/extract air

This instruction manual uses the following terminology:

- Supply air
- Extract air
- Outdoor air
- Exhaust air

Accessories

The confirmation of order states which accessories are delivered with the VEX unit.

Lock the air handling unit during operation

The VEX unit must always be locked during operation:

- Use the cylinder lock in the handle. **Remember** to remove the key from the lock.
- Or use a padlock. Use the handle's built-in padlock fixture

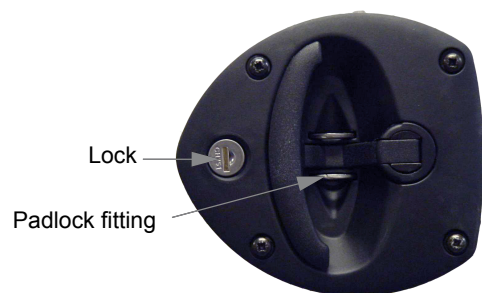

Warnings:

Opening the air handling unit



Do not open the service doors until the supply voltage has been disconnected at the isolation switch and the fans have stopped.

Prohibited uses



The VEX unit is not to be used to transport solid particles or in areas where there is a risk of explosive gases.

No duct connection



If one or more of the spigots is not connected to a duct: Fit a protective net to the spigots with a maximum mesh width of 20 mm (in accordance with EN294).

Information plate

The VEX unit rating plate shows:

- VEX unit, type (1)
- production number (2)

EXHAUSTO		CE	
<small>Company: S.p.A. - Via S. Pietro - 20090 Lodi - Italy Contact: +39 0368 71110 - Fax: +39 0368 71244</small>			
Type	V150CFHLECW2	← Icu = 10kA	1
	No./Year 2406294/2017	←	2
Supply	Voltage: 3x400V+N+PE ~50Hz	Current: 15A	
Heat	HCW		
FAN ECO design	$\eta = 60,0\%$ (A) N62 (2015) N = 74.4 VSD integrated		

NB:

Always have the production number ready when contacting EXHAUSTO A/S.



1. Product information

1.1 Designations used in these instructions

1.1.1 Designations used in these instructions

The simplified diagram shows a VEX unit with LEFT fan placement.

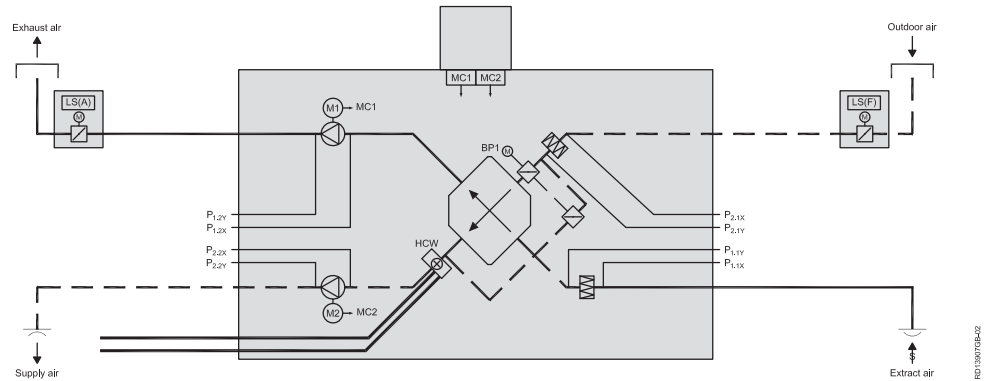

Component	Function
BP1	Bypass motor
HCW	Water heating coil
LS (F)	Closing damper, outdoor air
LS (A)	Closing damper, exhaust air
MC1	Motor controller 1 for extract air motor
MC2	Motor controller 2 for supply air motor
M1	Extract air motor
M2	Supply air motor
P _{1.2X} and P _{1.2Y}	Points for measuring pressure rise across extract air fan
P _{2.2X} and P _{2.2Y}	Points for measuring pressure rise across supply air fan
P _{2.1X} and P _{2.1Y}	Points for measuring pressure loss across outdoor air filter
P _{1.1X} and P _{1.1Y}	Points for measuring pressure loss across extract air filter

1.2 Application

Comfort ventilation EXHAUSTO VEX is used for comfort ventilation tasks.
Operating temperature range for the unit – see section "Technical data".

Prohibited uses The VEX unit is not to be used to transport solid particles or in areas where there is a risk of explosive gases.

1.3 Location requirements

Location The air handling unit is designed for indoor fitting.

Outdoor

VEX100H: The VEX100 horizontal model can be ordered for outdoor installation, in which case it is provided with a cover (accessory VEX100OD).

1.3.1 Space requirements

The drawings below show how much space is needed for opening the doors and servicing the air handling unit, e.g. changing filters, cleaning, servicing, etc.

NB:

For servicing, the VEX must have a free height of at least 300 mm above the connection box. (**For Vertical:** For servicing, the VEX must have a free height of at least 300 mm in front of the connection box.)

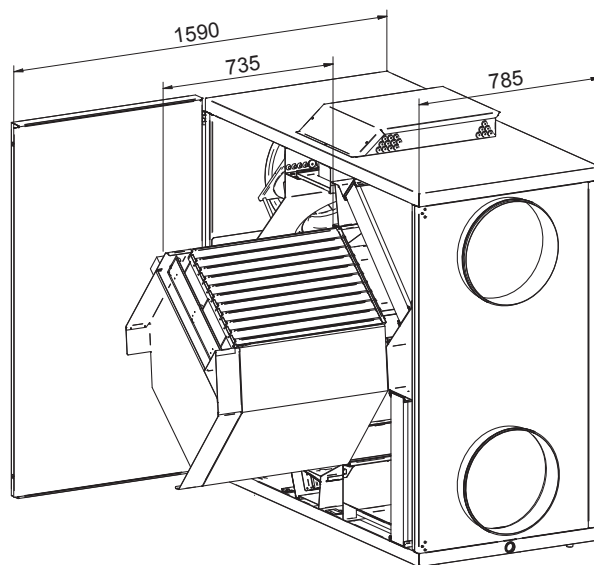
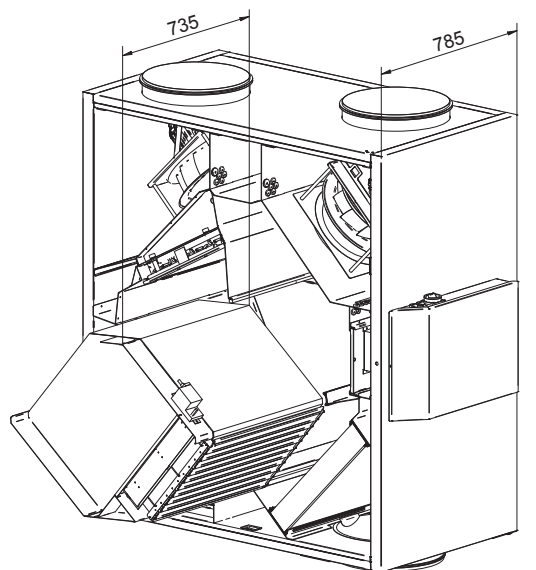
Horizontal VEX**Vertical VEX****1.3.2 Requirements for underlying surface****Horizontal and Vertical VEX**

When floor-mounting the unit, the surface must be:

- flat
- level (+/- 3 mm per metre)
- hard
- resistant to vibration

1.3.3 Condensation outlet

A condensation outlet must be installed in the immediate vicinity of the unit. See also "Mechanical assembly" section.

1.3.4 Requirements for duct system

Connection to duct system

To achieve maximum performance and minimal energy consumption, the unit should be connected to a straight duct at least 750 mm long, before and after the unit.

Silencers

The duct system must be fitted with silencers specified by the Project Manager, which meet the requirements of the operating area.

Insulation



The duct system must be insulated against:

- condensation
- sound
- thermal loss

Condensation

Condensation in the ducts may occur when the exhaust/outdoor air has high humidity. EXHAUSTO recommends a condensation outlet is also fitted at the lowest point in the ducts.

Outdoor air intake

The outdoor air intake must be dimensioned with sufficiently low airflow to prevent rain and snow being drawn into the duct system.

No duct connection



If one or more of the spigots is not connected to a duct: Fit a protective net to the spigots with a maximum mesh width of 20 mm.

1.4 Description

1.4.1 Horizontal VEX - design

VEX unit construction

The following drawings show an overview of the design of left and right models of VEX units (shown without door).

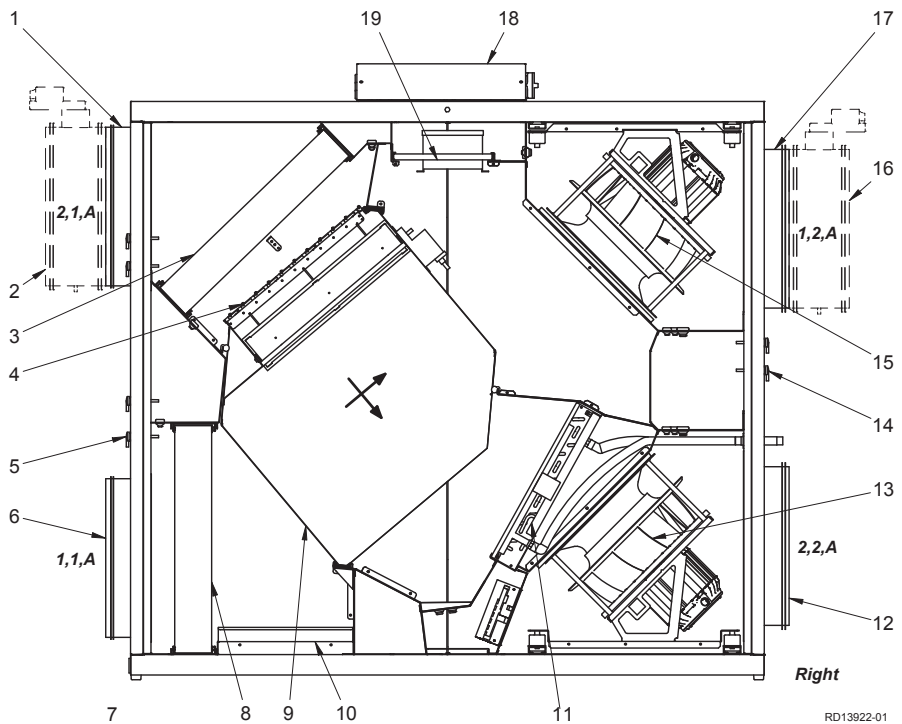
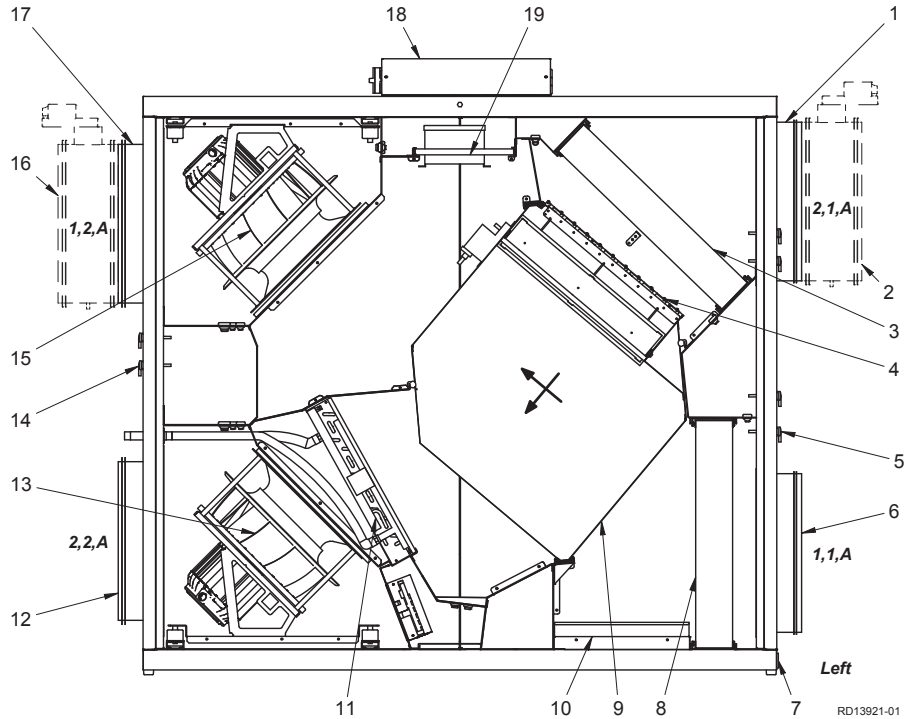

Pos.	Function	
1	Spigot 2.1.A	Outdoor air spigot The spigot can also be positioned on the top of the air handling unit (2.1.B).
2	Closing damper LS	Closing damper, outdoor air, LSF (accessory)
3	Outdoor air filter	Filters outdoor air
4	Bypass damper	For operation with heat recovery, the bypass damper is closed so that the air passes through the counterflow heat exchanger. For bypass operation, the damper is open, and the air bypasses the heat exchanger
5	Measurement socket	Measurement socket for pressure loss across the filters
6	Spigot 1,1,A	Extract air spigot
7	Condensation outlet	Channels condensate to the drain
8	Extract air filter	Filters extract air
9	Counterflow heat exchanger	Conducts heat from extract air to supply air
10	Condensation tray	Collects the condensate and drains it away from the cross-flow heat exchanger to the condensation outlet
11	Water heating coil with bleed screw	Heats supply air if heat recovery is insufficient.
12	Spigot, 2,2,A	Supply air spigot. The spigot can also be positioned at the bottom of the air handling unit (2.2.B)
13	Supply air fan	For outdoor air/supply air
14	Measurement socket	Measurement socket for airflow calculation.
15	Extract air fan	For exhaust air/extract air
16	Closing damper LS	Closing damper – exhaust air, LSA (accessory)
17	Spigot 1,2,A	Extract air spigot The spigot can also be positioned on the top of the unit (1.2.B).
18	Connection box	Positioning of terminal board for electrical connection
19	Extraction plate	Positioning of motor controls

1.4.2 Vertical VEX - design

VEX unit construction

The following drawings show an overview of the design of left and right models of VEX units (shown without door).

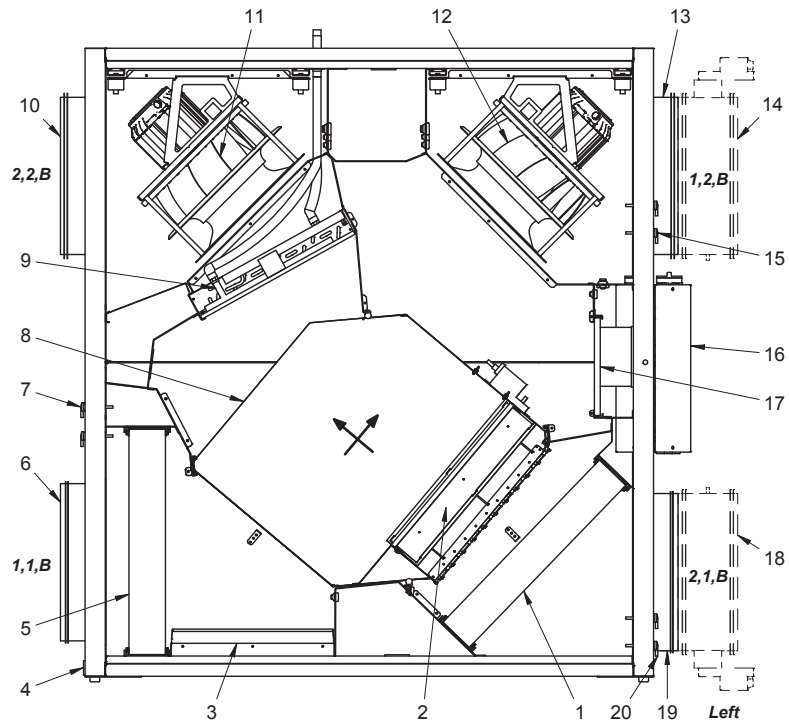

RD13923-01

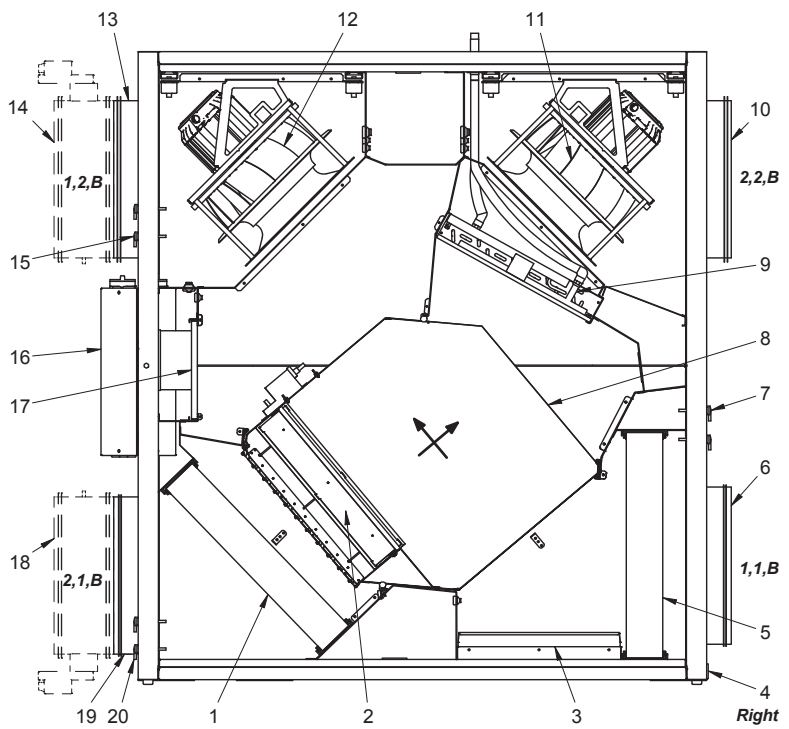

RD13924-01

Pos.	Part	Function
1	Outdoor air filter	Filters outdoor air
2	Bypass damper	For operation with heat recovery, the bypass damper is closed so that the air passes through the counterflow heat exchanger. For bypass operation, the damper is open, and the air bypasses the heat exchanger
3	Condensation tray	Collects the condensate and drains it away from the cross-flow heat exchanger to the condensation outlet
4	Condensation outlet	Channels condensate to the drain
5	Extract air filter	Filters extract air
6	Spigot 1,1,B	Extract air spigot
7	Measurement socket	Measurement socket for pressure loss across extract air filter
8	Counterflow heat exchanger	Conducts heat from extract air to supply air
9	Water heating coil with bleed screw	Heats supply air if heat recovery is insufficient.
10	Spigot 2,2,B	Supply air spigot. The spigot can also be positioned on the top of the air handling unit (2.2.A).
11	Supply air fan	For outdoor air/supply air.
12	Extract air fan	For exhaust air/extract air
13	Spigot 1,2,B	Extract air spigot The spigot can also be positioned on the top of the unit (1,2,A).
14	Closing damper LS	Closing damper – exhaust air, LSA (accessory)
15	Measurement socket	Measurement socket for airflow calculation.
16	Connection box	Positioning of terminal board for electrical connection
17	Extraction plate	Positioning of motor controls
18	Closing damper LS	Closing damper, outdoor air, LSF (accessory)
19	Spigot 2,1,B	Outdoor air spigot The spigot can also be positioned at the bottom of the air handling unit (2.1.A)
20	Measurement socket	Measurement socket for pressure loss across outdoor air filter

1.4.3 Parts of the VEX unit

Cabinet

The inside and outside of the cabinet are made of Aluzinc® The cabinet has been insulated with 50 mm mineral wool.

Fans

The unit contains two centrifugal fans with backward curved blades for extract air and supply air.

Counterflow heat exchanger

The counterflow heat exchanger in the unit is mounted with a modulating bypass damper. The counterflow heat exchanger can be removed and cleaned.

Filters

The unit includes integral panel filters for both extract air and supply air.

1.5 Principal dimensions, Horizontal VEX

VEX150H, Left

The following drawing gives the principal dimensions:

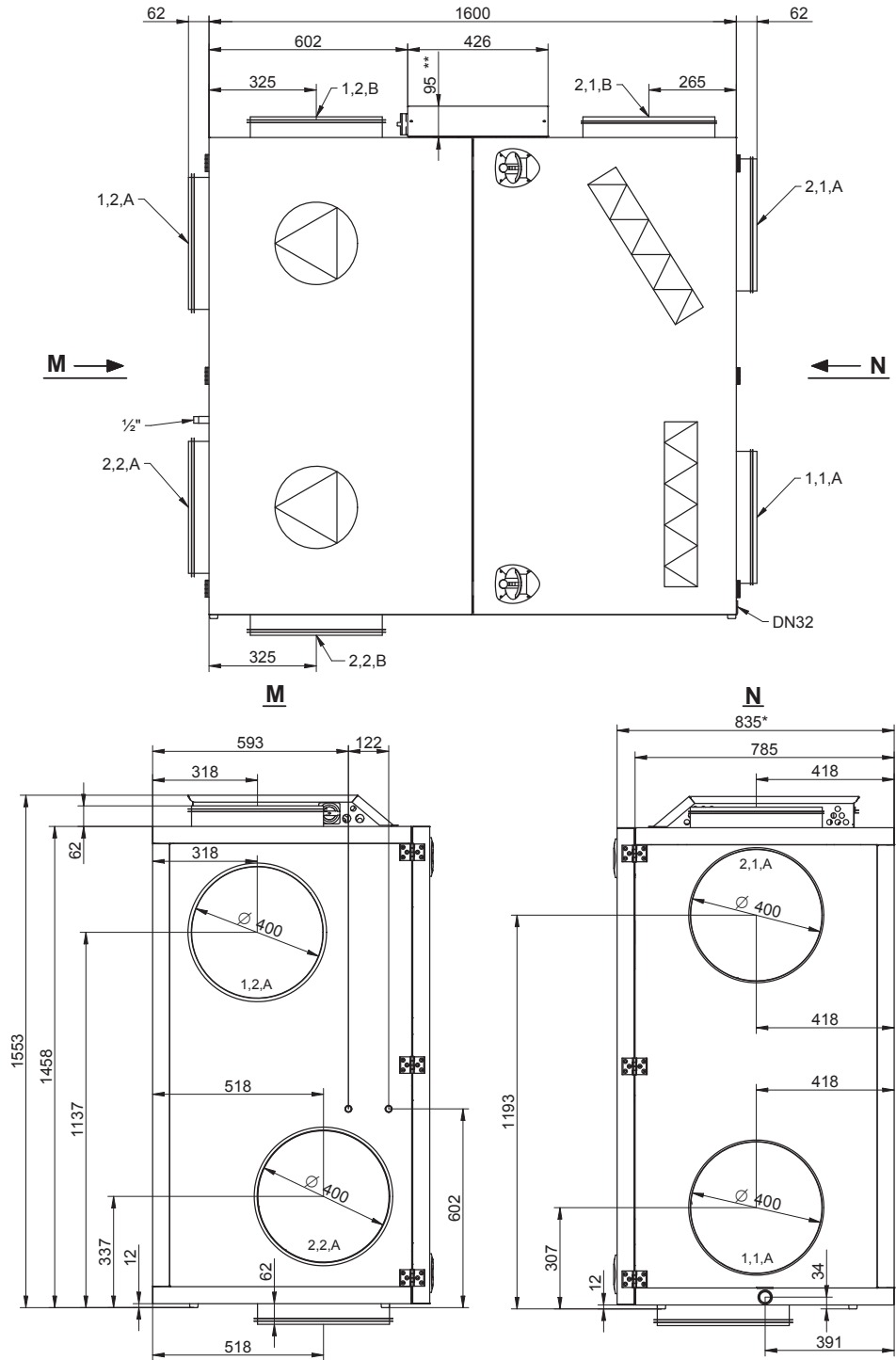

NB:

- The drawing shows all of the spigot positioning options.
- * Allow a distance for service in front of the unit equivalent to the unit depth.
- ** Allow a min. of 300 mm free height for service.

VEX150H, Right

The following drawing gives the principal dimensions:

RD13878-01

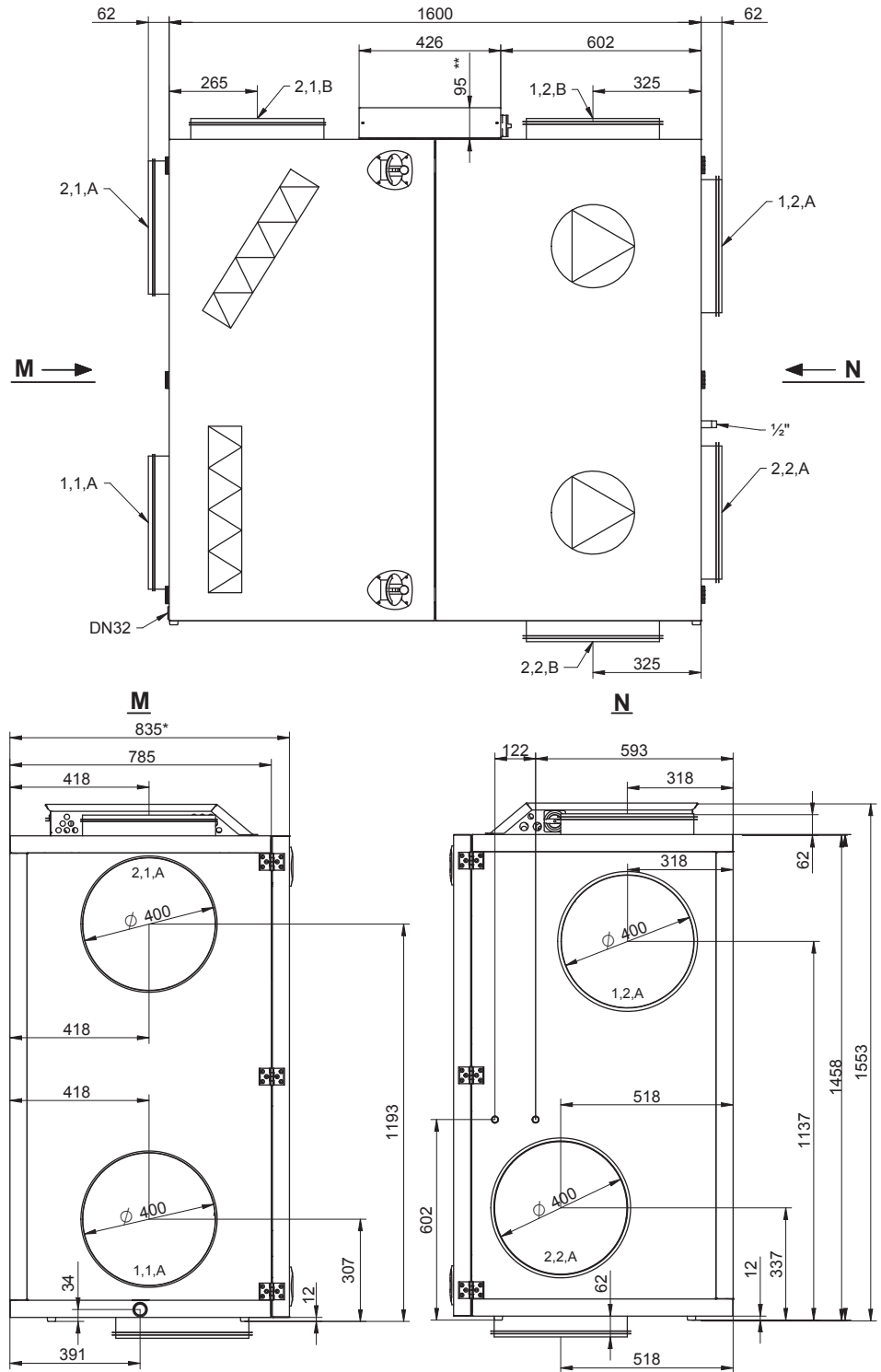

RD13879-01

NB: The drawing shows all of the spigot positioning options.
 * Allow a distance for service in front of the unit equivalent to the unit depth.
 ** Allow a min. of 300 mm free height for service.

1.6 Principal dimensions, Vertical VEX

VEX150V, Left The following drawing gives the principal dimensions:

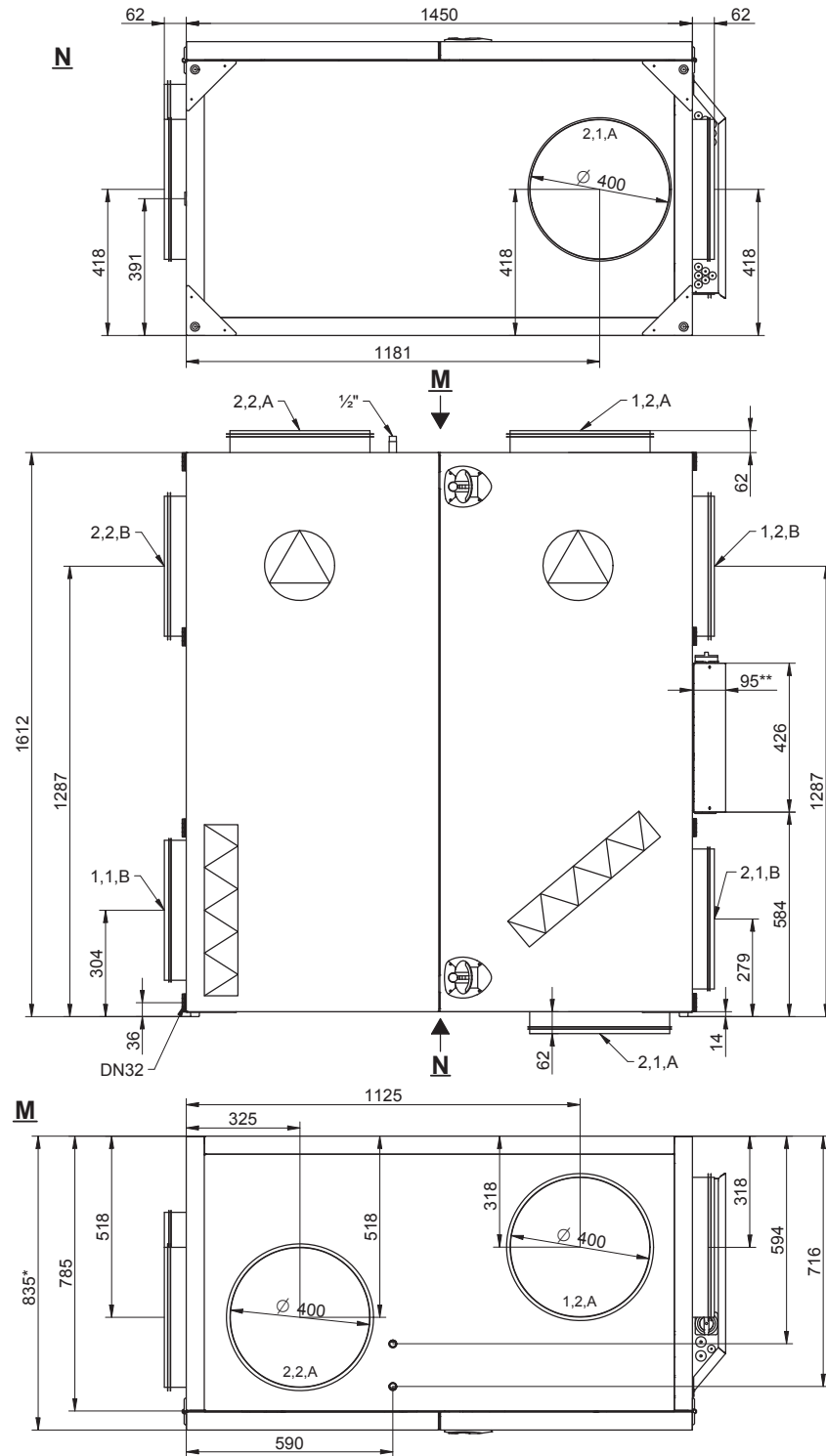

RD13880-01

NB:

- The drawing shows all of the spigot positioning options.
- * Allow a distance for service in front of the unit equivalent to the unit depth.
- ** Allow a min. of 300 mm free height for service.

VEX150V, Right

The following drawing gives the principal dimensions:

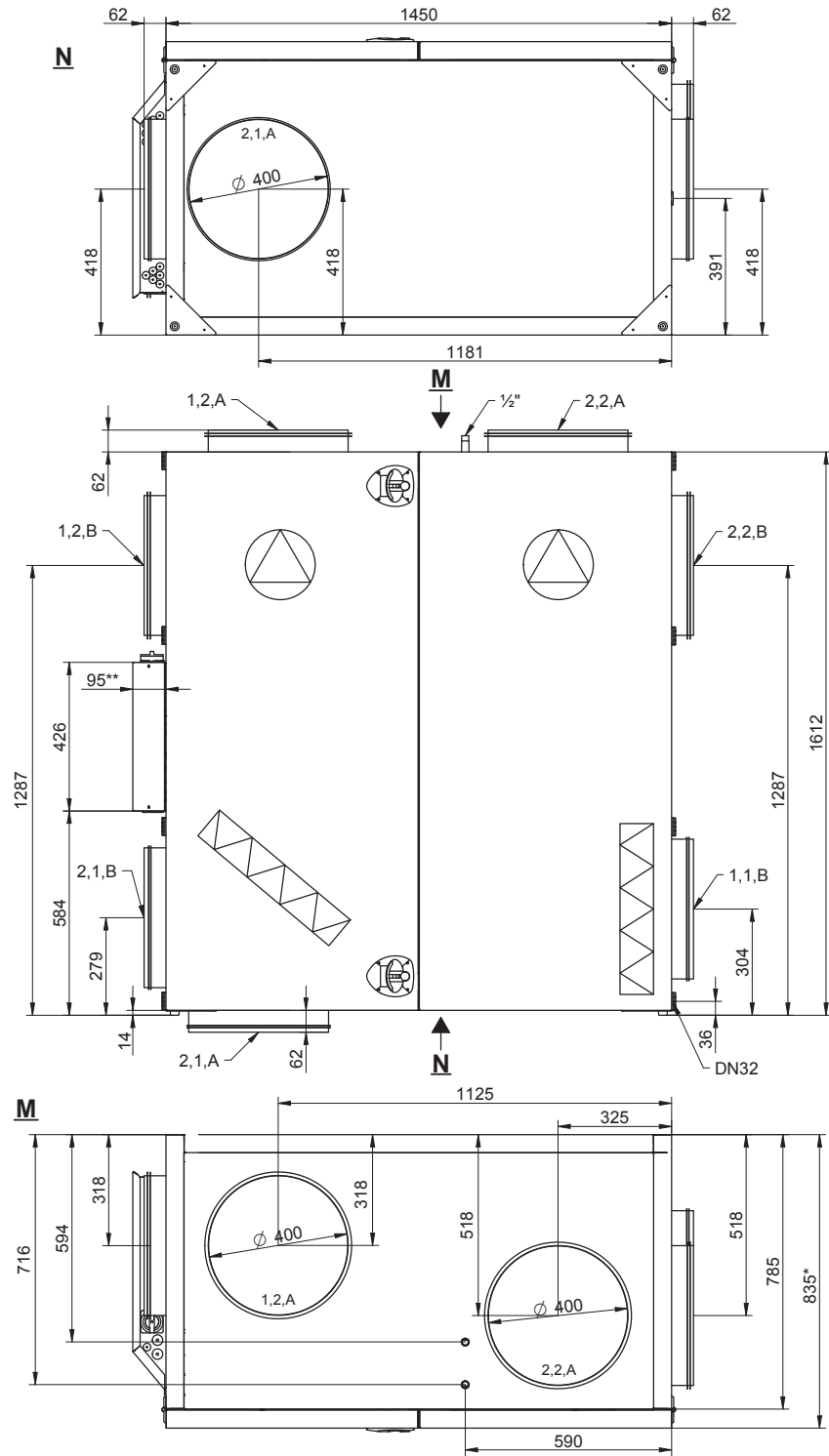

RD13881-01

NB:

- The drawing shows all of the spigot positioning options.
- * Allow a distance for service in front of the unit equivalent to the unit depth.
- ** Allow a min. of 300 mm free height for service.



2. Handling

2.1 Unpacking

Delivery

The following components are supplied:

- VEX unit
- Accessories supplied

Packaging

The unit is delivered on a disposable pallet and packed in clear plastic.

NB

Once the plastic has been removed, the unit must be protected against dirt and dust:

- **The covers on the spigots must not be removed until the spigots are connected to the ventilation ducts.**
- **Whenever possible, keep the unit closed during fitting.**

The unit should be cleaned before it is used.

Once the VEX unit is fitted, it must be checked and thoroughly cleaned. All dust, debris and metal shavings must be vacuumed up.

2.2 Transport

Transport



Transport the VEX unit on the disposable pallet. Do not lift it with the spigots or connection box.

2.2.1 Transport of Horizontal air handling units

Transport methods

Transport the VEX unit in one of the following ways:

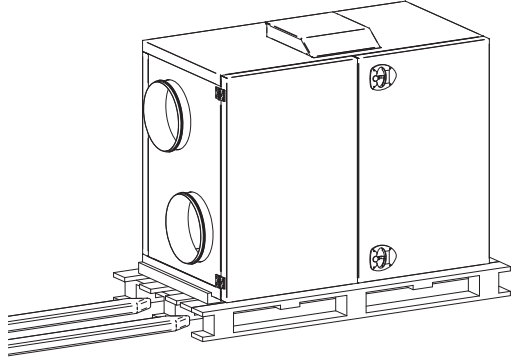

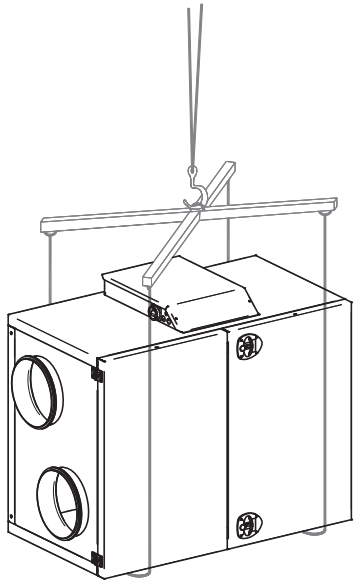
Method	Drawing
Manual transport: Lifting brackets for manual transport can be fitted as shown on the drawing:	

Method	Drawing
<p>Pallet truck or fork-lift truck: Lift the VEX unit on the disposable pallet. IMPORTANT: If the disposable pallet cannot be used, the forks on the lifting equipment must be long enough to prevent damage to the bottom of the unit.</p>	
<p>Crane:  Never lift the VEX unit with the lifting brackets by using a crane. Use straps and lifting yokes to prevent damage to the unit.</p>	

2.2.2 Transport of Vertical air handling units

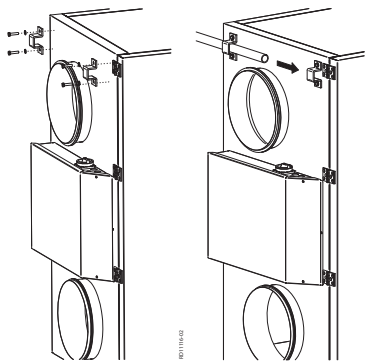
Transport methods Transport the VEX unit in one of the following ways:

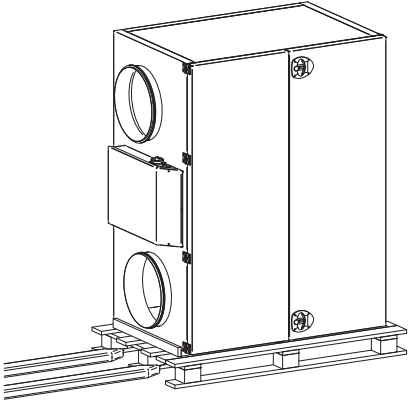
Method	Drawing
<p>Manual transport: Lifting brackets for manual transport can be fitted as shown on the drawing:</p>	

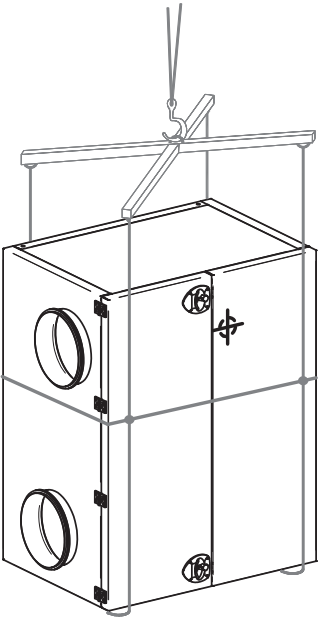
Method	Drawing
<p>Using pallet truck or fork-lift truck: Lift the VEX unit on the disposable pallet. IMPORTANT: If the disposable pallet cannot be used, the forks on the lifting equipment must be long enough to prevent damage to the bottom of the unit.</p>	
<p>Crane:</p> <p> Never lift the VEX unit with the lifting brackets by using a crane.</p> <p>Use straps and lifting yokes to prevent damage to the unit.</p>	

Weight

For information about the weight of the unit, see the section "Technical specifications".

2.2.3 Passage through openings

Height

Horizontal VEX: 1557 mm + any spigot in bottom (+62 mm).

Vertical VEX: 1612 mm + any spigot in top (+62 mm) and bottom (+62 mm).

Width

The list below shows how wide the opening has to be for the VEX unit to pass through:

If the opening width is*	Then
less than 785 mm	the unit will not pass through.
785–835 mm	remove doors, see relevant section.
greater than 835 mm	the unit can pass through.

* Measurements are based on the exact dimensions of the air handling unit

2.2.4 Internal transport with reduced weight

Weight reduction

The air handling unit's weight can be reduced during transport by removing service doors, fans and counterflow heat exchanger. The table below shows how much weight can be reduced by removing the various parts.

Parts	Weights, VEX150CF
Fan, 2 items at	20 kg = 40 kg
Counter flow heat exchangers, 1 item at	31 kg
Doors, 2 items at	26 kg = 52 kg
Total weight	330 kg

Horizontal and Vertical VEX: Removing the service doors

To remove the service doors:

- Open both doors.
- Using a small punch or similar tool, knock the pin out of the top of the door hinges (A), and lift the doors off.

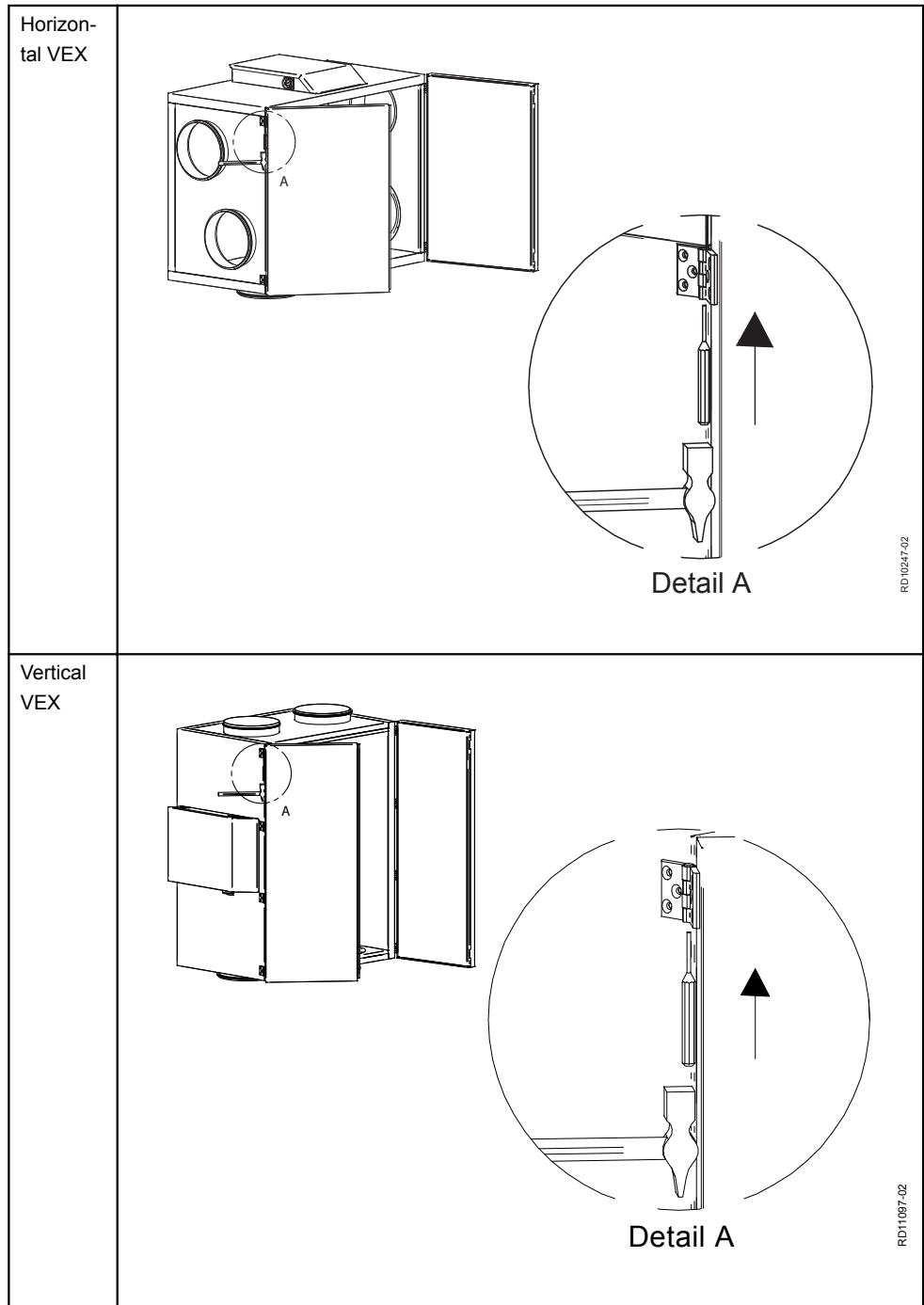

Horizontal VEX

To remove the fan unit

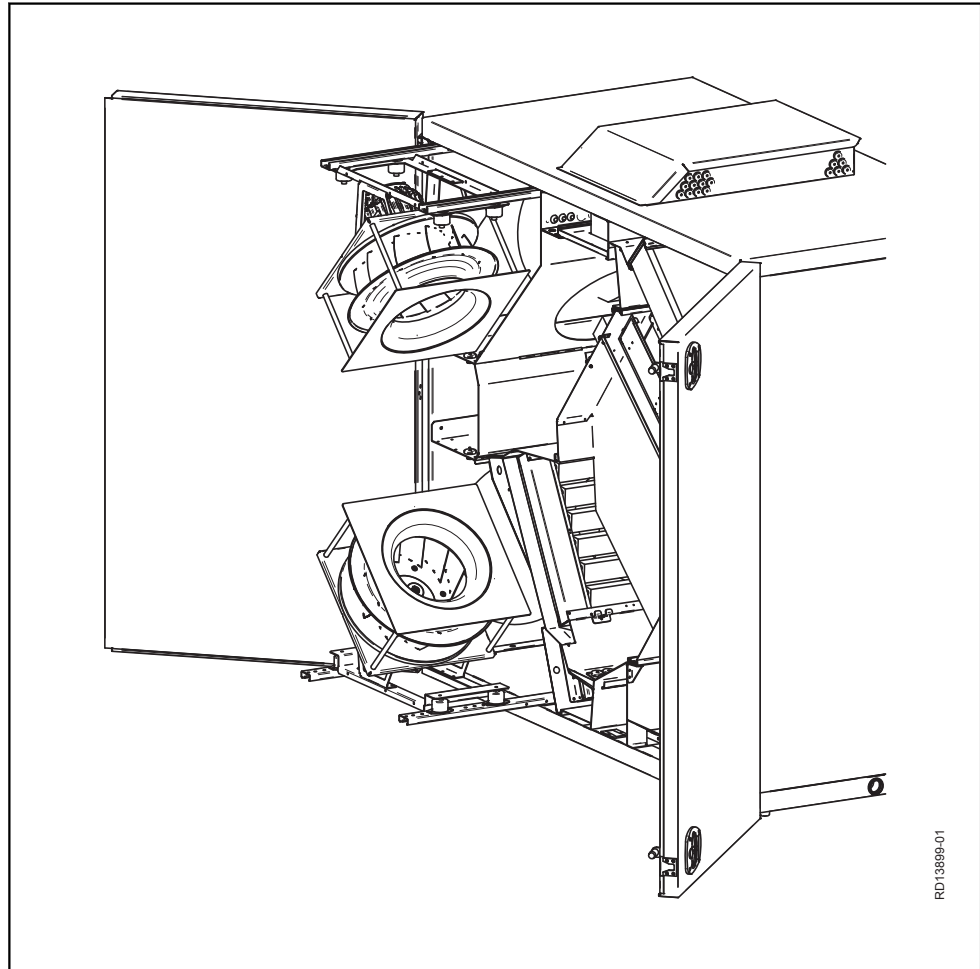

Step	Action
1	Remove the fixing screw from the sliding rail, and release the ties on the motor cable.
2	Pull the fan unit out to the stop (two screws) on the sliding rail.
3	Dismount the motor cable from the motor control on the sliding panel and pull it towards the motor through the rubber grommets.
4	Remove the two sliding rail screws. The fan unit can now be lifted off.



Vertical VEX

To remove the fan unit

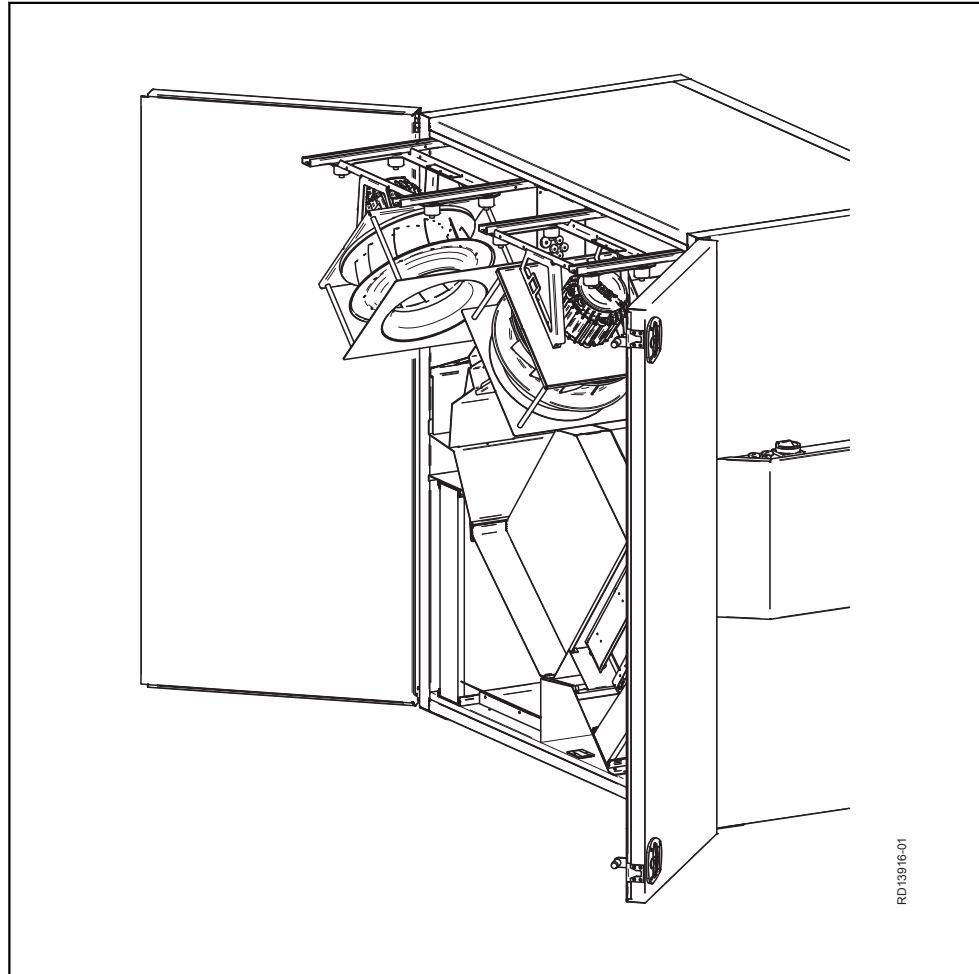

Step	Action
1	Remove the fixing screw from the sliding rail, and release the ties on the motor cable.
2	Pull the fan unit out to the stop (two screws) on the sliding rail.
3	Dismount the motor cable from the motor control on the sliding panel and pull it towards the motor through the rubber grommets.
4	Remove the two sliding rail screws. The fan unit can now be lifted off.

Removal

See section "Maintenance" for instructions for dismounting fans and counterflow heat exchanger and for removal of filters.



3. Mechanical assembly

3.1 Installation of Horizontal and Vertical VEX

Description It is important that the VEX is installed on a level surface, as this affects the collection and draining of the condensate.

3.1.1 Installation directly on floor

The requirements for the floor surface must be met, see the section entitled "Requirements for underlying surface".

NB After installation, check the VEX unit is completely level.

3.1.2 Installation on mounting base

The EXHAUSTO mounting base enables the VEX unit to be installed correctly. The base is equipped with adjustable levelling screws, so that the air handling unit can be fitted horizontally on a surface that is not level (+/- 20 mm per metre). See the separate instructions for installing the mounting base.

3.2 Condensation outlet



Drain the condensation outlet into a floor gully or similar. The condensation outlet must be fitted with a water trap. See below.

Risk of frost



Where there is a risk of frost: Insulate the condensation outlet and protect it against frost - if necessary, using a heating cable.



Connection of the condensation outlet must be made by an authorised plumber.



Drain the condensation outlet into a floor gully or similar. The condensation outlet must be fitted with a water trap. See below.

Risk of frost



Where there is a risk of frost: It is recommended to protect the condensation outlet against frost damage. Fit a SIPHONE electrical heat tracing device on the outlet before the pipes are insulated. For fitting, see the device's fitting instructions.

3.2.1 Establishment of condensation outlet

Location The following two drawings show examples of how the drain from the condensation outlet can be established and the correct dimensions for the water trap:

Solution with siphon water trap (accessory)

The siphon water trap is easy to install and service.

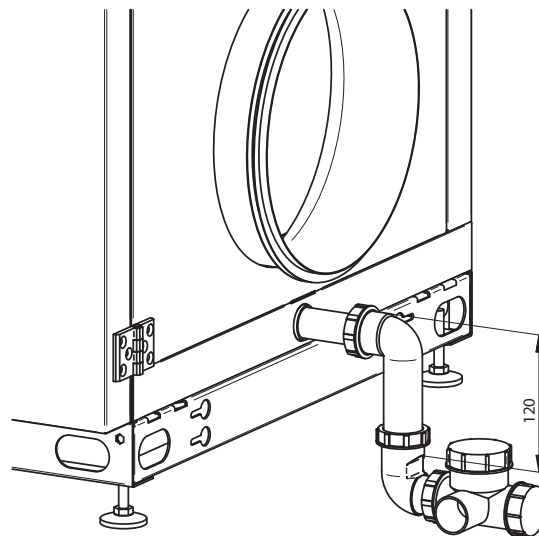

Solution with HT pipe

Use HT pipe (HT, DN32, DIN4102), if the above solution is not employed (not supplied by EXHAUSTO).

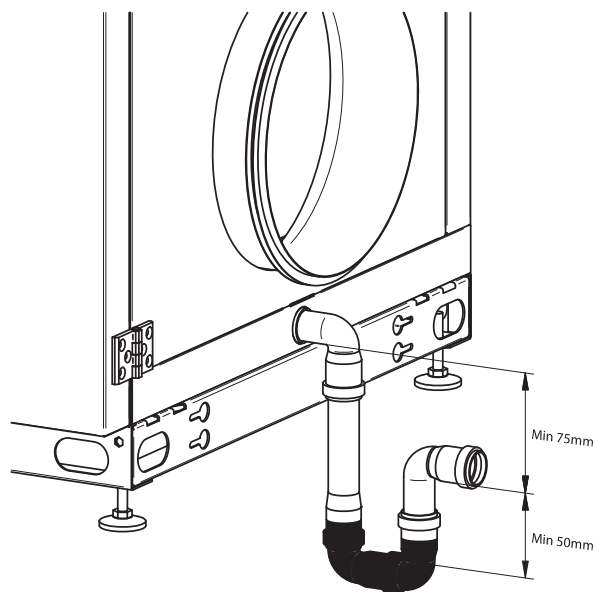

NB:

If the VEX is erected on a mounting base, this will allow sufficient free height for installing a water trap.



3.3 Water heating coil

3.3.1 Principles for connecting the water heating coil

Mixing loop

The diagrams below are simplified. The dimensioning of valves, pipes, etc. and heating coil connection must always be carried out by authorised fitters in accordance with applicable regulations and legislation.

Type	Method	Simplified diagram
Mixing loop 1	Variable flow in the primary circuit (supply) and constant flow in secondary circuit (VEX unit)	
Mixing loop 2	Constant flow in the primary circuit (supply) and the secondary circuit (VEX unit) a) When there is no heating requirement, valve adjustment must be based on the required primary circuit water flow	
	<p>Do not connect the heating coil like this!</p> <p>Connection without circulation pump risks frost damage!</p>	

RD12842-02

RD12800-03

Explanation of simplified diagram

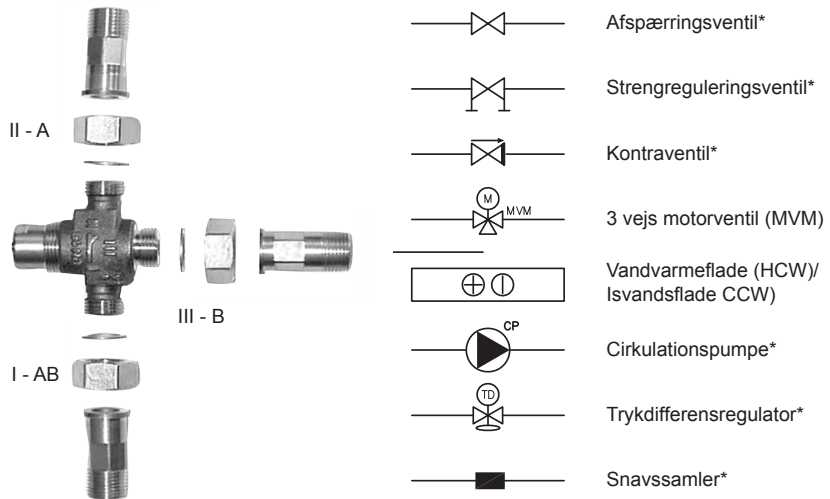

RD12642DK-02

*) not EXHAUSTO delivery (refer to the technical specifications).

Insufficient bleeding



Insufficient bleeding can result in still water forming in the system, which may result in frost-induced leaks during the winter.

Fitting motor valve



The valve must not be fitted with the motor facing down

Insulate the supply pipe and heating coil



The pipes and heating coil must be insulated according to applicable regulations

3.3.2 Bleeding of coils

Bleeding

It is the responsibility of the contractor/customer to ensure that the bleeding option is correctly installed and that the building owner is informed of the risk of insufficient bleeding, regardless of whether the coil(s) in question are built into a ventilation system or mounted separately in the duct system.

The following must be observed when bleeding liquid-coupled coils/heating and cooling batteries:

- The heating/cooling system must be arranged in accordance with DS469 so that they can be bled.
- Ventilation systems installed above suspended ceilings or outside on roofs are often the top point of the pipe system and therefore air is often collected in the system here.
- Bleeding points must be easily accessible.
- Bleeding points must be selected so that all air in the system can be bled.
- Air pots and automatic air vents should be considered so that air is collected before it enters the coils, despite the fact that many coils are equipped with a bleeding option.
- A lack of bleeding can lead to a lack of water flow and, ultimately, frost damage to the coils and subsequent water damage to the building.

Following connection of water supply to the unit:

- Bleed the system thoroughly using the upper bleed screw on the water coil.



3.3.3 MVM valve

Definition

MVM is used as a general term for an engine valve.

Screening

Screen the valve motor from direct sunlight. Due to heat emissions, the valve motor must not be encapsulated (max. ambient temperature: 50°C).

Insulating the valve

To ensure normal operation at ambient temperatures below 0°C, it is very important that the valve section is insulated according to current standards/procedures.

MVM-OD, valve for outdoor fitting

If MVM-OD (MVM intended for outdoor fitting) is used, the screening and insulation are part of the delivery. MVM-OD is only possible for valve sizes below 6.3 K_{VS}.

Regulating properties

Optimal regulation is achieved when the differential pressure is between 5–20 kPa. See section "Technical specifications" to calculate K_{VS}.

Heat supply

The heat supply **must** be constant.



4. Electrical installation

4.1 Electrical installation

See the attached instructions "Guide to Electrical Installation of VEX150-X with water heating coil".



5. Maintenance, hygiene and servicing

5.1 Maintenance

***Filters**



Only use original EXHAUSTO filters

- The provided filter data (section "Technical data") are based on the use of original EXHAUSTO filters
- Eurovent certification is only valid if original filters are used.
- Use of non-original filters may cause leakage in the VEX unit, impair filter function and cause an extraordinary pressure drop.
- EXHAUSTO recommends that you register the filter replacement date to ensure filters are replaced at the correct intervals.

5.1.1 Overview of maintenance intervals

The following chart details the recommended maintenance intervals for the VEX. The intervals are a guide and based on normal operation. EXHAUSTO recommends maintenance is adjusted to match the actual operating requirements.

Component	Procedure	Twice a year	Once a year
Filters*	<p>Filter replacement: Recommended that both filters are replaced at the same time.</p> <p>Filters should be replaced at least:</p>	X	
Filter monitor	Check that all the seals in the filter monitor are tight.		X
Seals and sealing strips	Check that all the seals are tight.		X
Fan	<ul style="list-style-type: none"> • Check that the fan impeller is securely fixed to the shaft. Removal of fan unit. See section "Internal transport with reduced weight" • Cleaning. See section "Servicing and cleaning" 		X
Counterflow heat exchanger	Clean the heat exchanger. See section "Cleaning of counterflow heat exchanger"		X
Bypass damper	Check damper function		X
Heating coil	Clean the heating coil. See section "Cleaning of heating coil"		X
Closing damper	Check damper function		X
Condensation outlet	Check that the outlet functions by pouring water in the condensation tray		X
Motor valve/circulation pump	Check function		X

5.2 Hygiene (VEX100VDI only)

VDI6022 air hygiene standard

To ensure that the VEX100 meets the requirements of the VDI6022 hygiene standard, its design ensures that:

- bacterial growth and dirt accumulation are minimal
- conditions for cleaning are optimum

Filter ePM₁ 55%

The outdoor air side of the unit must as a minimum be fitted with an ePM₁ 55% filter (F7) to meet VDI 6022 requirements.

5.3 Servicing and cleaning

5.3.1 Filter replacement



Disconnect power at the isolation switch before opening the door.

Pull the filters out. Remember to check the flow direction - see the arrows on the filter.
Discarded filters must be stored immediately in sealed plastic bags and disposed of responsibly.

5.3.2 Cleaning the fans

Step	Action
1	Switch off the power supply to the air handling unit at the isolation switch before opening the doors.
2	Pull out the fan section: Loosen the fixing screw on each sliding rail and loosen the bindings on the motor cables. Pull the fan unit out to the stop (two screws) on the sliding rails.
3	Clean the fan impeller with a vacuum cleaner and wipe down with a damp cloth if necessary. Clean the blades on the fan impeller carefully to avoid disrupting the balance. If there are weights on the fan impeller, these must not be removed.
4	After cleaning the fan impeller, check that the unit does not vibrate when operating.
Checking measuring socket hoses	
5	Remove the hoses at the measuring sockets.
6	Blow air through the hoses to remove any impurities.

5.3.3 Cleaning the heating coils

Step	Action
1	Switch off the power supply to the unit at the isolation switch before opening the doors.
2	Vacuum clean the heating coil
3	Check that the fins on the heating coil are not deformed.  The fins are sharp.

5.3.4 Removing and cleaning the counterflow heat exchangers

Warnings



Disconnect power at the isolation switch before opening the doors.



Take care, as the counterflow heat exchanger is heavy - (see weight under Technical Data)



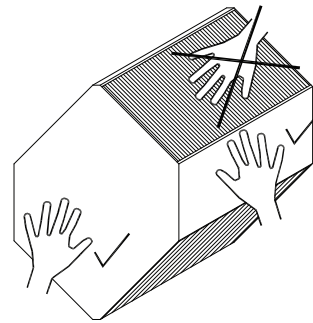

The counterflow heat exchanger fins can be easily damaged - avoid contact with the fins when handling.

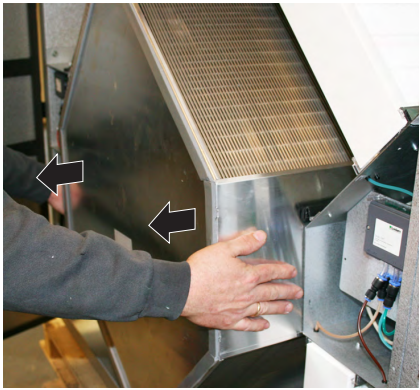

5.3.5 Cleaning the counterflow heat exchanger

Step	Action	
1	Remove the plug from the bypass motor. Hold down the split pin under the plug using a screw driver as shown on photo Then remove the plug	
2	Carefully remove the bypass (do not wrench it out)	
3	Make sure the Tice sensor/fitting is free of the counterflow heat exchanger before extracting it.	

Step	Action	
4	Remove the counterflow heat exchanger all the way. Note the weight of the heat exchanger, see technical data – min. two people when lifting.	
5	Clean the counterflow heat exchanger by flushing with hot water or by pressure hosing. Max. water temperature 90°C.	
6	Replace the counterflow heat exchanger and then the bypass. Check that the Tice sensor is correctly positioned between the heat exchanger fins, as the sensor will not measure correctly otherwise.	
7	Re-insert the plug for the bypass motor.	

5.4 Airflow measurement

5.4.1 Determining airflow and pressure

Use the formulae in the table to calculate airflow and pressure drop over the filters.

Airflow:	Airflow q_V (l/s, m ³ /h) can be read from the differential pressure Δp_M [Pa]
Extract air	$\Delta p_{M1.2} = P_{1.2X} - P_{1.2Y}$ [Pa]
Supply air	$\Delta p_{M2.2} = P_{2.2X} - P_{2.2Y}$ [Pa]

Pressure drop across:	
Extract air filter	$\Delta p_{1.1} = P_{1.1X} - P_{1.1Y}$ [Pa]
Supply air filter	$\Delta p_{2.1} = P_{2.1X} - P_{2.1Y}$ [Pa]

Location of measurement points

The location of measurement points is shown on the drawing. The exterior measuring points positions on the VEX are shown in the drawings in the section "Description".

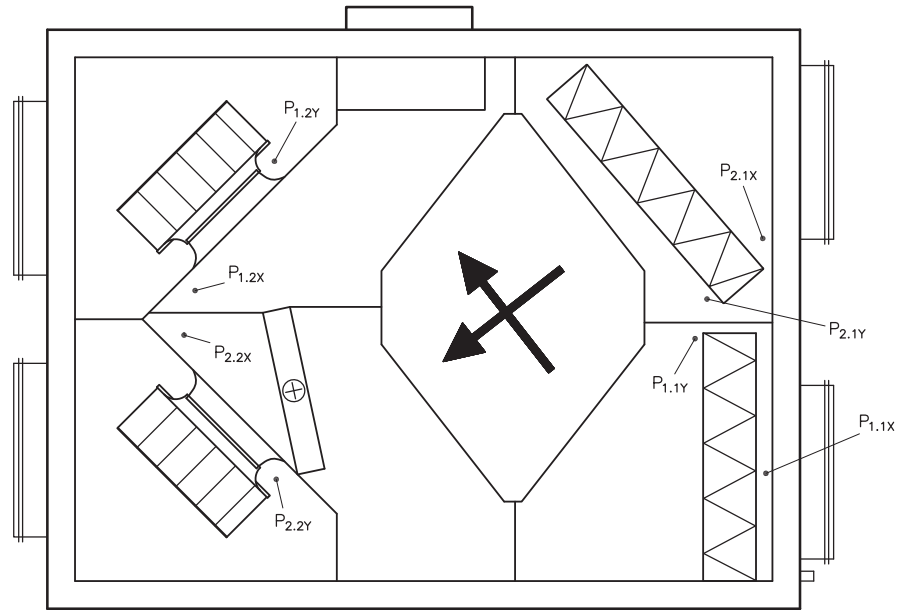

5406596-01

Supply air

Supply airflow diagram:

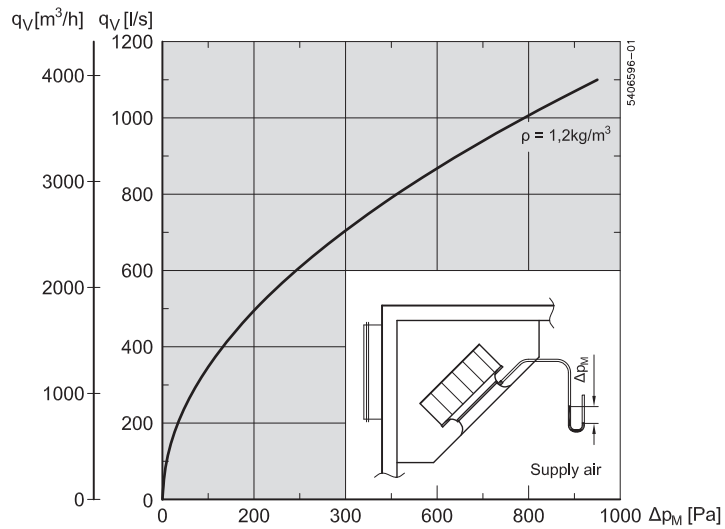

— Airflow (q_v) according to pressure difference (Δp_M)

$$\left. \begin{aligned} q_v &= 98,64 \cdot \sqrt{\frac{2 \cdot \Delta p_M}{\rho}} \text{ [m}^3/\text{h]} \\ q_v &= 27,4 \cdot \sqrt{\frac{2 \cdot \Delta p_M}{\rho}} \text{ [l/s]} \end{aligned} \right\} \pm 10\% \text{ for } \Delta p_M > 40 \text{ Pa}$$

Extract air

Extract airflow diagram:

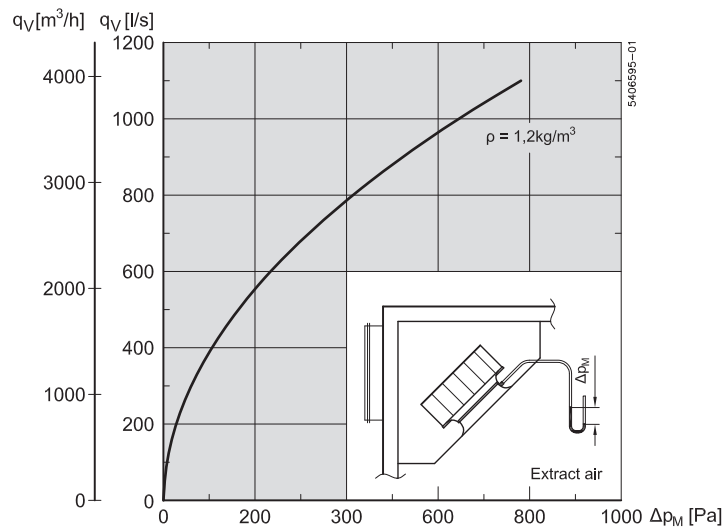

— Airflow (q_v) according to pressure difference (Δp_M)

$$\left. \begin{aligned} q_v &= 109,8 \cdot \sqrt{\frac{2 \cdot \Delta p_M}{\rho}} \text{ [m}^3/\text{h]} \\ q_v &= 30,5 \cdot \sqrt{\frac{2 \cdot \Delta p_M}{\rho}} \text{ [l/s]} \end{aligned} \right\} \pm 10\% \text{ for } \Delta p_M > 40 \text{ Pa}$$



6. Technical data

6.1 Weight, corrosion class, temperature ranges, etc.

Weight

VEX total weight	330 kg
Doors	2 x 26 kg
Counterflow heat exchanger	31 kg
Fan unit	2 x 20 kg
VEX for internal transport (without doors, heat exchanger and fan unit)	247 kg

Corrosion class

Corrosion class	Corrosion class C4 in accordance with EN ISO 12944-2
-----------------	--

Temperature ranges

Outdoor air temperature	-40°C to +35°C
Ambient temperature	-30°C to +50°C

At temperatures below -25°C (with outdoor installation), use of a thermostatically controlled heater in the automated control box is recommended.

Motor damper

Motor damper type	LS (closing damper)	LSR (closing damper, spring return)
Type	LS400-24	LSR400-24
Designation	LSA/LSF	LSFR
Motor type	NM24-F	AF-24
Rotation time	75–150 s	open: 150 s close: 16 s
Ingress protection	IP42	IP42
Ambient temperature	-20°C to +50°C	-30°C to +50°C
Damper depth	100 mm	100 mm

6.2 Panel filters

Data	VEX150		Device
	ePM ₁₀ 50%	ePM ₁ 55%	
Dimensions: h x w, 1 item per air direction	577 x 732		mm
Panel filter thickness	96		mm
Temperature resistant to	70		°C
Filter class according to ISO 16890	ePM ₁₀ 50%	ePM ₁ 55%	
Filter class according to EN 779	M5	F7	

Final pressure drop

For the final pressure drop over the filter, the lower of the following two methods is recommended.

- Final pressure drop = 3 x initial pressure drop
 - Final pressure drop = initial pressure drop + 100 Pa
-

6.3 Water heating system

Water heating coil

		HCW
Weight	Weight without fluid	8.7 kg
	Water content	2.2 l
Dimensions	Face area (h x b)	425 x 655 mm
Data	Test pressure	3000 kPa
	Max. operating pressure	1000 kPa
	Number of rows of pipes	qty. 2
	Number of circuits	qty. 5
	Pipe connection	DN15 (½")
	Fin spacing	2.1 mm
	Permissible media temperature	5..0.95°C

Recommendation

A precise calculation of the heating coil is recommended, to be carried out with calculation program EXselect, available on www.exhausto.dk.

6.4 Capacity diagram



Recommendation

You are recommended to make a more precise calculation of the unit's capacity with the EXselect calculation program, **EXSELECTPRO**  available on the EXHAUSTO website.

6.5 EC Declaration of Conformity

The document is located in the door of the VEX unit. It is also available on the EXHAUSTO website by searching under the document or order number.

6.6 Ordering spare parts

Find production number

When ordering spares, please state the relevant production part number. This will ensure that the correct parts are delivered. The production number is given on the front of the VEX guidelines and on the VEX rating plate.

Contact:

Contact your local EXHAUSTO office service department to order a spare part. Contact information is given on the back cover of these instructions. See also the "Layout" section for an overview of the position and designation of parts in the VEX.

6.7 Environmental declaration

Environmental documentation

The unit can be disassembled into individual product parts when worn out and in need of disposal.

Product parts	Material	Handling
Sheet parts	Aluzinc	Recycle after disassembly
Condensation tray	Stainless steel	Recycle after disassembly
Bypass dampers, heat exchangers and metal sections	Aluminium	Recycled
Insulation	Mineral wool	Recycle after disassembly
Door gasket	CFC and HCFC-free cellular rubber	For landfill waste or incineration
Fan motors, bypass motors	Aluminium, steel, copper and plastic	Recycle after disassembly
Control unit	Electronic components	Recycle via an authorised enterprise
Panel filters	Fibreglass and plastic	For landfill waste or incineration
The air handling unit is supplied on disposable pallets	Wood	For landfill waste or incineration

Percentage weight

Handling	Percentage weight of materials per unit
Recycled	11% (mineral wool)
Recycled	85% (63% Aluzinc, 16% aluminium, 3.5% steel/iron, 2% stainless steel and 1% copper)
For landfill waste or incineration	2% (Wood, filter paper, cellular rubber)
Other	1.5% (electronic components)
Total	100%



Scan code and go to addresses at
www.exhausto.com