





GB

# VEX160CF Horizontal HCW

with EXact2 control



	Product information.....	Chapter 1 + 6
	Mechanical assembly.....	Chapter 2 + 3
	Electrical installation.....	Chapter 4
	Maintenance.....	Chapter 5

Original instructions



## 1. Product information

<b>1.1. Designations used in these instructions</b> .....	<b>5</b>
1.1.1. Simplified diagram.....	5
<b>1.2. Application</b> .....	<b>6</b>
<b>1.3. Location requirements</b> .....	<b>6</b>
1.3.1. Space requirements.....	6
1.3.2. Requirements for underlying surface.....	6
1.3.3. Condensation outlet.....	6
1.3.4. Requirements for duct system.....	7
<b>1.4. Description</b> .....	<b>8</b>
1.4.1. VEX unit construction.....	8
1.4.2. Parts of the VEX unit.....	9
<b>1.5. Principal dimensions</b> .....	<b>9</b>



## 2. Handling

<b>2.1. Unpacking</b> .....	<b>12</b>
2.1.1. Once the VEX has arrived .....	12
<b>2.2. Transport</b> .....	<b>12</b>
2.2.1. Passage through openings.....	13
2.2.2. Internal transport with reduced weight.....	14



## 3. Mechanical assembly

<b>3.1. Installation</b> .....	<b>16</b>
3.1.1. Installation directly on floor.....	16
3.1.2. Installation on mounting base.....	16
<b>3.2. Condensation outlet</b> .....	<b>16</b>
3.2.1. Establishment of condensation outlet.....	16
<b>3.3. Water heating coil</b> .....	<b>18</b>
3.3.1. Principles for connecting the water heating coil.....	18
3.3.2. Bleeding of coils.....	19
3.3.3. Bleeding of coils.....	19
3.3.4. MVM valve.....	20



## 4. Electrical installation

<b>4.1. Electrical installation</b> .....	<b>22</b>
---	-----------



## 5. Maintenance, hygiene and servicing

<b>5.1. Operating readings via the HMI panel</b> .....	<b>23</b>
<b>5.2. Maintenance</b> .....	<b>23</b>
5.2.1. Overview of maintenance intervals.....	23
<b>5.3. Hygiene (VEX100VDI only)</b> .....	<b>24</b>
<b>5.4. Servicing and cleaning</b> .....	<b>24</b>
5.4.1. Filter change.....	24
5.4.2. Cleaning the fans.....	24
5.4.3. Cleaning the heating coils.....	24
5.4.4. Removing and cleaning the counterflow heat exchangers.....	24
5.4.5. Cleaning the counterflow heat exchanger.....	25



## 6. Technical data

<b>6.1. Weight, corrosion class, temperature ranges, etc</b> .....	<b>27</b>
<b>6.2. Panel filters</b> .....	<b>28</b>
<b>6.3. Water heating system</b> .....	<b>29</b>
6.3.1. MVM motor valve .....	29
<b>6.4. Capacity diagram</b> .....	<b>29</b>
<b>6.5. EC Declaration of Conformity</b> .....	<b>29</b>
<b>6.6. Ordering spare parts</b> .....	<b>30</b>
<b>6.7. Environmental declaration</b> .....	<b>30</b>

## Symbols, terms and warnings

### Prohibition symbol



Failure to observe instructions marked with a prohibition symbol may result in serious or fatal injury.

### Danger symbol



Failure to observe instructions marked with a danger symbol may result in personal injury and/or damage to the unit.

### Scope

This instruction manual is for use with EXHAUSTO VEX-type air handling units. Please refer to the product instructions regarding accessories and extra equipment.

The instructions must be fully observed to ensure personal safety and to protect the equipment and ensure its correct operation. EXHAUSTO A/S accepts no liability for accidents caused by equipment not used in accordance with the manual's instructions and recommendations.

### Supply air/extract air

This instruction manual uses the following terminology:

- Supply air
- Extract air
- Outdoor air
- Exhaust air

### Accessories

The confirmation of order states which accessories are delivered with the VEX unit.

### Definition

In the type designation R stands for Right, indicating that the supply air is to the right of the unit, as seen from the operating side. Supply air to the left is designated with L for Left

### Warnings

#### Opening the air handling unit



Do not open the service doors until power has been disconnected at the isolation switch and the fans have stopped.

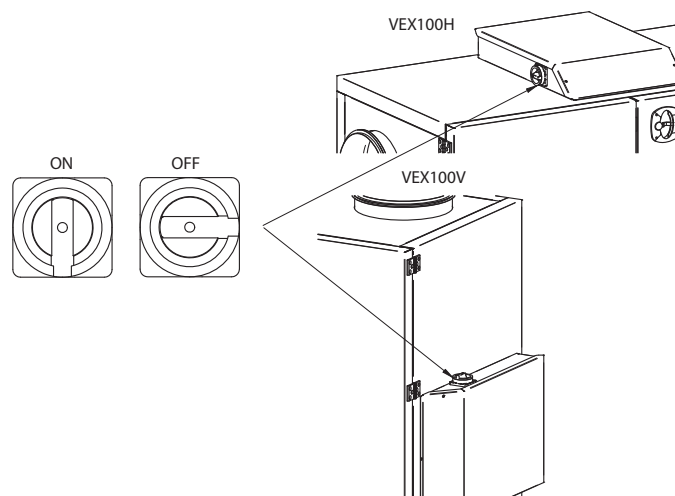

RD13318-01

### Lock the air handling unit during operation

The VEX unit must always be locked during operation:

- Use the cylinder lock in the handle. **Remember** to remove the key from the lock.
- Or use a padlock. Use the handle's built-in padlock fixture

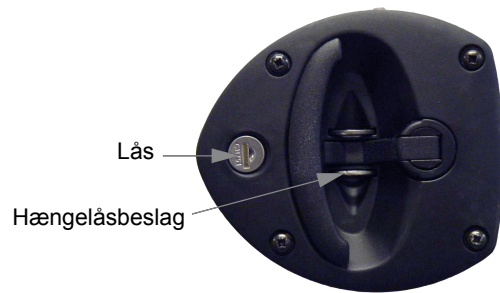

### Information plate

The VEX unit rating plate shows:

- VEX unit, type (1)
- production number (2)

EXHAUSTO		CE	
Type	V150CFHLECW2	←	1
No./Year	2406294/2017	←	2
Supply	Voltage: 3x400V+N+PE ~50Hz	Current: 15A	
Heat	HCW		
FAN ECO design	$\eta = 60,0\%$ (A) N62 (2015) N = 74.4 VSD integrated		

**NB:**

Always have the production number ready when contacting EXHAUSTO A/S.

## Choose the correct documentation for the task...

Find your information.

Supplied documentation	Assembly and installation instructions	Electrical installation guide	EXact2 Basic instructions	EXact2 menu guide	Print out from calculation program
Mechanical assembly »	✓				✓
Electrical installation »		✓			✓
Start-up - operation »			✓	✓	✓
Maintenance - Service »	✓	✓	✓	✓	✓



## 1. Product information

### 1.1 Designations used in these instructions

#### 1.1.1 Simplified diagram

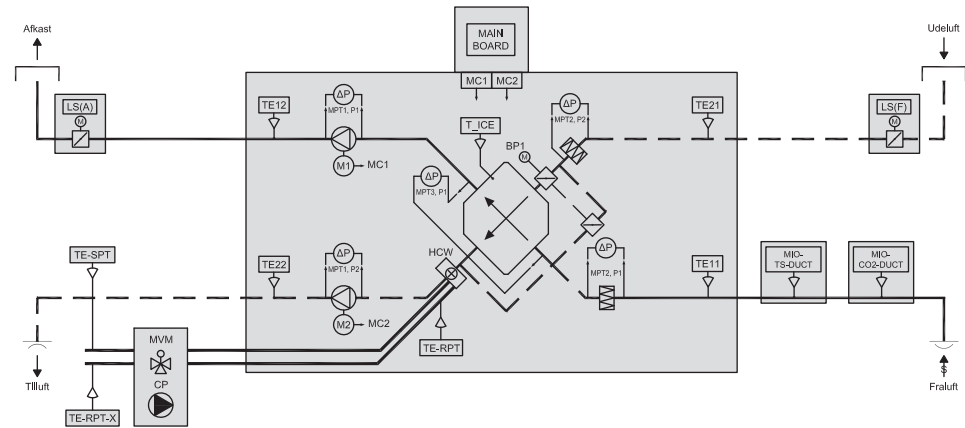

RD113006K42

Component	Function	Standard/accessory
HCW	Water heating coil	Standard
TE-RPT	Temperature sensor in return pipe from water heating coil (internal)	Standard
MPT1, P1	Airflow control, extract air	Accessories
MPT1, P2	Airflow control, supply air	Accessories
MPT2, P1	Filter monitor, extract air	Accessories
MPT2, P2	Filter monitor, outdoor air	Accessories
MPT3, P1	Ice detection	Accessories
LS(F)/LS(F)R	Closing damper, outdoor air	Standard
LS(A)/LS(A)R	Closing damper, exhaust air	Accessories
BP1	Bypass damper	Standard
M1	Extract air motor	Standard
M2	Supply air motor	Standard
MC1	Motor controller, motor 1	Standard
MC2	Motor controller, motor 2	Standard
TE11	Temperature sensor, extract air	Standard
TE12	Temperature sensor, exhaust air	Standard
TE21	Temperature sensor, outdoor air	Standard
TE22	Temperature sensor, supply air	Standard
T <sub>ice</sub>	Temperature sensor for ice in exchanger	Standard
Main Board	Connection box for MVM, CP and TE-RPT-X and TE-SPT	Standard
MVM	Motor valve	Accessories
CP	Circulation pump	Accessories
TE-SPT	Temperature sensor on feed pipe to the heating coil	Standard
TE-RPT-X	Temperature sensor on external pipeline from water heating coil	Accessories

## 1.2 Application

**Comfort ventilation** EXHAUSTO VEX is used for comfort ventilation tasks.  
Operating temperature range for the unit – see section "Technical data".

**Prohibited uses** The VEX unit is not to be used to transport solid particles or in areas where there is a risk of explosive gases.

## 1.3 Location requirements

**Positioning** The unit is designed for indoor fitting. The unit can be ordered for outdoor fitting, in which case it is provided with a roof (accessory VEX100OD).

### 1.3.1 Space requirements

The drawing below indicates how much space is needed for opening the doors and servicing the unit, e.g. changing filters, cleaning, servicing, etc.

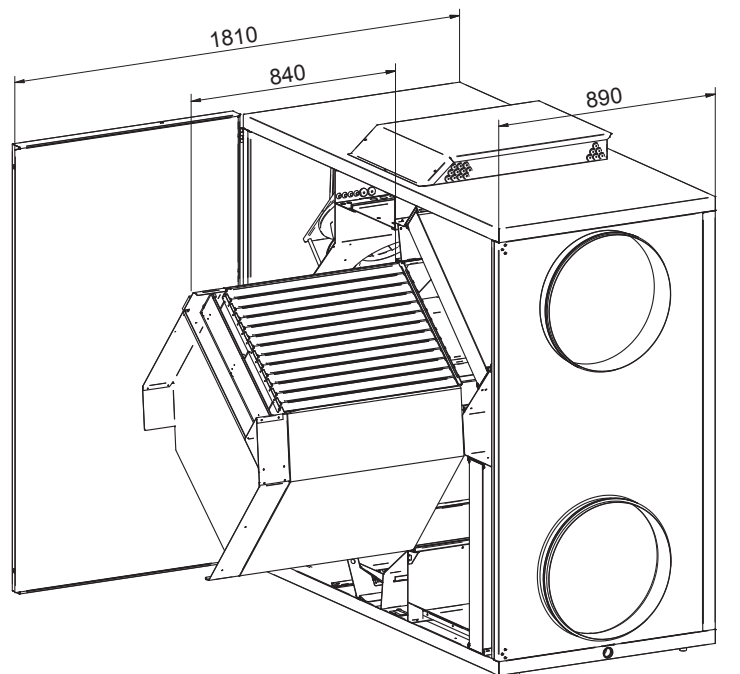

**NB:** For servicing, the VEX must have a free height of at least 300 mm above the connection box.

### 1.3.2 Requirements for underlying surface

When fitting the unit directly to an existing surface - i.e. without using the mounting base (accessory) - the surface must be:

- flat
- level (+/- 3 mm per metre)
- hard
- resistant to vibration

### 1.3.3 Condensation outlet

A condensation outlet must be installed in the immediate vicinity of the unit. See also "Mechanical assembly" section.

### 1.3.4 Requirements for duct system

#### Silencers

The duct system must be fitted with silencers specified by the Project Manager, which meet the requirements of the operating area.

#### Bends

A duct bend may be fitted immediately after the unit, because the airflow in the spigot has a uniformly moderate speed profile, which results in negligible system pressure loss.

#### Insulation



The duct system must be insulated against:

- condensation
- sound leakage
- heating/cooling losses

#### Condensation

Condensation in the ducts may occur when the exhaust/outdoor air has high humidity. EXHAUSTO recommends a condensation outlet is also fitted at the lowest point in the ducts.

#### Outdoor air intake

The outdoor air intake must be dimensioned with sufficiently low airflow to prevent rain and snow being drawn into the duct system.

#### No duct connection



If one or more of the spigots is not connected to a duct: Fit a protective net to the spigots with a maximum mesh width of 20 mm.

## 1.4 Description

### 1.4.1 VEX unit construction

The following drawings show an overview of the construction of left and right-hand models of VEX units (shown without doors).

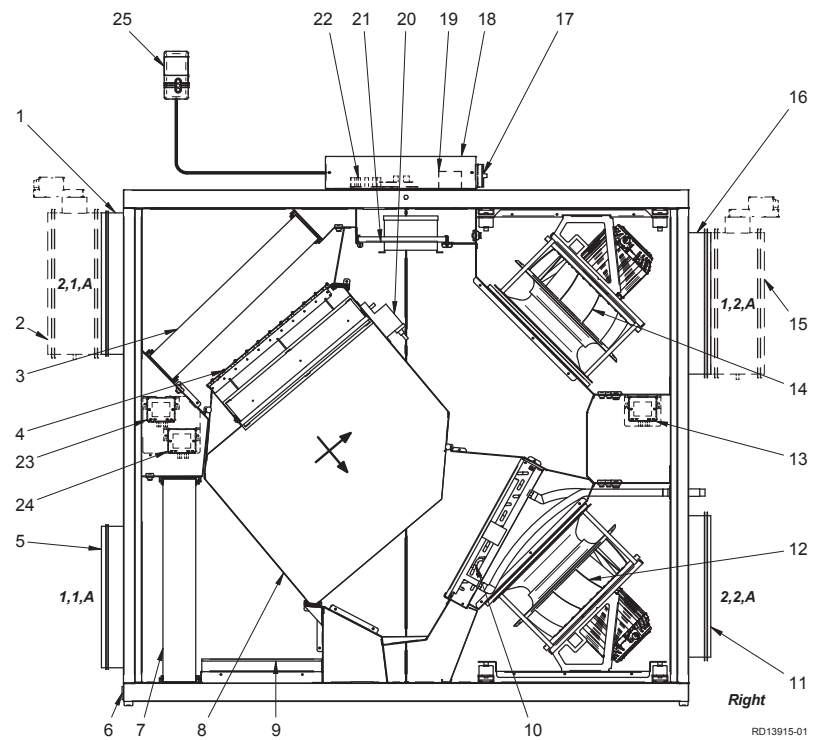
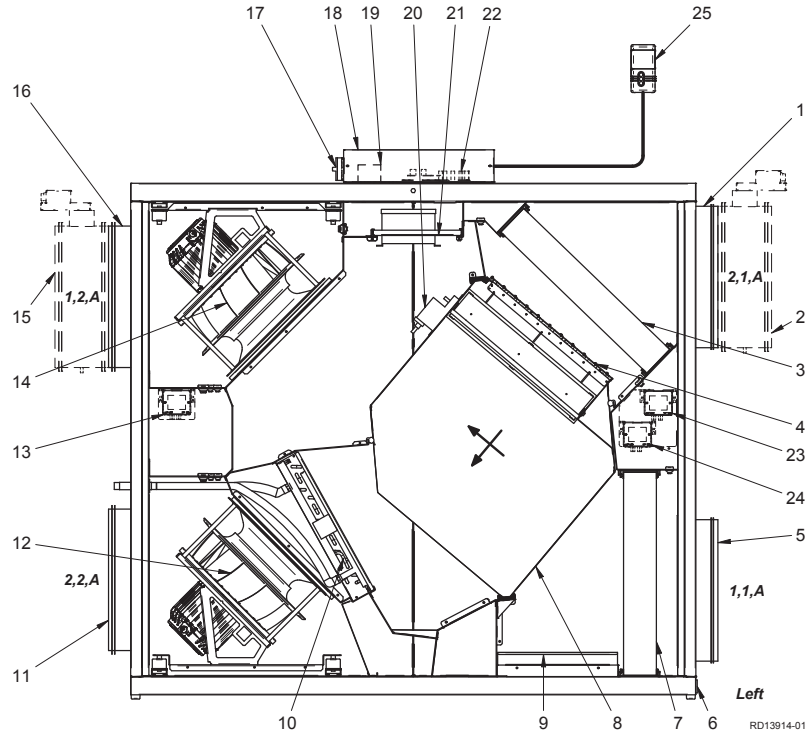



Pos.	Part	Function
1	Spigot 2.1.A	Outdoor air spigot The spigot can also be positioned on the top of the air handling unit (2.1.B)
2	Closing damper LS	LSF, outdoor air closing damper
3	Outdoor air filter	Filters outdoor air.
4	Bypass damper	For operation with heat recovery, the bypass damper is closed so that the air passes through the counterflow heat exchanger. For bypass operation, the damper is open, and the air bypasses the heat exchanger.
5	Spigot 1,1,A	Extract air spigot
6	Condensation outlet	Channels condensate to the drain.
7	Extract air filter	Filters extract air.
8	Counterflow heat exchanger	Conducts heat from extract air to supply air.
9	Condensation tray	Collects the condensate and drains it away from the counterflow heat exchanger to the condensation outlet
10	Water heating coil with bleed screw	Heats supply air if heat recovery is insufficient.
11	Spigot, 2,2,A	Supply air spigot. The spigot can also be positioned at the bottom of the air handling unit (2.2.B).
12	Supply air fan	For outdoor air/supply air.
13	MPT1 (AFC)	Airflow control (accessory).
14	Extract air fan	For exhaust/extract air.
15	Closing damper LS	Closing damper, exhaust air, LSA (accessory).
16	Spigot 1,2,A	Extract air spigot The spigot can also be positioned on the top of the unit (1.2.B).
17	Isolation switch	Connects/disconnects current.
18	Connection box	Connection of accessories.
19	Terminal row	Connection of accessories to ventilation unit.
20	Bypass motor	Opens/closes bypass damper.
21	Extraction plate	Positioning of motor control components.
22	EXact2 control	Control system.
23	MPT3 (DEP)	Ice detection - measurement of pressure in supply air duct (accessory)
24	MPT2 (MPTF)	Filter monitor (accessory).
25	HMI panel	Control panel.

#### 1.4.2 Parts of the VEX unit

##### Cabinet

The inside and outside of the cabinet are made of Aluzinc® The cabinet has been insulated with 50 mm mineral wool.

##### Fans

The unit contains two centrifugal fans with backward curved blades for extract air and supply air.

##### Counterflow heat exchanger

The counterflow heat exchanger in the unit is mounted with a modulating bypass damper. The counterflow heat exchanger can be removed and cleaned.

##### Filters

The unit includes integral panel filters for both extract air and supply air.

## 1.5 Principal dimensions

##### VEX160H, Left

The following drawing gives the principal dimensions:

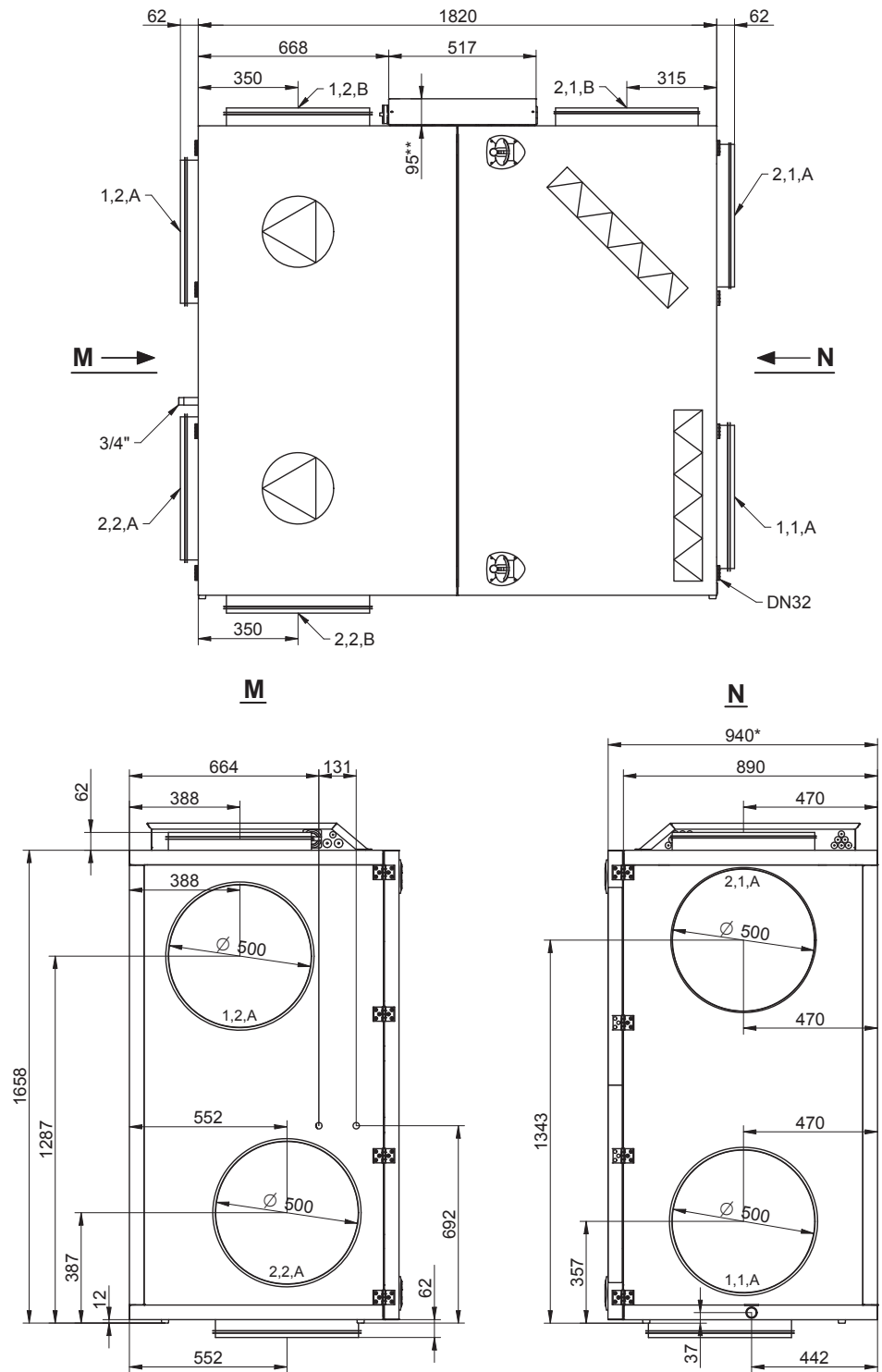

RD13908-01

**NB:** The drawing shows all of the spigot positioning options.  
 \* Allow a distance for service in front of the unit equivalent to the unit depth.  
 \*\* Allow a min. of 300 mm free height for service.

**VEX160H, Right** The following drawing gives the principal dimensions:

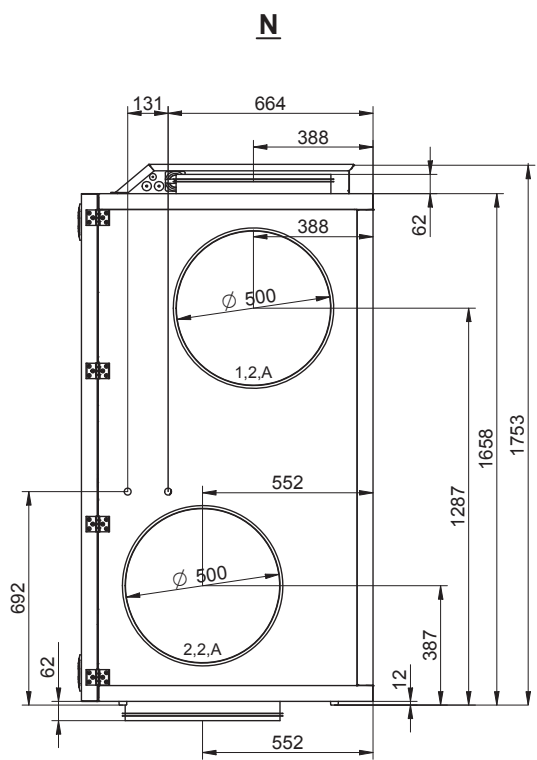
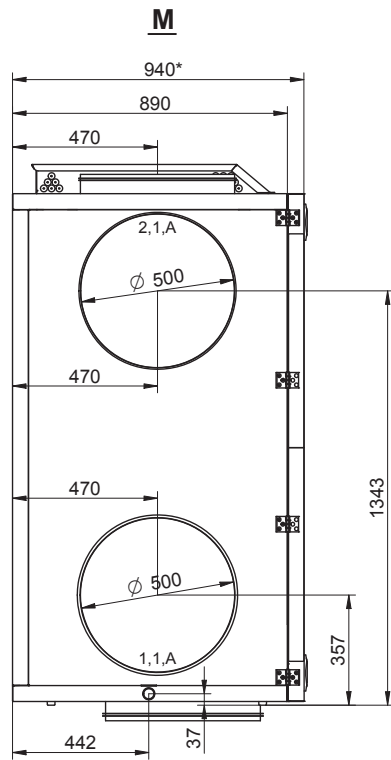
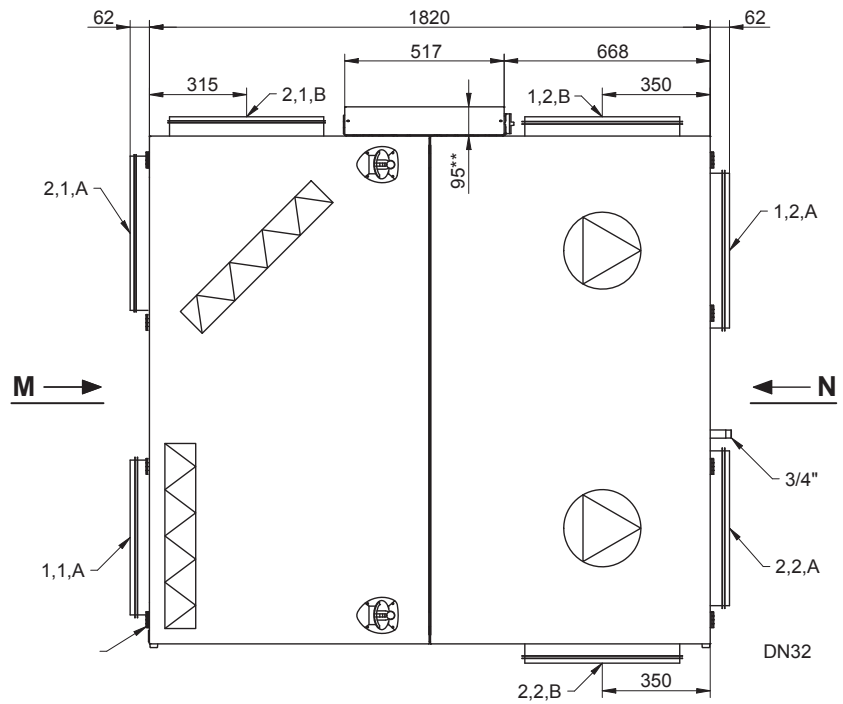

RD13909-01

**NB:**

The drawing shows all of the spigot positioning options.

\* Allow a distance for service in front of the unit equivalent to the unit depth.

\*\* Allow a min. of 300 mm free height for service.



## 2. Handling

### 2.1 Unpacking

#### 2.1.1 Once the VEX has arrived

- Check the air handling unit and any supplied accessories for any transport damage immediately on arrival at the assembly site.
- Check that the delivery is complete.



If there is damage or something is missing, point this out immediately to the haulier.

#### Delivery

The following components are supplied:

- VEX unit
- Accessories supplied

#### Packaging

The unit is delivered on a disposable pallet and packed in clear plastic.

#### NB

Once the plastic has been removed, the unit must be protected against dirt and dust:

- The covers on the spigots must not be removed until the spigots are connected to the ventilation ducts.
- Whenever possible, keep the unit closed during fitting.

#### The unit should be cleaned before it is used.

Once the VEX unit is fitted, it must be checked and thoroughly cleaned. All dust, debris and metal shavings must be vacuumed up.

### 2.2 Transport



#### Transport

Transport the VEX unit on the disposable pallet. Do not lift it with the spigots or connection box.

#### Transport methods

Transport the VEX unit in one of the following ways:

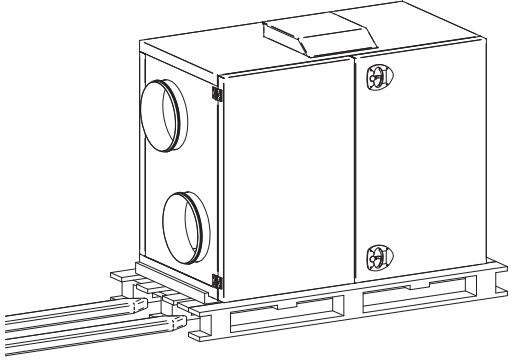
Method	Drawing
<p>Manual transport: Lifting brackets for manual transport can be fitted as shown on the drawing:</p>	

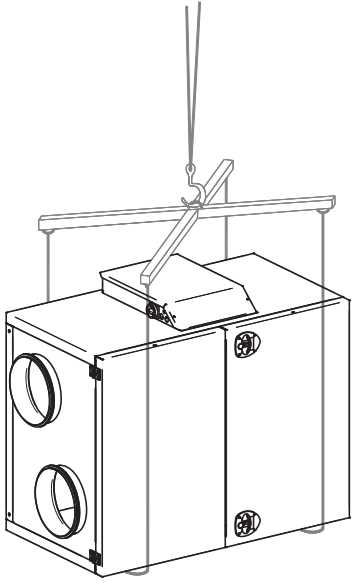
Method	Drawing
<p>Pallet truck or fork-lift truck: Lift the VEX unit on the disposable pallet. <b>IMPORTANT:</b> If the disposable pallet cannot be used, the forks on the lifting equipment must be long enough to prevent damage to the bottom of the unit.</p>	
<p>Crane:  <b>Never lift the VEX unit with the lifting brackets by using a crane.</b> Use straps and lifting yokes to prevent damage to the unit.</p>	

**2.2.1 Passage through openings**

**Height** VEX height is 1757 mm + any base spigot (+62 mm).

**Width** The list below shows how wide the opening has to be for the VEX unit to pass through:

If the opening width is*	Then
less than 900 mm	the unit will not pass through.
900–950 mm	remove doors, see relevant section.
greater than 950 mm	the unit can pass through.

\* Measurements are based on the exact dimensions of the air handling unit

## 2.2.2 Internal transport with reduced weight

### Removing the service doors

To remove the service doors:

- Open both doors.
- Using a small punch or similar tool, knock the pin out of the top of the door hinges (A), and lift the doors off.

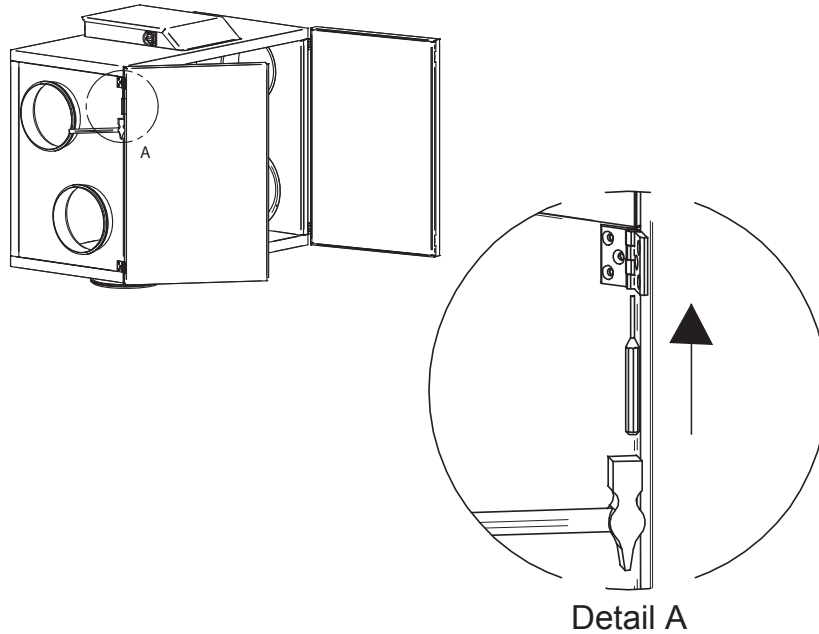

RD10247-02

### Weight reduction

The air handling unit's weight can be reduced during transport by removing service doors, fans and counterflow heat exchanger. The table below shows how much weight can be reduced by removing the various parts.

Parts	Weights, VEX160CF
Fan, 2 items at	26 kg = 52 kg
Counter flow heat exchangers, 1 item at	46 kg
Doors, 2 items at	35 kg = 70 kg
Total weight	410 kg

### To remove the fan unit

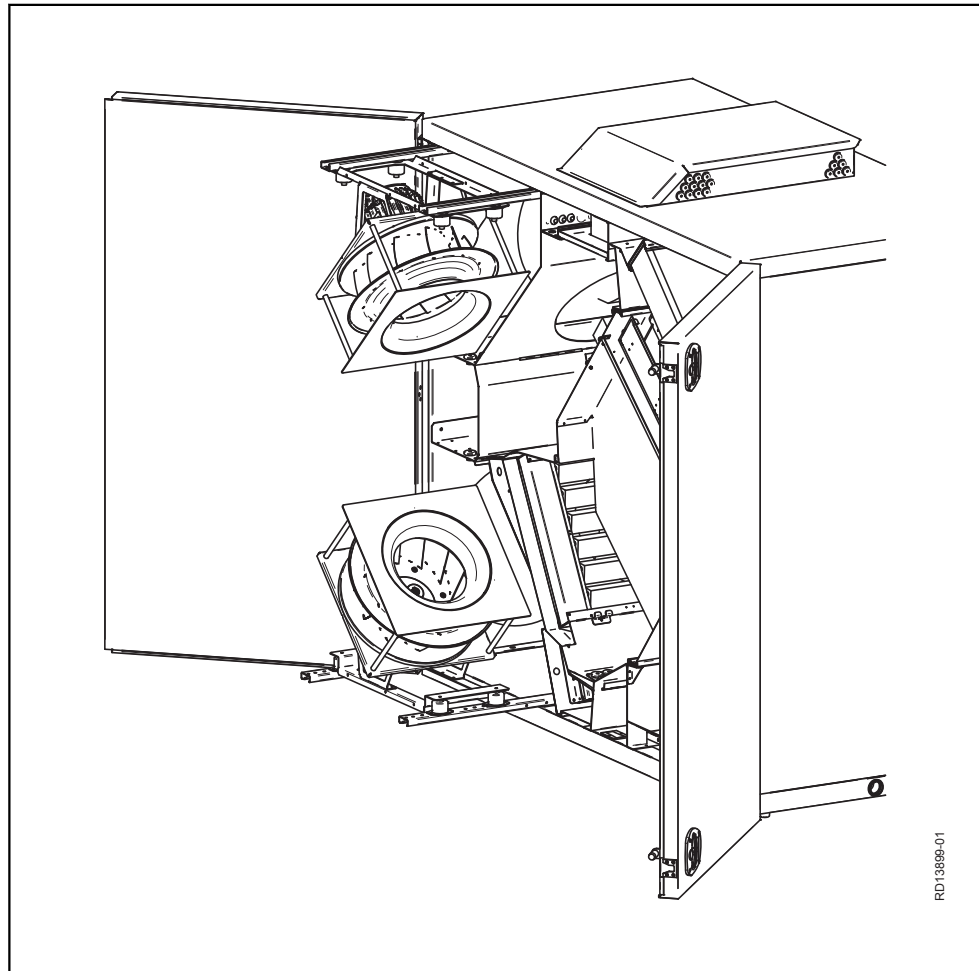

Step	Action
1	Remove the fixing screw from the sliding rail, and release the ties on the motor cable.
2	Pull the fan unit out to the stop (two screws) on the sliding rail.
3	Dismount the motor cable from the motor control on the sliding panel and pull it towards the motor through the rubber grommets.
4	Remove the two sliding rail screws. The fan unit can now be lifted off.

### Note weight



The fan units weigh 26 kg each - requiring two persons to lift each unit.

### Removal

See section "Maintenance" for instructions for dismounting fans and counterflow heat exchanger and for removal of filters.



## 3. Mechanical assembly

### 3.1 Installation

**Description** It is important that the VEX is installed on a level surface, as this affects the collection and draining of the condensate.

#### 3.1.1 Installation directly on floor

The requirements for the floor surface must be met, see the section entitled "Requirements for underlying surface".

**NB** After installation, check the VEX unit is completely level.

#### 3.1.2 Installation on mounting base

The EXHAUSTO mounting base enables the VEX unit to be installed correctly. The base is equipped with adjustable levelling screws, so that the air handling unit can be fitted horizontally on a surface that is not level ( +/- 20 mm per metre). See the separate instructions for installing the mounting base.

### 3.2 Condensation outlet



**Connection of the condensation outlet must be made by an authorised plumber.**



**Drain the condensation outlet into a floor gully or similar. The condensation outlet must be fitted with a water trap. See below.**

#### Risk of frost



**Where there is a risk of frost: It is recommended to protect the condensation outlet against frost damage. Fit a SIPHONE electrical heat tracing device on the outlet before the pipes are insulated. For fitting, see the device's fitting instructions.**

#### 3.2.1 Establishment of condensation outlet

**Location** The following two drawings show examples of how the drain from the condensation outlet can be established and the correct dimensions for the water trap:



### Solution with siphon water trap (accessory)

The siphon water trap is easy to install and service.

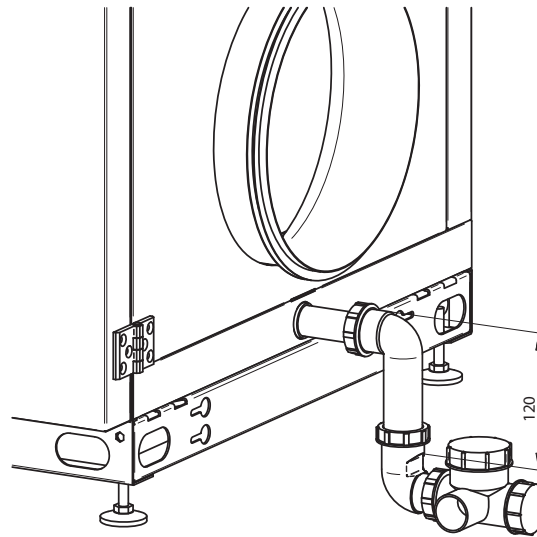

RD13442-01

### Solution with HT pipe

Use HT pipe (HT, DN32, DIN4102), if the above solution is not employed (not supplied by EXHAUSTO).

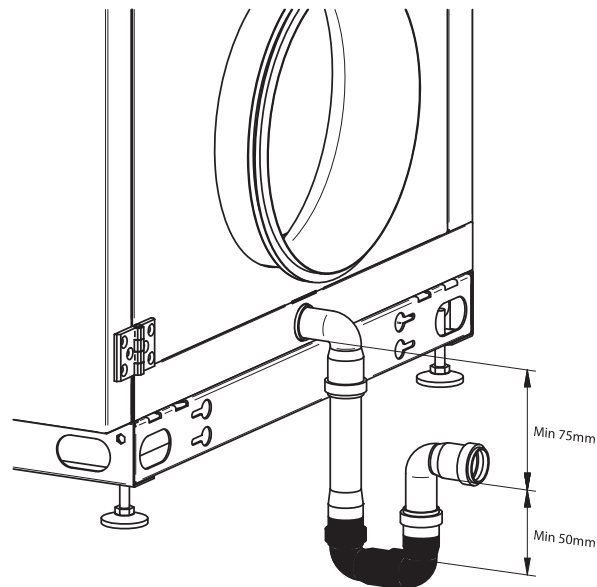

RD10185-02

### NB:

If the VEX is erected on a mounting base, this will allow sufficient free height for installing a water trap.

### 3.3 Water heating coil

#### 3.3.1 Principles for connecting the water heating coil

##### Mixing loop

The diagrams below are simplified. The dimensioning of valves, pipes, etc. and heating coil connection must always be carried out by authorised fitters in accordance with applicable regulations and legislation.

Type	Method	Simplified diagram
Mixing loop 1	Variable flow in the primary circuit (supply) and constant flow in secondary circuit (VEX unit)	
Mixing loop 2	Constant flow in the primary circuit (supply) and the secondary circuit (VEX unit)  a) When there is no heating requirement, valve adjustment must be based on the required primary circuit water flow	
	<p>Do not connect the heating coil like this!</p> <p>Connection without circulation pump risks frost damage!</p>	

RD12842-02

RD12800-03

## Explanation of simplified diagram

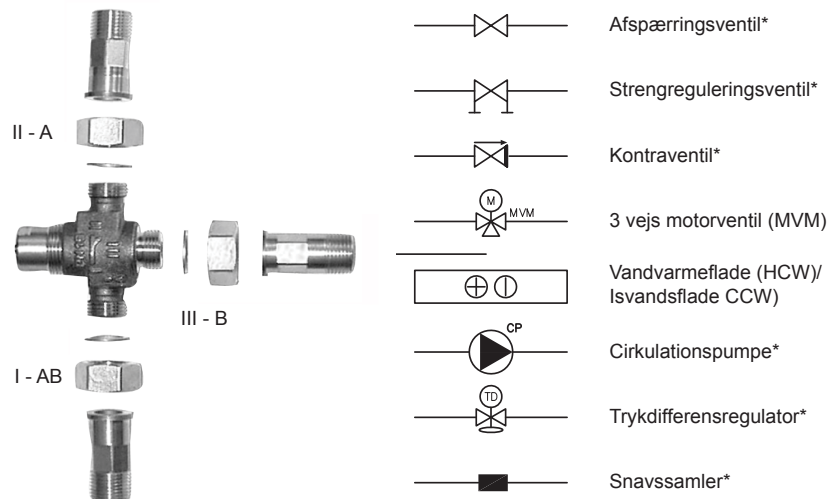

RD12642DK-02

\*) not EXHAUSTO delivery (refer to the technical specifications).

### 3.3.2 Bleeding of coils

#### Bleeding

It is the responsibility of the contractor/customer to ensure that the bleeding option is correctly installed and that the building owner is informed of the risk of insufficient bleeding, regardless of whether the coil(s) in question are built into a ventilation system or mounted separately in the duct system.

The following must be observed when bleeding liquid-coupled coils/heating and cooling batteries:

- The heating/cooling system must be arranged in accordance with DS469 so that they can be bled.
- Ventilation systems installed above suspended ceilings or outside on roofs are often the top point of the pipe system and therefore air is often collected in the system here.
- Bleeding points must be easily accessible.
- Bleeding points must be selected so that all air in the system can be bled.
- Air pots and automatic air vents should be considered so that air is collected before it enters the coils, despite the fact that many coils are equipped with a bleeding option.
- A lack of bleeding can lead to a lack of water flow and, ultimately, frost damage to the coils and subsequent water damage to the building.

Following connection of water supply to the unit:

- Bleed the system thoroughly using the upper bleed screw on the water coil.



### 3.3.3 Bleeding of coils

#### Bleeding

It is the responsibility of the contractor/customer to ensure that the bleeding option is correctly installed and that the building owner is informed of the risk of insufficient bleeding, regardless of whether the coil(s) in question are built into a ventilation system or mounted separately in the duct system.

The following must be observed when bleeding liquid-coupled coils/heating and cooling batteries:

- The heating/cooling system must be arranged in accordance with DS469 so that they can be bled.
- Ventilation systems installed above suspended ceilings or outside on roofs are often the top point of the pipe system and therefore air is often collected in the system here.
- Bleeding points must be easily accessible.
- Bleeding points must be selected so that all air in the system can be bled.
- Air pots and automatic air vents should be considered so that air is collected before it enters the coils, despite the fact that many coils are equipped with a bleeding option.
- A lack of bleeding can lead to a lack of water flow and, ultimately, frost damage to the coils and subsequent water damage to the building.

Following connection of water supply to the unit:

- Bleed the system thoroughly using the upper bleed screw on the water coil.



**Insufficient bleed-  
ing**



**Insufficient bleeding can result in still water forming in the system, which may result in frost-induced leaks during the winter.**

**Fitting motor valve**



**The valve must not be fitted with the motor facing down**

**Insulate the supply  
pipe and heating  
coil**



**The pipes and heating coil must be insulated according to applicable regulations**

### 3.3.4 MVM valve

**Definition**

MVM is used as a general term for an engine valve.

**Screening**

Screen the valve motor from direct sunlight. Due to heat emissions, the valve motor must not be encapsulated (max. ambient temperature: 50°C).

**Insulating the valve**

To ensure normal operation at ambient temperatures below 0°C, it is very important that the valve section is insulated according to current standards/procedures.

**MVM-OD, valve for  
outdoor fitting**

If MVM-OD (MVM intended for outdoor fitting) is used, the screening and insulation are part of the delivery. MVM-OD is only possible for valve sizes below 6.3 K<sub>VS</sub>.

**Regulating proper-  
ties**

Optimal regulation is achieved when the differential pressure is between 5–20 kPa. See section "Technical specifications" to calculate K<sub>VS</sub>.

**Heat supply**

The heat supply **must** be constant.

**Exercise cycle of circulation pump**

The circulation pump is exercised with the EXact2 control, as described here:

1. When no heating is required, the MVM valve operates at 0%.
2. The circulation pump then runs for a further 5 min and then stops.
3. EXact control starts the 24 hour timer.
4. When the 24 hours have passed, the circulation pump performs an exercise cycle for 5 min.
5. The exercise cycle is repeated once a day until there is no heating requirement.



## 4. Electrical installation

### 4.1 Electrical installation

See the attached instructions "Guide to Electrical Installation of VEX100 CF with water heating coil and EXact2 control system":

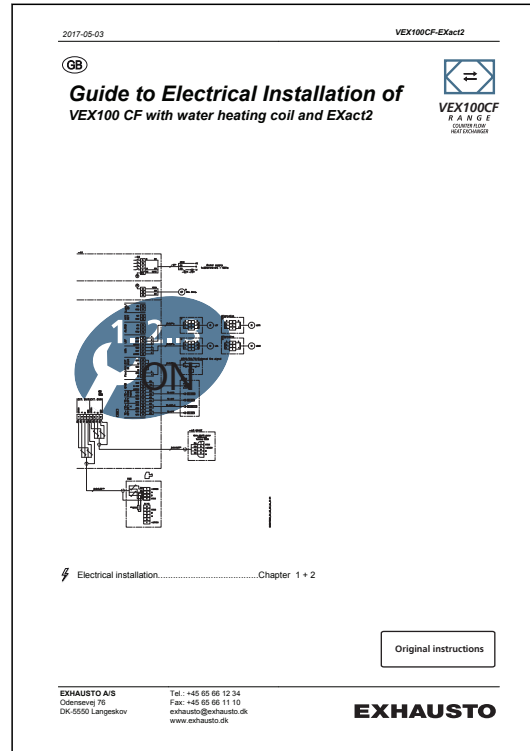



## 5. Maintenance, hygiene and servicing

### 5.1 Operating readings via the HMI panel

#### HMI panel

Refer to the "EXact2 Control System Basic Instructions for VE100/100CF" for instructions on accessing Menu 2 "Operation displays" via the technician menu (access code 1111) to check the unit's operating status.

### 5.2 Maintenance

#### 5.2.1 Overview of maintenance intervals

The following chart details the recommended maintenance intervals for the VEX. The intervals are a guide and based on normal operation. EXHAUSTO recommends maintenance is adjusted to match the actual operating requirements.

Component	Procedure	Twice a year	Once a year
Filters*	<p><b>Change filters when HMI displays filter alarm</b></p> <p>Recommended that both filters are replaced at the same time.</p> <p><b>NB:</b> The control system can issue a warning when the filter is becoming soiled.</p> <p>Filters should be replaced at least:</p>	X	
Filter monitor	Check that all the seals in the filter monitor are tight.		X
Seals and sealing strips	Check that all the seals are tight.		X
Fan	<ul style="list-style-type: none"> <li>Check that the fan impeller is securely fixed to the shaft. Removal of fan unit. See section "Internal transport with reduced weight"</li> <li>Cleaning. See section "Servicing and cleaning"</li> </ul>		X
Counterflow heat exchanger	Clean the heat exchanger. See section "Cleaning of counterflow heat exchanger"		X
Bypass damper	Check damper function		X
Heating coil	Clean the heating coil. See section "Cleaning of heating coil"		X
Safety functions check	<ul style="list-style-type: none"> <li>Fire thermostat check</li> <li>Temperature sensors on heating pipes</li> </ul>		X
Closing damper	Check damper function		X
Condensation outlet	Check that the outlet functions by pouring water in the condensation tray		X
Motor valve/circulation pump	Check function		X

#### \*Filters



#### Only use original EXHAUSTO filters

- The provided filter data (section "Technical data") are based on the use of original EXHAUSTO filters
- Eurovent certification is only valid if original filters are used.
- Use of non-original filters may cause leakage in the VEX unit, impair filter function and cause an extraordinary pressure drop.
- EXHAUSTO recommends that you register the filter replacement date to ensure filters are replaced at the correct intervals.

### 5.3 Hygiene (VEX100VDI only)

#### VDI6022 air hygiene standard

To ensure that the VEX100 meets the requirements of the VDI6022 hygiene standard, its design ensures that:

- bacterial growth and dirt accumulation are minimal
- conditions for cleaning are optimum

#### Filter ePM<sub>1</sub> 55%

The outdoor air side of the unit must as a minimum be fitted with an ePM<sub>1</sub> 55% filter (F7) to meet VDI 6022 requirements.

### 5.4 Servicing and cleaning

#### 5.4.1 Filter change



**Disconnect power at the isolation switch before opening the door.**

Pull the filters out. Remember to check the flow direction - see the arrows on the filter. Discarded filters must be stored immediately in sealed plastic bags and disposed of responsibly.

#### Filter change in menu 8.1

**After filter change (timer operation only):** Go to menu 8.1 in the EXact control system and select "Yes" next to filter change to reset the operating days counter.

#### 5.4.2 Cleaning the fans

Step	Action
1	Switch off the power supply to the unit at the isolation switch before opening the doors.
2	Pull out the fan section: Release the fixing screw on each sliding rail and undo the ties on the motor cables. Pull the fan unit out to the stop (two screws) on the sliding rails.
3	Clean the fan impeller with a vacuum cleaner and wipe down with a damp cloth if necessary. Clean the blades on the fan impeller carefully to avoid disrupting the balance. If there are weights on the fan impeller, these must not be removed.
4	After cleaning the fan impeller, check that the unit does not vibrate when operating.

#### 5.4.3 Cleaning the heating coils

Step	Action
1	Switch off the power supply to the unit at the isolation switch before opening the doors.
2	Vacuum clean the heating coil
3	Check that the fins on the heating coil are not deformed.  <div style="display: flex; align-items: center; justify-content: center;"> <p><b>The fins are sharp.</b></p> </div>

#### 5.4.4 Removing and cleaning the counterflow heat exchangers

##### Warnings



**Disconnect power at the isolation switch before opening the doors.**







Take care, as the counterflow heat exchanger is heavy - (see weight under Technical Data)



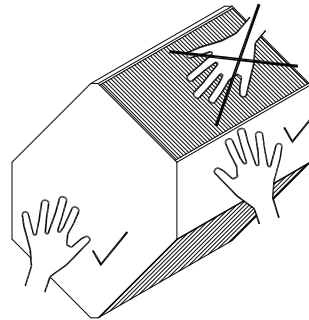

The counterflow heat exchanger fins can be easily damaged - avoid contact with the fins when handling.

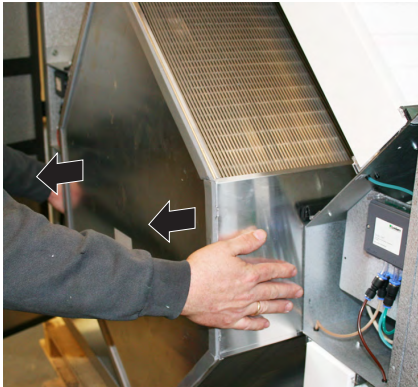

### 5.4.5 Cleaning the counterflow heat exchanger

Step	Action	
1	Remove the plug from the bypass motor.  Hold down the split pin under the plug using a screw driver as shown on photo  Then remove the plug	
2	Carefully remove the bypass (do not wrench it out)	

Step	Action
3	<p>Make sure the Tice sensor/fitting is free of the counterflow heat exchanger before extracting it.</p> 
4	<p>Remove the counterflow heat exchanger all the way.</p> <p><b>Note the weight of the heat exchanger, see technical data – min. two people when lifting.</b></p> 
5	<p>Clean the counterflow heat exchanger by flushing with hot water or by pressure hosing.</p> <p>Max. water temperature 90°C.</p>
6	<p>Replace the counterflow heat exchanger and then the bypass.</p> <p>Check that the Tice sensor is correctly positioned between the heat exchanger fins, as the sensor will not measure correctly otherwise.</p> 
7	<p>Re-insert the plug for the bypass motor.</p>



## 6. Technical data

### 6.1 Weight, corrosion class, temperature ranges, etc.

#### Weight

VEX total weight	410 kg
Doors	2 x 35 kg
Counterflow heat exchanger	46 kg
Fan unit	2 x 26 kg
VEX for internal transport (without doors, heat exchanger and fan unit)	294 kg

#### Corrosion class

Corrosion class	Corrosion class C4 in accordance with EN ISO 12944-2
-----------------	--

#### Temperature ranges

Outdoor air temperature	-40°C to +35°C
Ambient temperature	-30°C to +50°C

At temperatures below -25°C (with outdoor installation), use of a thermostatically controlled heater in the automated control box is recommended.

#### HMI panel

Enclosure class	IP20
Ambient temperature	0°C to +50°C

At temperatures below 0°C, the display may react more slowly than usual.

#### Fire thermostat

Cut-out temperature BT40/50/70 (adjustable)	40-50-70°C
Max. ambient temperature, sensor	250 °C
Ambient temperature, thermostat housing	0°C - +80°C
Sensor length	125 mm
Enclosure class	IP40

Temperature drop before reconnection possible min. 15°K

**Motor damper**

Motor damper type	LS (closing damper)	LSR (closing damper, spring return)
Type	LS500-24	LSR500-24
Designation	LSA/LSF	LSFR
Motor type	NM24-F	AF-24
Rotation time	75–150 s	open: 150 s close: 16 s
Ingress protection	IP42	IP42
Ambient temperature	-20°C to +50°C	-30°C to +50°C
Damper depth	100 mm	100 mm

A maximum of two LSFR dampers or four LSA/LSF dampers may be connected.

**6.2 Panel filters**

Data	VEX160		Device
	ePM <sub>10</sub> 50%	ePM <sub>1</sub> 55%	
Dimensions: h x w, 1 item per air direction	700 x 838		mm
Panel filter thickness	96		mm
Temperature resistant to	70		°C
Filter class according to ISO 16890	ePM <sub>10</sub> 50%	ePM <sub>1</sub> 55%	
Filter class according to EN 779	M5	F7	

**Final pressure drop**

For the final pressure drop over the filter, the lower of the following two methods is recommended.

- Final pressure drop = 3 x initial pressure drop
- Final pressure drop = initial pressure drop + 100 Pa

## 6.3 Water heating system

### Water heating coil

		HCW
<b>Weight</b>	Weight without fluid	9.5 kg
	Water content	2.4 l
<b>Dimensions</b>	Face area (h x b)	475 x 760 mm
<b>Data</b>	Test pressure	3000 kPa
	Max. operating pressure	1000 kPa
	Number of rows of pipes	qty. 2
	Number of circuits	qty. 5
	Pipe connection	DN20 (¾")
	Fin spacing	2.1 mm
	Permissible media temperature	5..0.95°C

### Recommendation

A precise calculation of the heating coil is recommended, to be carried out with calculation program EXselect, available on [www.exhausto.dk](http://www.exhausto.dk).

### 6.3.1 MVM motor valve

Valve	K <sub>Vs</sub> 1.0 - 4.0	K <sub>Vs</sub> 6.3
Test pressure	1600 kPa	1600 kPa
Max. differential pressure	100 kPa	200 kPa
Permissible media temperature	5°C - 110°C	5°C - 110°C
The valve will remain permanently open if the differential pressure	is greater than 100 kPa	is greater than 200 kPa

Motor	K <sub>Vs</sub> 1.0 - 4.0	K <sub>Vs</sub> 6.3
Permissible ambient temperature	-30°C - 50°C	-30°C - 50°C
Ingress protection, in accordance with IEC	IP40	IP40
Time taken to open/close	34 s	30 s
Power supply (50/60 Hz, AC/DC)	24 VAC ±20% 24 VDC ±20%	24 VAC ±20% 24 VDC ±20%
Regulation	0–10 VDC	0–10 VDC

## 6.4 Capacity diagram

## 6.5 EC Declaration of Conformity

The document is located in the door of the VEX unit. It is also available on the EXHAUSTO website by searching under the document or order number.

## 6.6 Ordering spare parts

### Find production number

When ordering spares, please state the relevant production part number. This will ensure that the correct parts are delivered. The production number is given on the front of the VEX guidelines and on the VEX rating plate.

### Contact:

Contact your local EXHAUSTO office service department to order a spare part. Contact information is given on the back cover of these instructions. See also the "Layout" section for an overview of the position and designation of parts in the VEX.

## 6.7 Environmental declaration

### Environmental documentation

The unit can be disassembled into individual product parts when worn out and in need of disposal.

Product parts	Material	Handling
Sheet parts	Aluzinc	Recycle after disassembly
Condensation tray	Stainless steel	Recycle after disassembly
Bypass dampers, heat exchangers and metal sections	Aluminium	Recycled
Insulation	Mineral wool	Recycle after disassembly
Door gasket	CFC and HCFC-free cellular rubber	For landfill waste or incineration
Fan motors, bypass motors	Aluminium, steel, copper and plastic	Recycle after disassembly
Control unit	Electronic components	Recycle via an authorised enterprise
Panel filters	Fibreglass and plastic	For landfill waste or incineration
The air handling unit is supplied on disposable pallets	Wood	For landfill waste or incineration

### Percentage weight

Handling	Percentage weight of materials per unit
Recycled	11% (mineral wool)
Recycled	85% (63% Aluzinc, 16% aluminium, 3.5% steel/iron, 2% stainless steel and 1% copper)
For landfill waste or incineration	2% (Wood, filter paper, cellular rubber)
Other	1.5% (electronic components)
Total	100%





Scan code and go to addresses at  
[www.exhausto.com](http://www.exhausto.com)