

GB





VEX160 Horizontal HCW

with EXact2 control



VEX100
R A N G E
CROSS FLOW
HEAT EXCHANGER



-  Product information..... Chapter 1 + 6
-  Mechanical assembly..... Chapter 2 + 3
-  Electrical installation..... Chapter 4
-  Maintenance..... Chapter 5

Original instructions



1. Product information

1.1. Designations used in these instructions	7
1.1.1. Simplified diagram.....	7
1.2. Application	8
1.3. Location requirements	8
1.3.1. Space requirements.....	8
1.3.2. Requirements for underlying surface.....	8
1.3.3. Condensation outlet.....	8
1.3.4. Requirements for duct system.....	9
1.4. Description	10
1.4.1. Construction of the VEX unit.....	10
1.4.2. Parts of the VEX unit.....	11
1.5. Principal dimensions	12



2. Handling

2.1. Unpacking	14
2.2. Transport	14
2.2.1. Passage through openings.....	15
2.2.2. Internal transport with reduced weight.....	16



3. Mechanical assembly

3.1. Installation	18
3.1.1. Installation directly on floor.....	18
3.1.2. Installation on mounting base.....	18
3.2. Condensation outlet	18
3.2.1. Establishment of condensation outlet.....	18
3.3. Water heating coil	19
3.3.1. Principles for connecting the water heating coil.....	19
3.3.2. MVM valve.....	21



4. Electrical installation

4.1. Electrical installation	23
---	-----------



5. Maintenance, hygiene and servicing

5.1. Operating readings via the HMI panel	24
5.2. Maintenance	24
5.2.1. Overview of maintenance intervals.....	24
5.3. Hygiene (VEX100VDI only)	25
5.4. Servicing and cleaning	25
5.4.1. Filter change.....	25
5.4.2. Cleaning the fans.....	25
5.4.3. Cleaning the heating coils.....	26
5.4.4. Cleaning the crossflow heat exchanger.....	26



6. Technical data

6.1. Weight, corrosion class, temperature ranges, etc	28
6.2. Panel filters	29
6.3. Water heating system	30

6.3.1. MVM motor valve	30
6.4. Capacity diagram.....	31
6.5. EC Declaration of Conformity.....	31
6.6. Ordering spare parts.....	31
6.7. Environmental declaration.....	32

Symbols, terms and warnings

Prohibition symbol



Failure to observe instructions marked with a prohibition symbol may result in serious or fatal injury.

Danger symbol



Failure to observe instructions marked with a danger symbol may result in personal injury and/or damage to the unit.

Scope

This instruction manual is for use with EXHAUSTO VEX-type air handling units. Please refer to the product instructions regarding accessories and extra equipment.

The instructions must be fully observed to ensure personal safety and to protect the equipment and ensure its correct operation. EXHAUSTO A/S accepts no liability for accidents caused by equipment not used in accordance with the manual's instructions and recommendations.

Supply air/extract air

This instruction manual uses the following terminology:

- Supply air
- Extract air
- Outdoor air
- Exhaust air

Accessories

The confirmation of order states which accessories are delivered with the VEX unit.

Definition

In the type designation R stands for Right, indicating that the supply air is to the right of the unit, as seen from the operating side. Supply air to the left is designated with L for Left

Warnings

Opening the air handling unit



Do not open the service doors until power has been disconnected at the isolation switch and the fans have stopped.

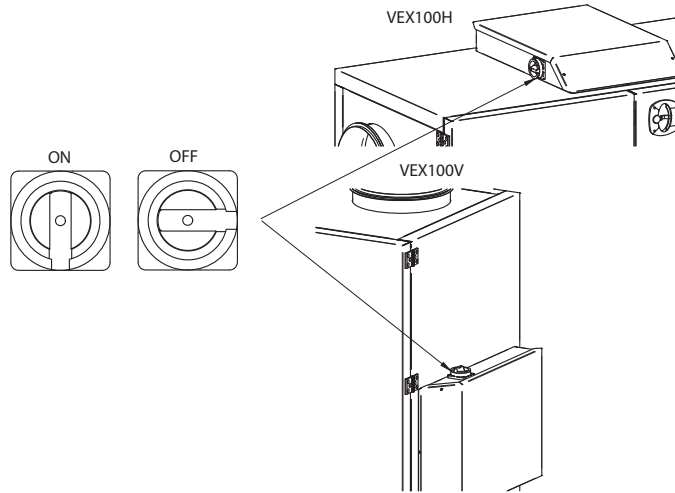

No duct connection



If one or more of the spigots is not connected to a duct: fit a protective net to the spigots with a maximum mesh size of 20 mm.

Prohibited uses



The VEX unit is not to be used to transport solid particles or in areas where there is a risk of explosive gases.

No duct connection



If one or more of the spigots is not connected to a duct: Fit a protective net to the spigots with a maximum mesh width of 20 mm (in accordance with EN294).

Lock the air handling unit during operation

The VEX unit must always be locked during operation:

- Use the cylinder lock in the handle. **Remember** to remove the key from the lock.
- Or use a padlock. Use the handle's built-in padlock fixture.

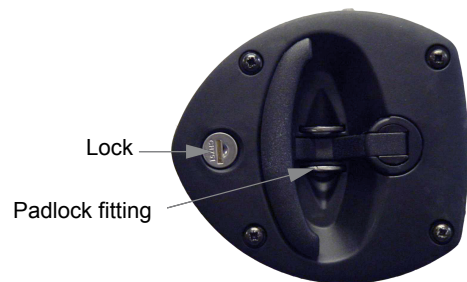

Rating plate

The VEX unit rating plate shows:

- VEX unit, type (1)
- production number (2)





EXHAUSTO A/S <small>Company Tel.: +45 4696 1400 Fax: +45 4696 1401 Email: info@exhausto.com Web: www.exhausto.com</small>			
Type	V160HLECW2	10kA	1
	No./Year 1234567/13	2	2
Supply	Voltage: 3x400V+N+PE ~50Hz	Current: 23,5A	
HEAT	HCW		

NB

Always have the production number ready when contacting EXHAUSTO A/S.

Choose the correct documentation for the task...

Find your information.

Supplied documentation	Assembly and installation instructions	Electrical installation guide	EXact2 Basic instructions	EXact2 menu guide	Print out from calculation program
Mechanical assembly » 	✓				✓
Electrical installation » 		✓			✓
Start-up - operation » 			✓	✓	✓
Maintenance - Service » 	✓	✓	✓	✓	✓



1. Product information

1.1 Designations used in these instructions

1.1.1 Simplified diagram

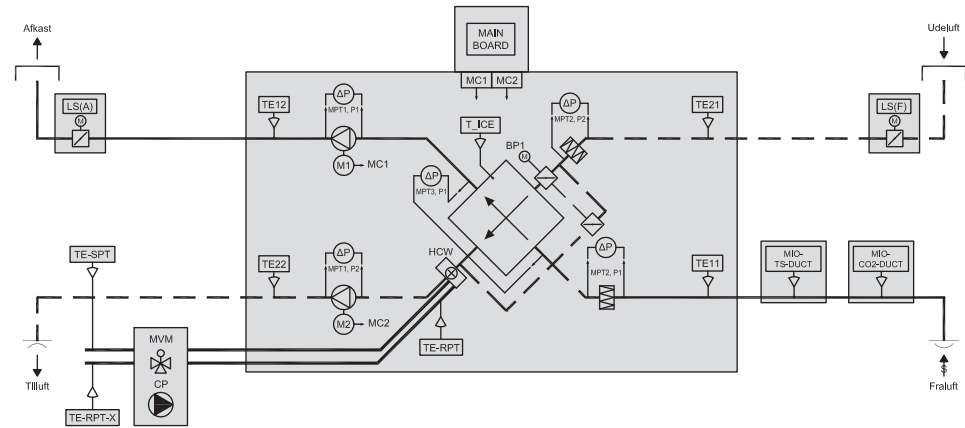

Component	Function	Standard/accessory
HCW	Water heating coil	Standard
TE-RPT	Temperature sensor in return pipe from water heating coil (internal)	Standard
MPT1, P1	Airflow control, extract air	Accessories
MPT1, P2	Airflow control, supply air	Accessories
MPT2, P1	Filter monitor, extract air	Accessories
MPT2, P2	Filter monitor, outdoor air	Accessories
MPT3, P1	Ice detection	Accessories
LS(F)/LS(F)R	Closing damper, outdoor air	Standard
LS(A)/LS(A)R	Closing damper, exhaust air	Accessories
BP1	Bypass damper	Standard
M1	Extract air motor	Standard
M2	Supply air motor	Standard
MC1	Motor controller, motor 1	Standard
MC2	Motor controller, motor 2	Standard
TE11	Temperature sensor, extract air	Standard
TE12	Temperature sensor, exhaust air	Standard
TE21	Temperature sensor, outdoor air	Standard
TE22	Temperature sensor, supply air	Standard
T _{ice}	Temperature sensor for ice in exchanger	Standard
Main Board	Connection box for MVM, CP and TE-RPT-X and TE-SPT	Standard
MVM	Motor valve	Accessories
CP	Circulation pump	Accessories
TE-SPT	Temperature sensor on feed pipe to the heating coil	Standard
TE-RPT-X	Temperature sensor on external pipeline from water heating coil	Accessories

1.2 Application

Comfort ventilation EXHAUSTO VEX is used for comfort ventilation tasks.
Operating temperature range for the unit – see section "Technical data".

Prohibited uses The VEX unit is not to be used to transport solid particles or in areas where there is a risk of explosive gases.

1.3 Location requirements

Positioning The unit is designed for indoor fitting. The unit can be ordered for outdoor fitting, in which case it is provided with a roof (accessory VEX100OD).

1.3.1 Space requirements

The drawing below indicates how much space is needed for opening the doors and servicing the unit, e.g. changing filters, cleaning, servicing, etc.

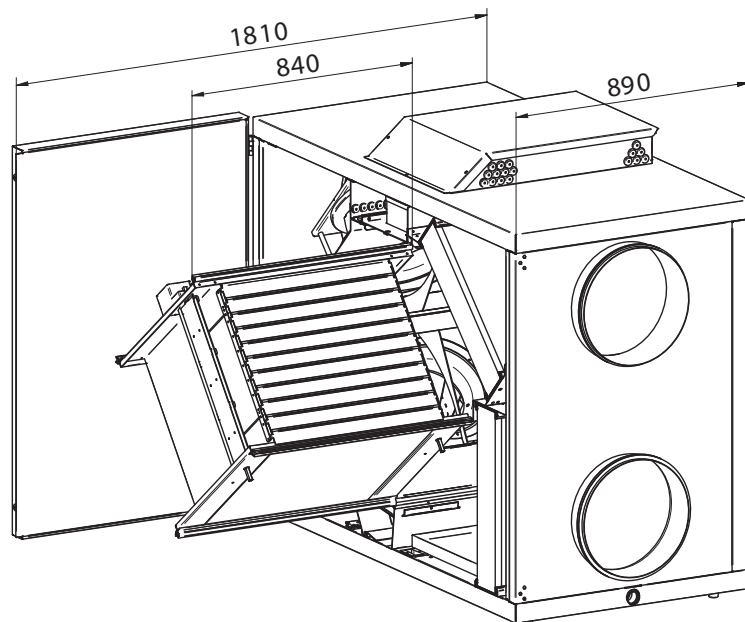

NB For servicing, the VEX must have a free height of at least 300 mm above the connection box.

1.3.2 Requirements for underlying surface

When fitting the unit directly to an existing surface - i.e. without using the mounting base (accessory) - the surface must be:

- flat
- level (+/- 3 mm per metre)
- hard
- resistant to vibration

1.3.3 Condensation outlet

A condensation outlet must be installed in the immediate vicinity of the unit. See also "Mechanical assembly" section.

1.3.4 Requirements for duct system

Silencers

The duct system must be fitted with silencers specified by the Project Manager, which meet the requirements of the operating area.

Bends

A duct bend may be fitted immediately after the unit, because the airflow in the spigot has a uniformly moderate speed profile, which results in negligible system pressure loss.

Insulation

The duct system must be insulated against:

- condensation
- sound leakage
- heating/cooling losses

Condensation

Condensation in the ducts may occur when the exhaust/outdoor air has high humidity. EXHAUSTO recommends a condensation outlet is also fitted at the lowest point in the ducts.

Outdoor air intake

The outdoor air intake must be dimensioned with sufficiently low airflow to prevent rain and snow being drawn into the duct system.

No duct connection

If one or more of the spigots is not connected to a duct: Fit a protective net to the spigots with a maximum mesh width of 20 mm.

1.4 Description

1.4.1 Construction of the VEX unit

The following drawings show an overview of the construction of left and right-hand models of VEX units (shown without doors).

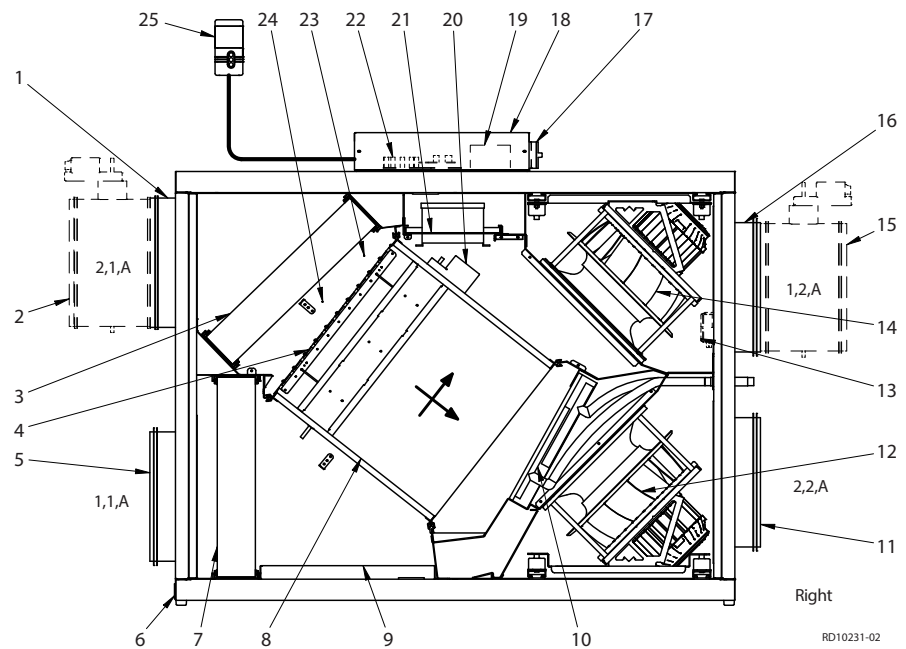
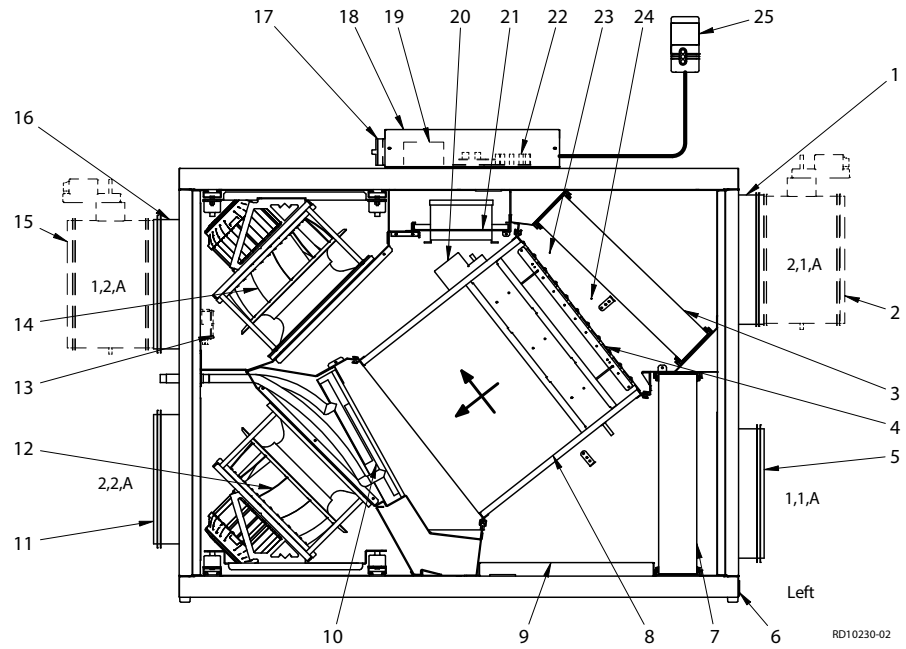

Pos.	Part	Function
1	Spigot 2,1,A	Outdoor air spigot The spigot can also be positioned on the top of the unit (2,1,B).
2	Closing damper LS	LSF, outdoor air closing damper
3	Outdoor air filter	Filters outdoor air
4	Bypass damper	For operation with heat recovery, the bypass damper is closed so that the air passes through the crossflow heat exchanger. For bypass operation, the damper is open, and the air bypasses the heat exchanger.
5	Spigot 1,1,A	Extract air spigot
6	Condensation outlet	Channels condensate to the drain.
7	Extract air filter	Filters extract air
8	Crossflow heat exchanger	Transfers heat from extract air to supply air.
9	Condensation tray	Collects the condensate and drains it away from the crossflow heat exchanger to the condensation outlet.
10	Water heating coil with bleed screw	Heats supply air if heat recovery is insufficient.
11	Spigot 2,2,A	Supply air spigot The spigot can also be positioned at the bottom of the unit (2,2,B)
12	Supply air fan	For outdoor air/supply air
13	MPT1 (AFC)	Airflow control (accessory).
14	Extract air fan	For exhaust/extract air.
15	Closing damper LS	Closing damper, exhaust air, LSA (accessory)
16	Spigot 1,2,A	Extract air spigot The spigot can also be positioned on the top of the unit (1,2,B).
17	Isolation switch	Connects/disconnects current.
18	Connection box	Connection of accessories.
19	Terminal row	Connection of accessories to ventilation unit.
20	Bypass motor	Opens/closes bypass damper.
21	Sliding plate	Positioning of motor control components.
22	EXact2 control	Control system.
23	MPT3 (DEP)	Ice detection - measurement of pressure in supply air duct (accessory)
24	MPT2 (MPTF)	Filter monitor (accessory).
25	HMI panel	Control panel.

1.4.2 Parts of the VEX unit

Cabinet The inside and outside of the cabinet are made of Aluzinc® The cabinet has been insulated with 50 mm mineral wool.

Fans The unit contains two centrifugal fans with backward curved blades for extract air and supply air.

Crossflow heat exchanger The crossflow heat exchanger in the unit is mounted with a modulating bypass damper. The crossflow heat exchanger can be removed for cleaning.

Filters The unit includes integral panel filters for both extract air and supply air.

1.5 Principal dimensions

VEX160H, Left

The following drawing gives the principal dimensions:

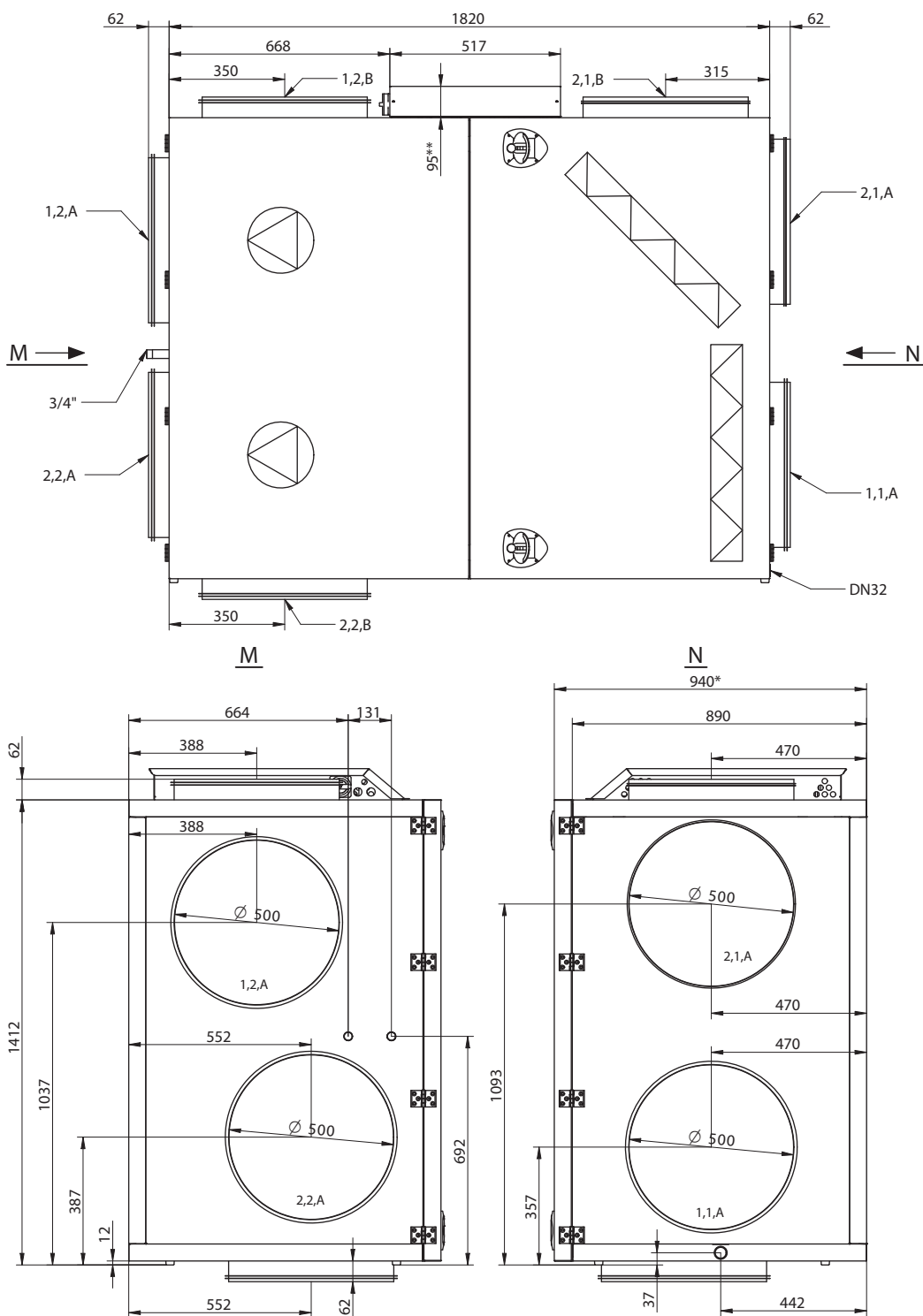

NB

The drawing shows all of the spigot positioning options.
 * Allow a distance for service in front of the unit equivalent to the unit depth.
 ** Allow a min. of 300 mm free height for service.

RD10272-02

VEX160H, Right

The following drawing gives the principal dimensions:

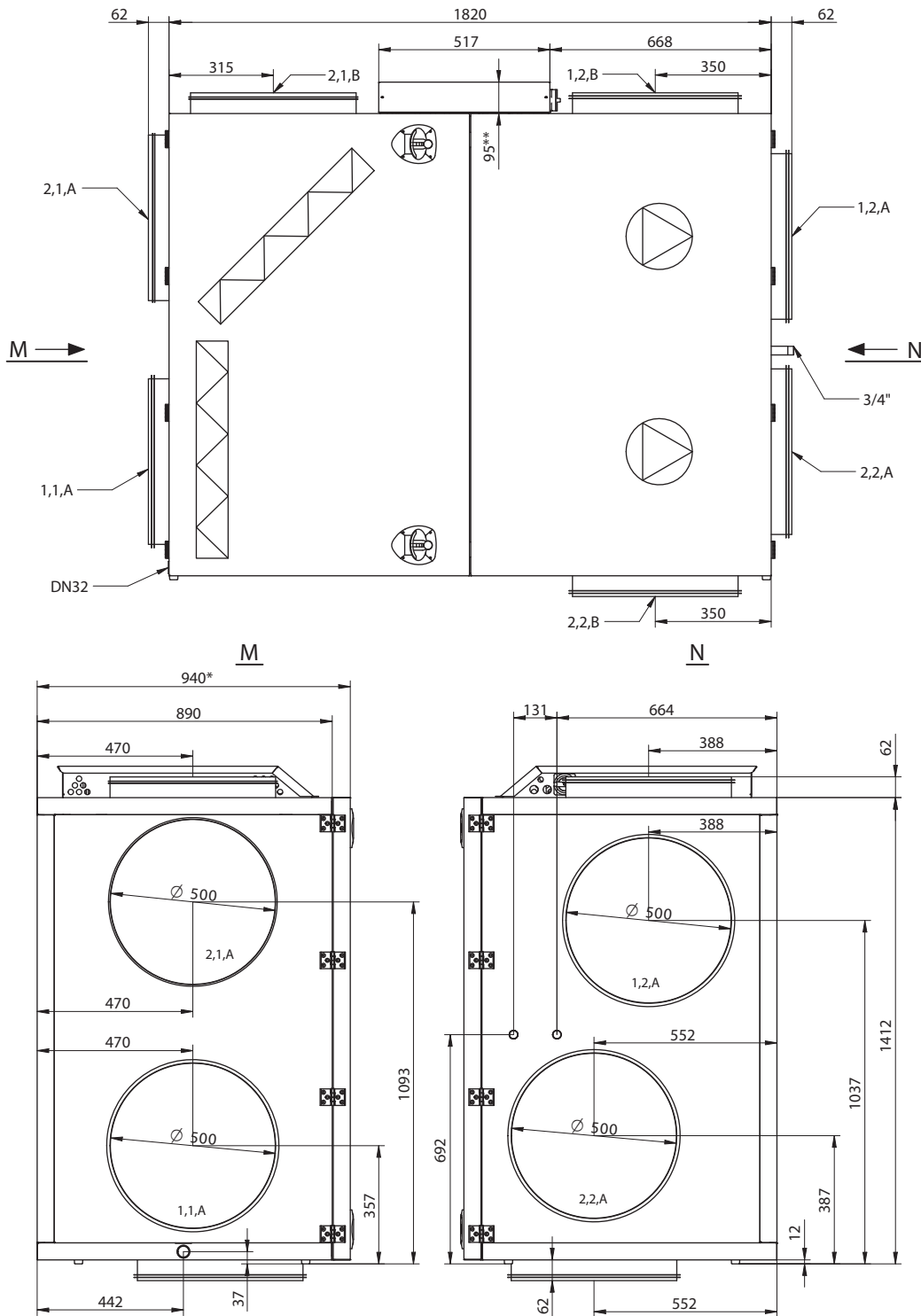

NB

The drawing shows all of the spigot positioning options.
 * Allow a distance for service in front of the unit equivalent to the unit depth.
 ** Allow a min. of 300 mm free height for service.

RD10273-02



2. Handling

2.1 Unpacking

Supplied components

The following components are supplied:

- VEX unit
- Supplied accessories (as indicated in the checklist on the front page of the instructions).

Packaging

The unit is delivered on a disposable pallet and packed in clear plastic.

NB

Once the plastic has been removed, the unit must be protected against dirt and dust:

- **The covers on the spigots must not be removed until the spigots are connected to the ventilation ducts.**
- **Whenever possible, keep the unit closed during fitting.**

The unit should be cleaned before it is used.

Once the VEX unit is fitted, it must be checked and thoroughly cleaned. All dust, debris and metal shavings must be vacuumed up.

2.2 Transport



Transport

Transport the VEX unit on the disposable pallet. Do not lift it with the spigots or connection box.

Transport methods

Transport the VEX unit in one of the following ways:

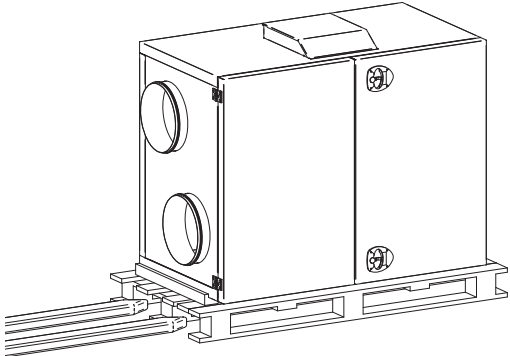
Method	Drawing
<p>Manual transport: Lifting brackets for manual transport can be fitted as shown on the drawing:</p>	

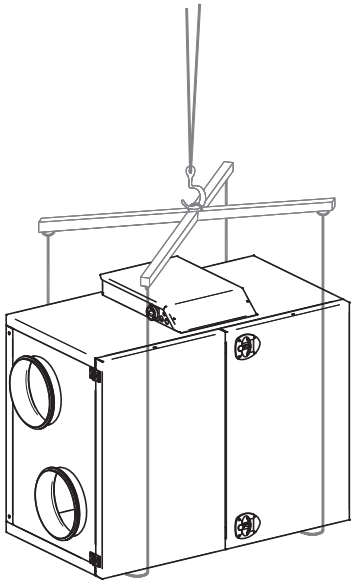
Method	Drawing
<p>Using pallet truck or fork-lift truck: Lift the VEX unit on the disposable pallet. IMPORTANT: If the disposable pallet cannot be used, the forks on the lifting equipment must be long enough to prevent damage to the bottom of the unit.</p>	
<p>Crane:  Never lift the VEX unit with the lifting brackets by using a crane. Use straps and lifting yokes to prevent damage to the unit.</p>	

2.2.1 Passage through openings

Height VEX height is 1507 mm + any base spigot (+62 mm).

Width The list (below) shows how wide the opening has to be for the unit to pass through:

If the opening width is ...*)	Response
less than 900 mm	the unit will not pass through.
between 900 and 950 mm	remove doors, see relevant section.
greater than 950 mm	the unit can pass through.

*) Measurements are based on the exact dimensions of the VEX unit.

2.2.2 Internal transport with reduced weight

Removing the service doors

To remove the service doors:

- Open both doors.
- Using a small punch or similar tool, knock the pin out of the top of the door hinges (A), and lift the doors off.

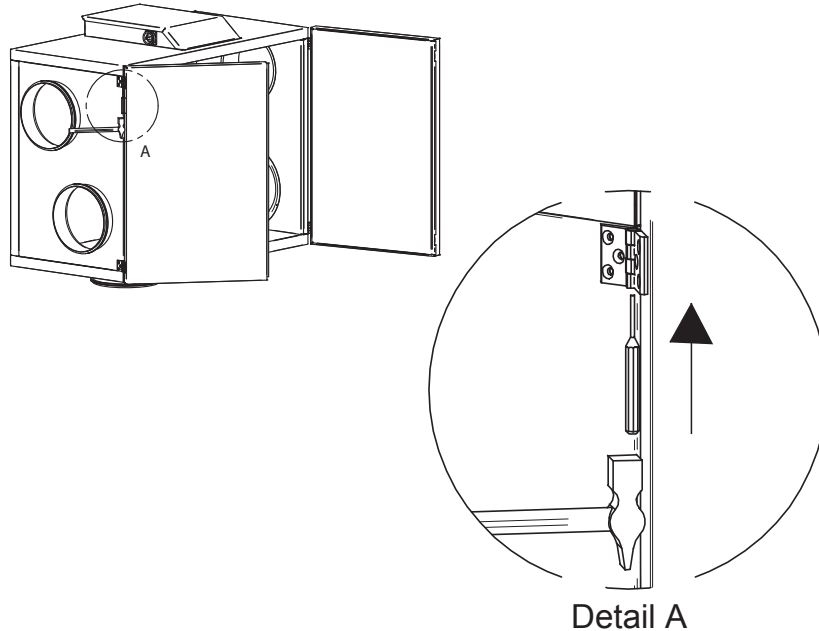

RD10247-02

Weight reduction

The weight can be reduced during transport by removing service doors, fans and crossflow heat exchanger. The table below shows the how much weight can be reduced by removing the various parts.

Parts	Weights, VEX160H
Fan, 2 items at	26 kg = 52 kg
Crossflow heat exchanger, 1 item at	51 kg
Doors, 2 items at	24 kg = 48 kg
Total weight	360 kg

To remove the fan unit

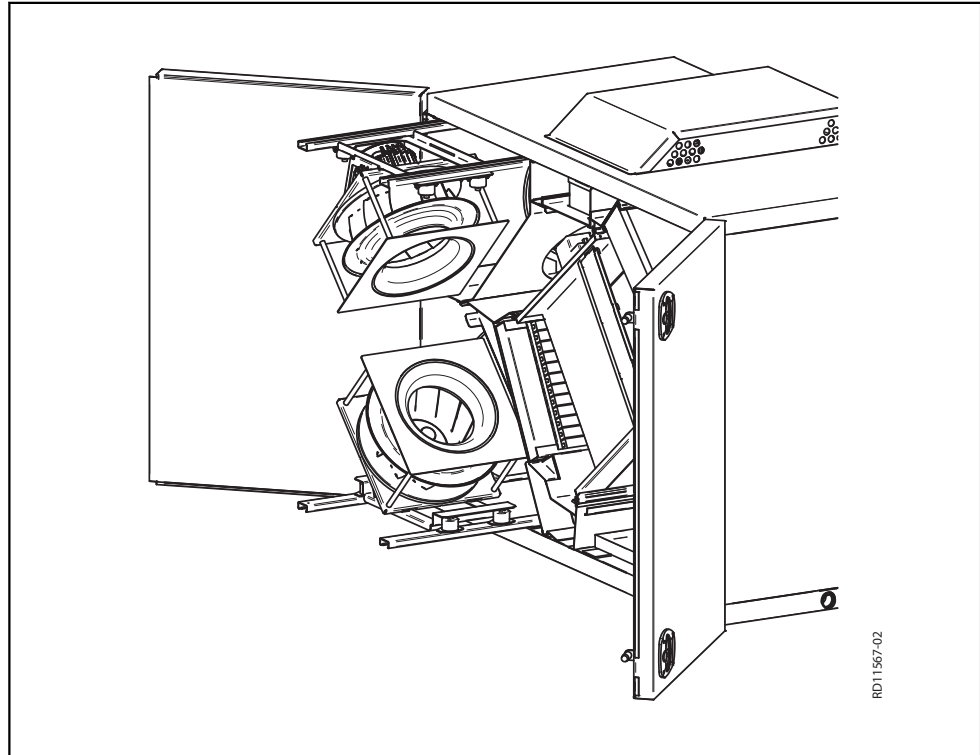

Step	Action
1	Remove the fixing screw from the sliding rail, and release the ties on the motor cable.
2	Pull the fan unit out to the stop (two screws) on the sliding rail.
3	Dismount the motor cable from the motor control on the sliding panel and pull it towards the motor through the rubber grommets.
4	Remove the two sliding rail screws. The fan unit can now be lifted off.

Note weight



The fan units weigh 26 kg each - requiring two persons to lift each unit.

Dismounting

See section "Maintenance" for instructions for dismounting fans and crossflow heat exchanger and for removal of filters.



3. Mechanical assembly

3.1 Installation

Description It is important that the VEX is installed on a level surface, as this affects the collection and draining of the condensate.

3.1.1 Installation directly on floor

The requirements for the floor surface must be met, see the section entitled "Requirements for underlying surface".

NB After installation, check the VEX unit is completely level.

3.1.2 Installation on mounting base

The EXHAUSTO mounting base enables the VEX unit to be installed correctly. The base is equipped with adjustable levelling screws, so that the air handling unit can be fitted horizontally on a surface that is not level (+/- 20 mm per metre). See the separate instructions for installing the mounting base.

3.2 Condensation outlet



Connection of the condensation outlet must be made by an authorised plumber.



Drain the condensation outlet into a floor gully or similar. The condensation outlet must be fitted with a water trap. See below.

Risk of frost



Where there is a risk of frost: It is recommended to protect the condensation outlet against frost damage. Fit a SIPHONE electrical heat tracing device on the outlet before the pipes are insulated. For fitting, see the device's fitting instructions.

3.2.1 Establishment of condensation outlet

Location The following two drawings show examples of how the drain from the condensation outlet can be established and the correct dimensions for the water trap:

Solution with siphon water trap (accessory)

The siphon water trap is easy to install and service.

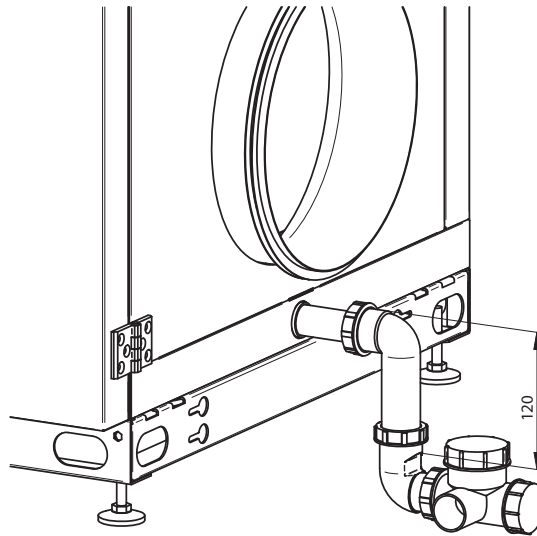

RD13442-01

Solution with HT pipe

Use HT pipe (HT, DN32, DIN4102), if the above solution is not employed (not supplied by EXHAUSTO).

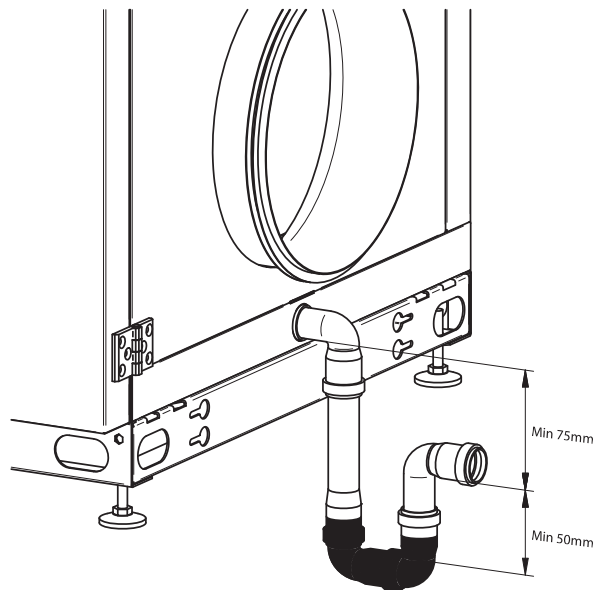

RD101852-02

NB:



If the VEX is erected on a mounting base, this will allow sufficient free height for installing a water trap.

3.3 Water heating coil

3.3.1 Principles for connecting the water heating coil

Mixing loop

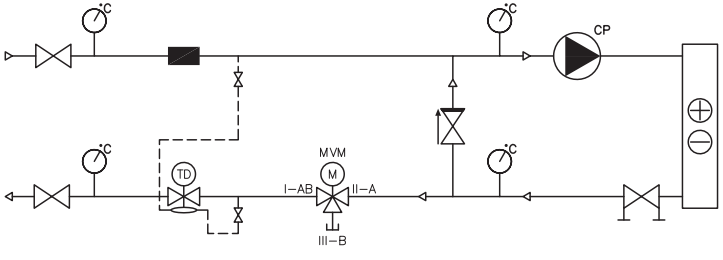
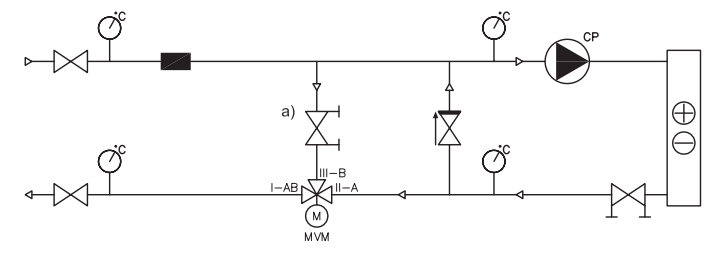
The diagrams below are simplified. The dimensioning of valves, pipes, etc. and heating coil connection must always be carried out by authorised fitters in accordance with applicable regulations and legislation.

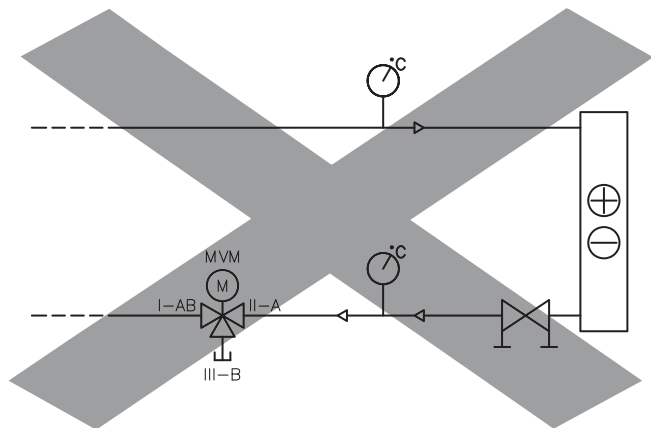
Type	Principle	Simplified diagram
<p>Mixing loop 1</p>	<p>Variable flow in the primary circuit (supply) and constant flow in secondary circuit (VEX unit)</p>	
<p>Mixing loop 2</p>	<p>Variable flow in the primary circuit (supply) and constant flow in secondary circuit (VEX unit)</p> <p>a) When there is no heating requirement, valve adjustment must be based on the required primary circuit water flow</p>	
	<p>Do not connect the heating coil like this!</p> <p>Connection without circulation pump risks frost damage!</p>	

RD12542-02

RD12500-03

Explanation of simplified diagram

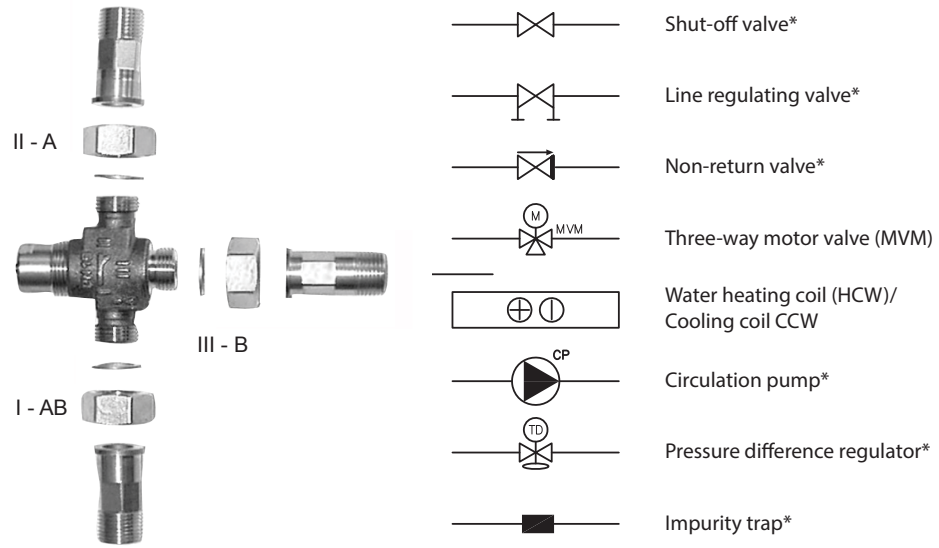

RD12642GE-02

*) not EXHAUSTO delivery (refer to the technical specifications in section 7).

Bleeding

Following connection of water supply to the unit:

- Bleed the system thoroughly using the upper bleed screw on the water heating coil

Insufficient bleeding



Insufficient bleeding can result in still water forming in the system, which may result in frost-induced leaks during the winter.

Fitting motor valve



The valve must not be fitted with the motor facing down

Insulate the supply pipe and heating coil



The pipes and post-heating coil must be insulated according to applicable regulations

3.3.2 MVM valve

Screening

Screen the valve motor from direct sunlight. Due to heat emissions, the valve motor must not be encapsulated (max. ambient temperature: 50°C).

Insulating the valve

To ensure normal operation at ambient temperatures below 0°C, it is very important that the valve section is insulated according to current standards/procedures.

MVM-OD, valve for outdoor fitting

If MVM-OD (MVM intended for outdoor fitting) is used, the screening and insulation are part of the delivery. MVM-OD is only possible for valve sizes below 6.3 K_{VS}.

Regulating properties

Optimal regulation is achieved when the differential pressure is between 5–20 kPa. See section "Technical specifications" to calculate K_{VS}.

Heat supply

The heat supply **must** be constant.

Exercise cycle of circulation pump

The circulation pump is exercised with the EXact2 control, as described here:

1. With no heat requirement, the MVM valve runs at 0%.
2. The circulation pump will then run for a further 5 min and stop.
3. EXact control will start a 24 hour timer.
4. When the 25 hours are over, the circulation pump will exercise for 5 min.
5. The exercise cycle will repeat once a day until the next time a heat requirement arises.



4. Electrical installation

4.1 Electrical installation

See the attached instructions "Guide to Electrical Installation of VEX150H/150V-VEX160H/160V-VEX170H with EXact2 control system":

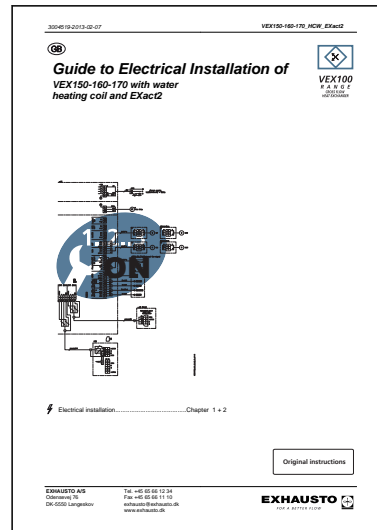



5. Maintenance, hygiene and servicing

5.1 Operating readings via the HMI panel

HMI panel

Refer to the "EXact2 Control System Basic Instructions for VE100/100CF" for instructions on accessing Menu 2 "Operation displays" via the technician menu (access code 1111) to check the unit's operating status.

5.2 Maintenance

5.2.1 Overview of maintenance intervals

The following chart details the recommended maintenance intervals for the VEX, based on normal operation. EXHAUSTO recommends maintenance is adjusted to suit the actual operating requirements.

Component	Procedure	Twice a year	Once a year
Filters*	Change filters when HMI displays filter alarm. We recommend that both filters are changed at the same time. NB: The control system can issue a warning when the filter is becoming soiled. Filters should be changed at least:	X	
Filter guide	Check that all the seals are tight		X
Seals and sealing strips	Check that all the seals are tight		X
Fan	<ul style="list-style-type: none"> Check that the fan impeller is securely fixed to the shaft. Removal of fan unit. See section "Internal transport with reduced weight" Cleaning, see section "Servicing and cleaning" 		X
Crossflow heat exchanger	Clean the heat exchanger, see section "Cleaning of heat exchanger"		X
Bypass damper	Check damper function		X
Heating coil	Clean the heating coil, see section "Cleaning of heating coil"		X
Safety functions check	<ul style="list-style-type: none"> Fire thermostat check Temperature sensors on heating pipes 		X
Closing damper	Check damper function		X
Condensation outlet	Check that the outlet works by pouring water in the condensation tray		X
Motor valve/circulation pump	Check function		X

*Filters



Only use original EXHAUSTO filters

- The provided filter data (section "Technical data") are based on the use of original EXHAUSTO filters
- Eurovent certification is only valid if original filters are used.
- Use of non-original filters may cause leakage in the VEX unit, impair filter function and cause an extraordinary pressure drop.
- EXHAUSTO recommends that you register the filter replacement date to ensure filters are replaced at the correct intervals.

5.3 Hygiene (VEX100VDI only)

VDI6022 air hygiene standard

To ensure that the VEX100 meets the requirements of the VDI6022 hygiene standard, its design ensures that:

- bacterial growth and dirt accumulation are minimal
- conditions for cleaning are optimum

Filter ePM₁ 55%

The outdoor air side of the unit must as a minimum be fitted with an ePM₁ 55% filter (F7) to meet VDI 6022 requirements.

5.4 Servicing and cleaning

5.4.1 Filter change



Disconnect power at the isolation switch before opening the door.

Pull the filters out. Remember to check the flow direction - see the arrows on the filter.

Discarded filters must be stored immediately in sealed plastic bags and disposed of responsibly.

Filter change in menu 8.1

After filter change (timer operation only): Go to menu 8.1 in the EXact control system and select "Yes" next to filter change to reset the operating days counter.

5.4.2 Cleaning the fans



Step	Action
1	Switch off the power supply to the unit at the isolation switch before opening the doors.
2	Pull out the fan section: Release the fixing screw on each sliding rail and undo the ties on the motor cables. Pull the fan unit out to the stop (two screws) on the sliding rails.
3	Clean the fan impeller with a vacuum cleaner and wipe down with a damp cloth if necessary. Clean the blades on the fan impeller carefully to avoid disrupting the balance. If there are weights on the fan impeller, these must not be removed.
4	After cleaning the fan impeller, check that the unit does not vibrate when operating.

5.4.3 Cleaning the heating coils

Step	Action
1	Switch off the power supply to the unit at the isolation switch before opening the doors.
2	Vacuum clean the heating coil
3	Check that the fins on the heating coil are not deformed. <div style="text-align: center;">  The fins are sharp. </div>

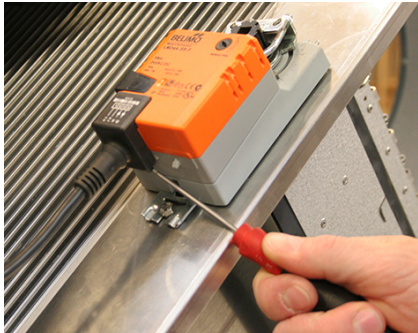
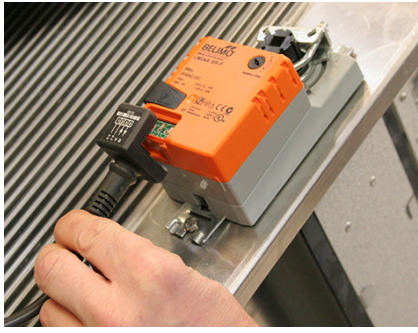
5.4.4 Cleaning the crossflow heat exchanger

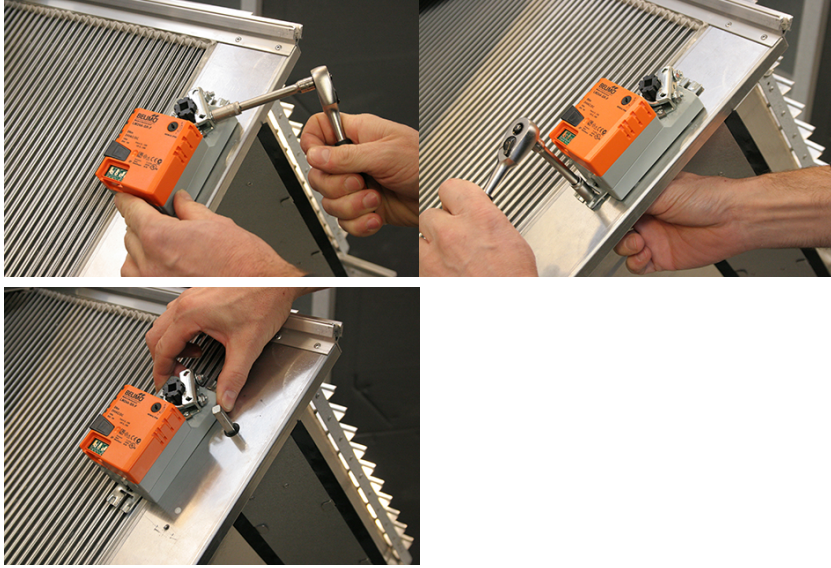
Step 1-11	Action
1	Switch off the power supply to the unit at the isolation switch before opening the doors.
2	Pull the heat exchanger out of the VEX slightly and remove the plug from the bypass motor. Hold down the split pin under the plug with a screw driver, see photos: <div style="display: flex; justify-content: space-around;">   </div>
3	Dismount the Tice sensor from the heat exchanger bracket (see photo step 10).
4	Remove the crossflow heat exchanger. Note the weight of the heat exchanger, see technical data – min. two persons for lifting.
5	Press the release button on the bypass motor and turn the damper with the louvres in open position.

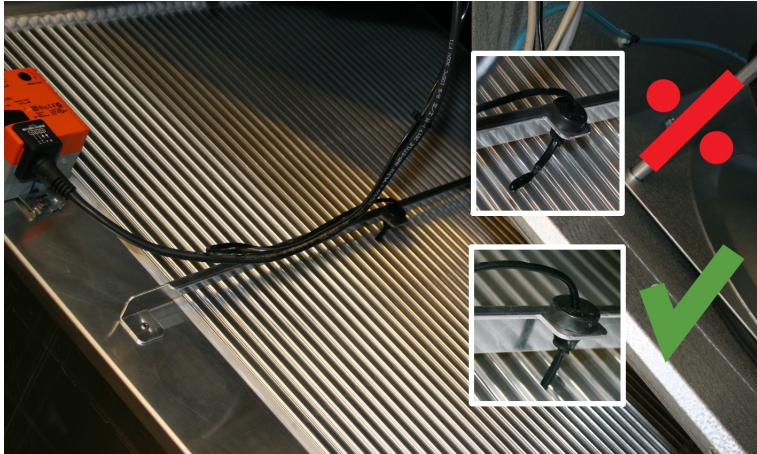
Step 1-11	Action
6	<p>The bypass motor must be dismantled before cleaning the heat exchanger with water, see photos:</p>  <p> Do not activate the release button on the bypass motor while it is dismantled, as this will alter the position of the motor compared to the damper.</p>
7	Clean the heat exchanger by flushing with hot water or by pressure washing. Max. water temperature. 90°C.
8	Mount the bypass motor. The damper must be in open position (louvres fully open), as for dismantling.
9	Shut the louvres, and replace the heat exchanger.
10	<p>Mount the Tice sensor. It is important to check that the Tice sensor is correctly positioned between the heat exchanger fins, as the sensor will not measure correctly otherwise.</p> 
11	Re-insert the plug for the bypass motor.



6. Technical data

6.1 Weight, corrosion class, temperature ranges, etc.

Weight

VEX total weight	360 kg
Doors	2 x 24 kg
Crossflow heat exchanger	51 kg
Fan unit	2 x 26 kg
VEX for transporting into building (without doors, heat exchanger and fan unit)	209 kg

Corrosion class

Corrosion class	Corrosion class C4 in accordance with EN ISO 12944-2
-----------------	--

Temperature ranges

Outdoor air temperature	-40°C to +35°C
Ambient temperature	-30°C to +50°C

At temperatures below -25°C (with outdoor installation), use of a thermostatically controlled heater in the automated control box is recommended.

HMI-panel

Ingress protection	IP20
Ambient temperature	0°C - +50°C

At temperatures below 0°C the display may react more slowly than usual.

Fire thermostats

Cut-out temperature, BT70	70°C
Cut-out temperature, BT50	50°C
Cut-out temperature, BT40	40°C
Max. ambient temperature, sensor	250°C
Ambient temperature, thermostat housing	0°C - +80°C
Sensor length	125 mm
Ingress protection	IP40

Temperature drop before reconnection possible min. 15°K

Motor damper

Motor damper type	LS (closing damper)	LSR (closing damper, spring return)
Type	LS500-24	LSR500-24
Designation	LSA/LSF	LSFR
Motor type	NM24-F	AF-24
Rotation time	75–150 s	open: 150 s close: 16 s
Ingress protection	IP42	IP42
Ambient temperature	-20°C to +50°C	-30°C to +50°C
Damper depth	100 mm	100 mm

A maximum of two LSFR dampers or four LSA/LSF dampers may be connected.

6.2 Panel filters

Data	VEX160		Device
	ePM ₁₀ 50%	ePM ₁ 55%	
Dimensions: h x w, 1 item per air direction	700 x 838		mm
Panel filter thickness	96		mm
Temperature resistant to	70		°C
Filter class according to ISO 16890	ePM ₁₀ 50%	ePM ₁ 55%	
Filter class according to EN 779	M5	F7	

Final pressure drop

For the final pressure drop over the filter, the lower of the following two methods is recommended.

- Final pressure drop = 3 x initial pressure drop
- Final pressure drop = initial pressure drop + 100 Pa

6.3 Water heating system

Water heating coil

		HCW
Weight	Weight without fluid	9.5 kg
	Water content	2.4 l
Dimensions	Face area (h x b)	475 x 760 mm
Data	Test pressure	3000 kPa
	Max. operating pressure	1000 kPa
	Number of rows of pipes	qty. 2
	Number of circuits	qty. 5
	Pipe connection	DN20 (¾")
	Fin spacing	2.1 mm
	Permissible media temperature	5..0.95°C

Recommendation



A precise calculation of the heating coil is recommended, to be carried out with calculation program EXselect, available on www.exhausto.dk.

6.3.1 MVM motor valve

Valve	K _{Vs} 1.0 - 4.0	K _{Vs} 6.3
Test pressure	1600 kPa	1600 kPa
Max. differential pressure	100 kPa	200 kPa
Permissible media temperature	5°C - 110°C	5°C - 110°C
The valve will remain permanently open if the differential pressure	is greater than 100 kPa	is greater than 200 kPa

Motor	K _{Vs} 1.0 - 4.0	K _{Vs} 6.3
Permissible ambient temperature	-30°C - 50°C	-30°C - 50°C
Ingress protection, in accordance with IEC	IP40	IP40
Time taken to open/close	34 s	30 s
Power supply (50/60 Hz, AC/DC)	24 VAC ±20% 24 VDC ±20%	24 VAC ±20% 24 VDC ±20%
Regulation	0–10 VDC	0–10 VDC

6.4 Capacity diagram

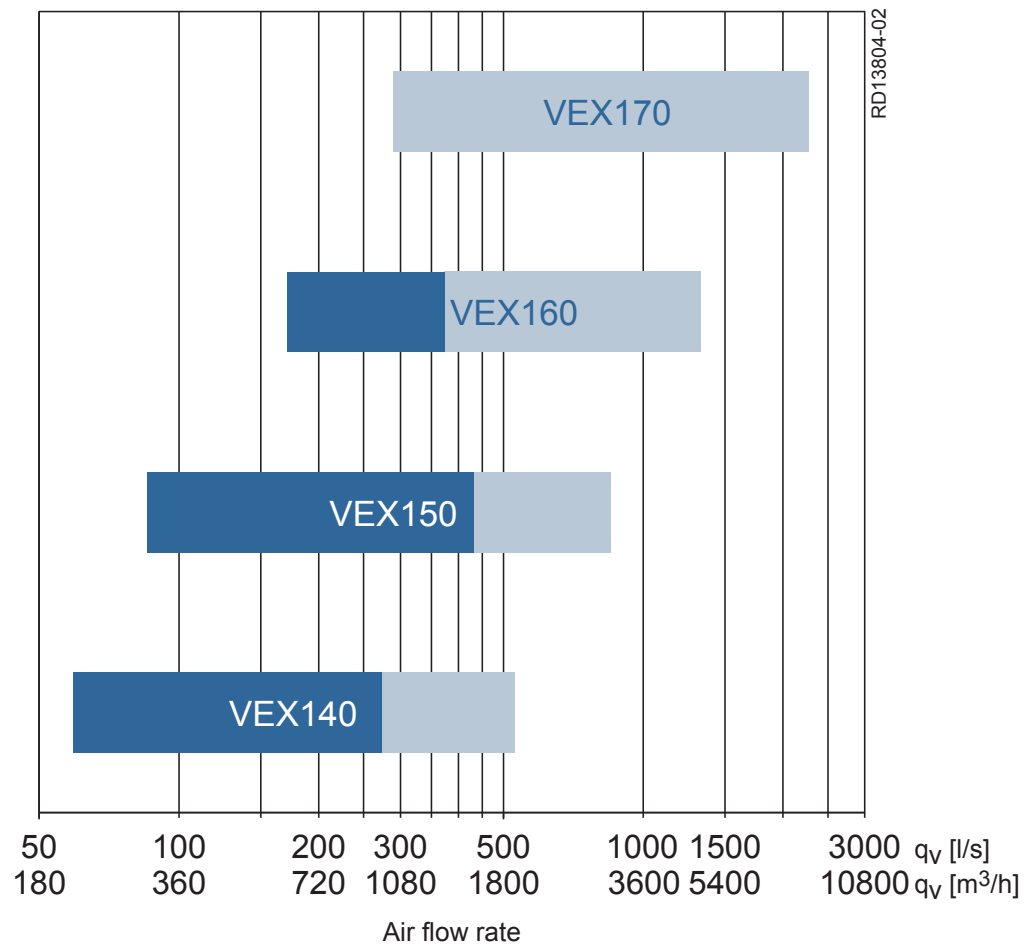

Recommendation



You are recommended to make a more precise calculation of the unit's capacity with the EXselect calculation program, available on the EXHAUSTO website.

6.5 EC Declaration of Conformity

The document is located in the door of the VEX unit. It is also available on the EXHAUSTO website by searching under the document or order number.

6.6 Ordering spare parts

Find production number

When ordering spares, please state the relevant production part number. This will ensure that the correct parts are delivered. The production number is given on the front of the VEX guidelines and on the VEX rating plate.

Contact: Contact your local EXHAUSTO office service department to order a spare part. Contact information is given on the back cover of these instructions. See also the "Layout" section for an overview of the position and designation of parts in the VEX.

6.7 Environmental declaration

Environmental documentation The unit can be disassembled into individual product parts when outworn and in need of disposal.

Product parts	Material	Handling
Sheet parts	Aluzinc	For recycling after disassembly
Condensation tray	Stainless steel	For recycling after disassembly
Bypass dampers, heat exchangers and metal sections	Aluminium	For recycling
Insulation	Mineral wool	For recycling after disassembly
Door gasket	CFC and HCFC-free cellular rubber	Dumping or incineration
Fan motors, bypass motors	Aluminium, steel, copper and plastic	For recycling after disassembly
Control unit	Electronic components	For recycling by an authorised enterprise
Cassette filter	Fibreglass and plastic	Dumping or incineration
Unit is supplied on disposable pallets	Wood	Dumping or incineration

Percentage weight

Handling	Percentage weight of materials per unit
For recycling	11% (mineral wool)
For recycling	85% (63% Aluzinc, 16% aluminium, 3.5% steel/iron, 2% stainless steel and 1% copper)
Dumping or incineration	2% (Wood, filter paper, cellular rubber)
Other	1.5% (electronic components)
Total	100%



Scan code and go to addresses at
www.exhausto.com