



Electrical installation guide

VEX170HX with third-party control system



VEX100
R A N G E
CROSS FLOW
HEAT EXCHANGER

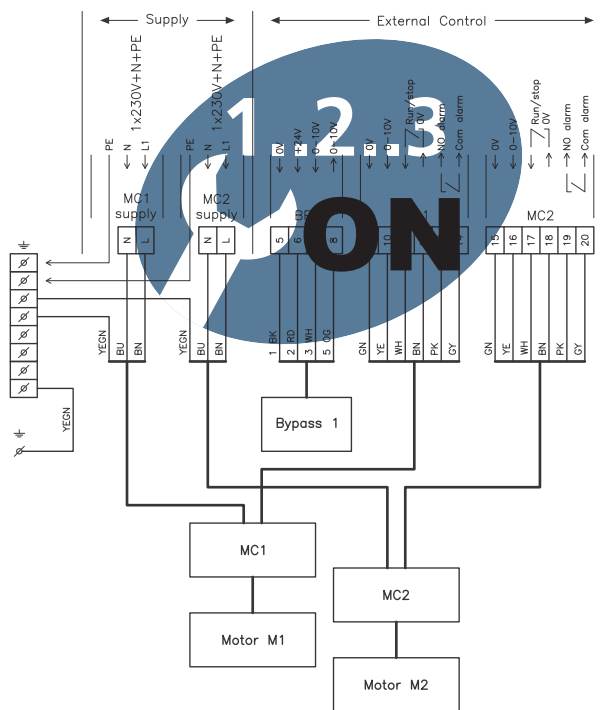

⚡ Electrical installation.....Chapter 1 + 2

Original instructions



1. Connection of voltage supply

1.1. Connection diagram for VEX with motor control (MC).....4

1.1.1. Alarm relay function.....6



2. Installation of the VEX

2.1. Scope of installation.....7

Symbols, terms and warnings

Prohibition symbol



Failure to observe instructions marked with a prohibition symbol may result in serious or fatal injury.

Danger symbol



Failure to observe instructions marked with a danger symbol may result in personal injury and/or damage to the unit.

Isolation switch



In accordance with The Machinery Directive*, an isolation switch must be permanently installed in the unit.

The isolation switch must:

- be lockable or positioned in plain sight in the immediate vicinity of the unit
- disconnect all poles from the supply voltage
- be constructed in accordance with EN 60204-1

The isolation switch is **not** supplied by EXHAUSTO.

Warnings



The work must be performed by an authorised electrician, in accordance with locally applicable regulations and legislation.

Lock the air handling unit during operation

The VEX unit must always be locked during operation:

- Use the cylinder lock in the handle. **Remember** to remove the key from the lock.
- Or use a padlock. Use the handle's built-in padlock fixture

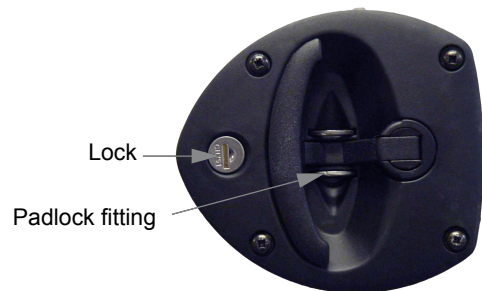

Rating plate

The VEX unit rating plate shows:

- VEX unit, type (1)
- production number (2)

Type	V160HLECW2		
	No./Year 1234567/13		
Supply	Voltage: 3x400V+N+PE ~50Hz	Current:	23,5A
HEAT	HCW		

NB

Always have the production number ready when contacting EXHAUSTO A/S.



1. Connection of voltage supply

1.1 Connection diagram for VEX with motor control (MC)

Diagram, 3 x 400 V

The diagram below illustrates connection of the supply voltage to the motor control and bypass damper.

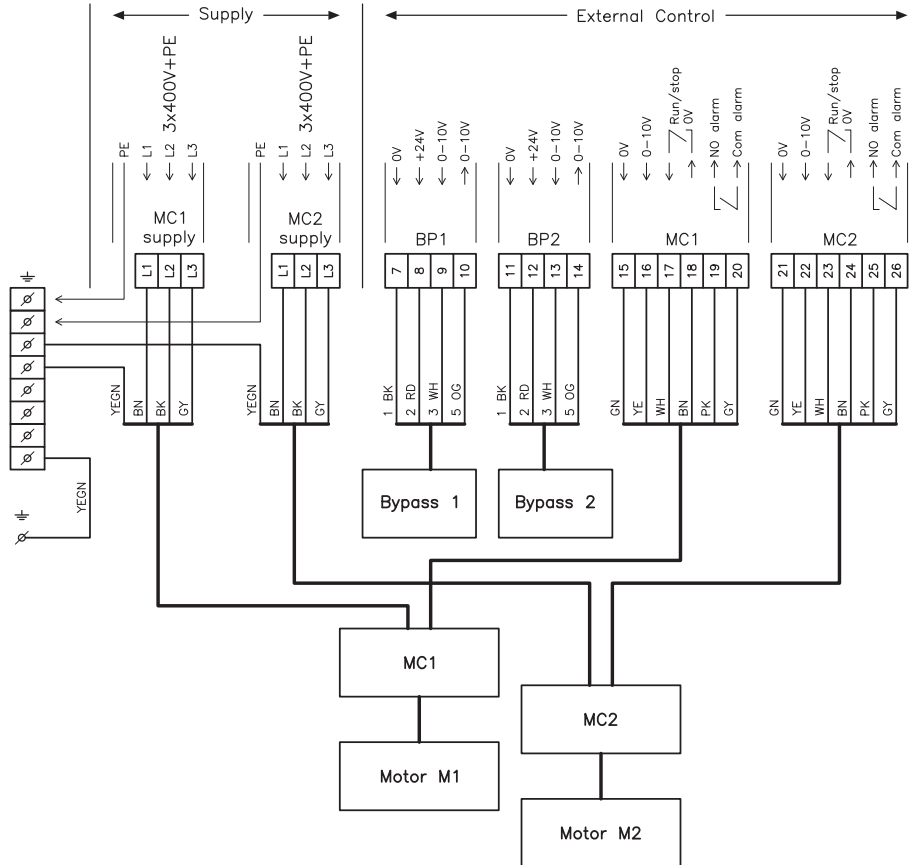

Key to diagram

Designation	Description
MC1	Control signal for motor control M1 (exhaust air/extract air)
MC2	Control signal for motor control M2 (supply air/outdoor air)
BP1	Control signal for bypass damper 1 (supply air/outdoor air)
BP2	Control signal for bypass damper 2 (supply air/outdoor air)
MC1 Supply	Power supply for motor control MC1 (exhaust air/extract air)
MC2 Supply	Power supply for motor control MC2 (supply air/outdoor air)

NB

Other parts, shown on the front page of the VEX instructions, are supplied by EX-HAUSTO

RD13489-01

Electrical data

The following table shows the max. phase current.

Type	Supply voltage	Max. Phase current (total)	MC1 phase cur- rent	MC2 phase cur- rent
VEX170	3 x 400 V + N+ PE	19 A	9.5 A	9.5 A

NB

Power consumption is taken from three phases and is not sinusoidal.

1.1.1 Alarm relay function

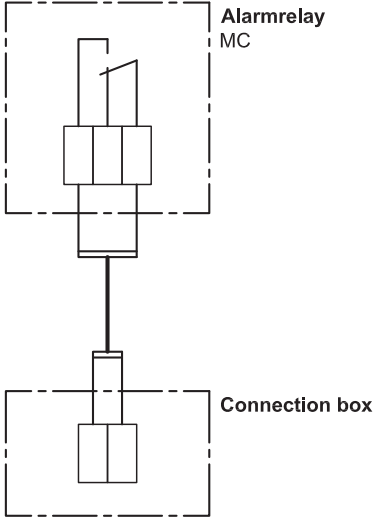
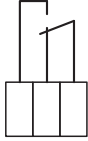
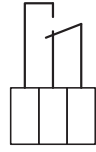
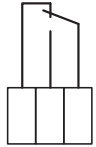
Description		Drawing
Connection	The diagram shows which two terminals from MC are connected to the terminal block in the connection box	 <p style="text-align: right;">Alarmrelay MC</p> <p style="text-align: right;">Connection box</p> <p style="text-align: right; font-size: small;">5450255GB-01</p> <p>MC: terminal 19-20 and terminal 25-26</p>
Function	The alarm relay position in the case of power failure or similar	 <p style="text-align: right;">Power off</p>
	The alarm relay position in case of alarm	 <p style="text-align: right;">Alarm</p>
	The alarm relay position during operation	 <p style="text-align: right;">Power on, No alarm</p>



2. Installation of the VEX

2.1 Scope of installation

VEX unit The electrical installation for the VEX unit comprises the following tasks:

Connection box Wiring configurations for the terminal board in the connection box:

- Supply voltage to motors and motor control (MC)
- Control signals for motor control (MC) and alarm relay
- Control signal to bypass damper

NB

- The motor control is pre-programmed by EXHAUSTO and has overload protection
- The motor control must have short-circuit protection

For other technical data, see the "Technical data" section in the main instructions of the VEX.

Bypass damper function When connecting bypass damper to the control signal, the following must be taken into consideration:

Control voltage to BP1 and BP2	Function
2 V	100% heat recovery. Outdoor air is led through the crossflow heat exchanger.
6.5 V	0% heat recovery. The outdoor air bypasses the crossflow heat exchanger.

NB BP1 and BP2 must be provided with the same control voltage so they can run synchronously.



Scan code and go to addresses at
www.exhausto.com