





GB

VEX170 for third party control system with water heating coil HCW



VEX100
R A N G E
CROSS FLOW
HEAT EXCHANGER



-  Product information..... Chapter 1 + 6
-  Mechanical assembly..... Chapter 2 + 3
-  Electrical installation..... Chapter 4
-  Maintenance..... Chapter 5

Original instructions



1. Product information

1.1. Designations used in these instructions	6
1.1.1. Designations used in these instructions.....	6
1.2. Application	6
1.3. Location requirements	7
1.3.1. Space requirements.....	7
1.3.2. Requirements for underlying surface.....	7
1.3.3. Condensation outlet.....	7
1.3.4. Requirements for duct system.....	7
1.4. Description	9
1.4.1. VEX unit design.....	9
1.4.2. Parts of the VEX unit.....	10
1.5. Principal dimensions, Horizontal VEX	11



2. Handling

2.1. Unpacking	13
2.2. Transport	13
2.2.1. Passage through openings.....	15
2.2.2. Internal transport with reduced weight.....	15



3. Mechanical assembly

3.1. Installation of Horizontal and Vertical VEX	18
3.1.1. Installation directly on floor.....	18
3.1.2. Integral mounting base	18
3.2. Condensation outlet	18
3.2.1. Establishment of condensation outlet.....	18
3.3. Water heating coil	19
3.3.1. Principles for connecting the water heating coil.....	19
3.3.2. MVM valve.....	21



4. Electrical installation

4.1. Electrical installation	23
---	-----------



5. Maintenance, hygiene and servicing

5.1. Maintenance	24
5.1.1. Overview of maintenance intervals.....	24
5.2. Hygiene (VEX100VDI only)	24
5.3. Servicing and cleaning	25
5.3.1. Filter replacement.....	25
5.3.2. Cleaning the fans.....	25
5.3.3. Cleaning the heating coils.....	25
5.3.4. Cleaning the crossflow heat exchanger.....	25
5.4. Airflow measurement	26
5.4.1. Determining airflow and pressure.....	26



6. Technical data

6.1. Weight, corrosion class, temperature ranges, etc	29
6.2. Panel filters	30

6.3. Water heating system.....	31
6.4. Capacity diagram.....	32
6.5. EC Declaration of Conformity.....	32
6.6. Ordering spare parts.....	32
6.7. Environmental declaration.....	33

Symbols, terms and warnings

Prohibition symbol



Failure to observe instructions marked with a prohibition symbol may result in serious or fatal injury.

Danger symbol



Failure to observe instructions marked with a danger symbol may result in personal injury and/or damage to the unit.

Scope

This instruction manual is for use with EXHAUSTO VEX-type air handling units. Please refer to the product instructions regarding accessories and extra equipment.

The instructions must be fully observed to ensure personal safety and to protect the equipment and ensure its correct operation. EXHAUSTO A/S accepts no liability for accidents caused by equipment not used in accordance with the manual's instructions and recommendations.

Supply air/extract air

This instruction manual uses the following terminology:

- Supply air
- Extract air
- Outdoor air
- Exhaust air

Accessories

The confirmation of order states which accessories are delivered with the VEX unit.

Horizontal and Vertical VEX



Lock the air handling unit during operation

The VEX unit must always be locked during operation:

- Use the cylinder lock in the handle. **Remember** to remove the key from the lock.
- Or use a padlock. Use the handle's built-in padlock fixture

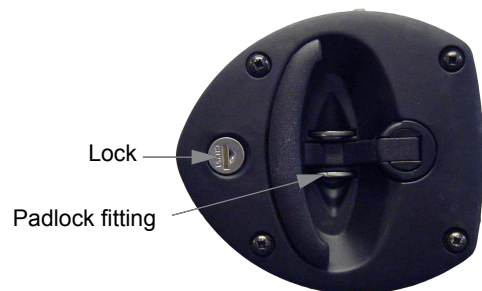

Warnings:

Opening the air handling unit



Do not open the service doors until the supply voltage has been disconnected at the isolation switch and the fans have stopped.

Prohibited uses



The VEX unit is not to be used to transport solid particles or in areas where there is a risk of explosive gases.

No duct connection







If one or more of the spigots is not connected to a duct: Fit a protective net to the spigots with a maximum mesh width of 20 mm (in accordance with EN294).

Rating plate

The VEX unit rating plate shows:

- VEX unit, type (1)
- production number (2)

 EXHAUSTO A/S <small>Company No. 26029953 Copenhagen - Denmark Phone: +45 8848 1100 - Mobile: +45 4506 1234</small>			
Type	V160HLECW2	 Icu = 10kA	
	No./Year 1234567/13		
Supply	Voltage: 3x400V+N+PE ~50Hz	Current: 23,5A	
HEAT	HCW		

NB

Always have the production number ready when contacting EXHAUSTO A/S.



1. Product information

1.1 Designations used in these instructions

1.1.1 Designations used in these instructions

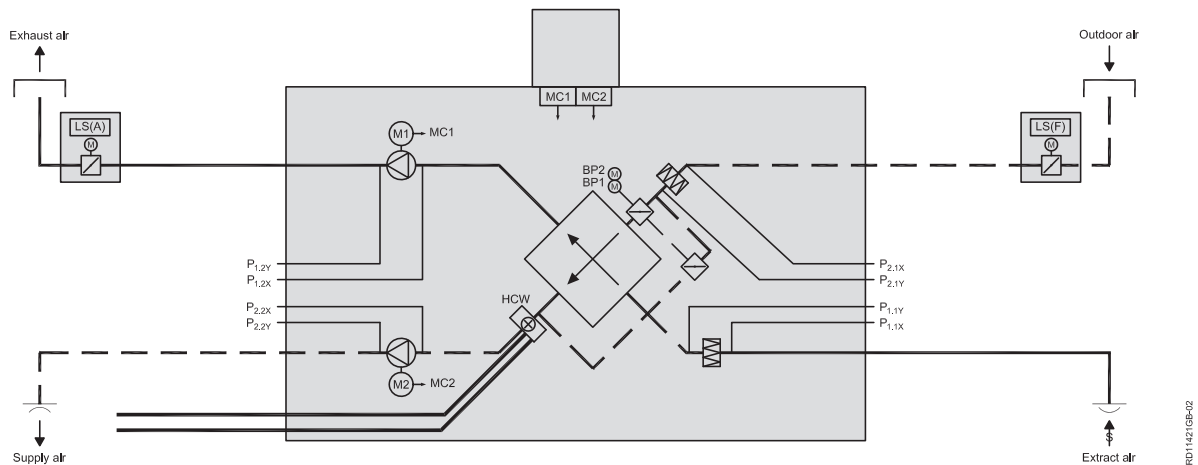

The simplified diagram shows a VEX unit with LEFT fan placement.

Component	Function
BP1	Bypass motor 1
BP2	Bypass motor 2
HCW	Water heating coil
LS (F)	Closing damper, outdoor air
LS (A)	Closing damper, exhaust air
MC1	Motor controller 1 for extract air motor
MC2	Motor controller 2 for supply air motor
M1	Extract air motor
M2	Supply air motor
P _{1.2X} and P _{1.2Y}	Points for measuring pressure rise across extract air fan
P _{2.2X} and P _{2.2Y}	Points for measuring pressure rise across supply air fan
P _{2.1X} and P _{2.1Y}	Points for measuring pressure loss across outdoor air filter
P _{1.1X} and P _{1.1Y}	Points for measuring pressure loss across extract air filter

1.2 Application

Comfort ventilation EXHAUSTO VEX is used for comfort ventilation tasks.
Operating temperature range for the unit – see section "Technical data".

Prohibited uses The VEX unit is not to be used to transport solid particles or in areas where there is a risk of explosive gases.

1.3 Location requirements

Location The air handling unit is designed for indoor fitting.

Outdoor **VEX100H:**The VEX100 horizontal model can be ordered for outdoor installation, in which case it is provided with a cover (accessory VEX100OD).

1.3.1 Space requirements

The drawing below indicates how much space is needed for opening the doors and servicing the unit, e.g. changing filters, cleaning, servicing, etc.

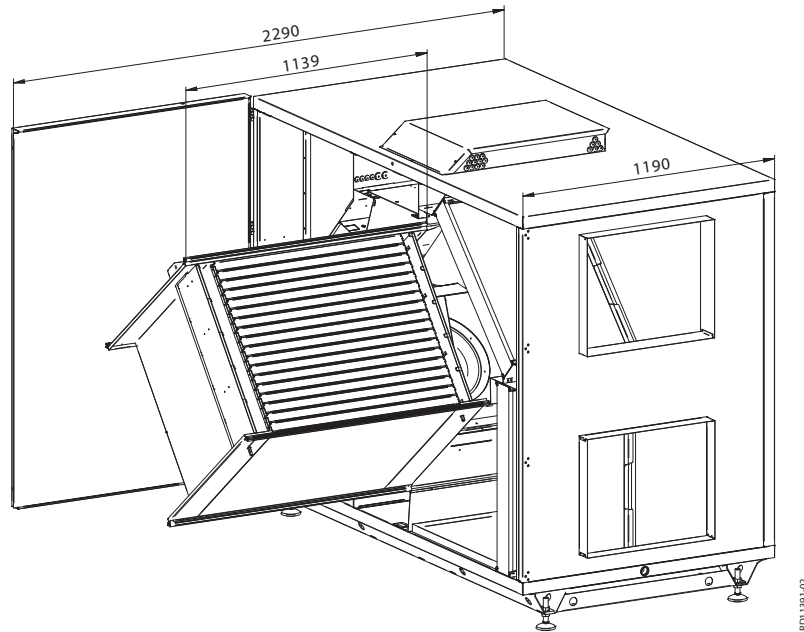

NB For servicing, the VEX must have a free height of at least 300 mm above the connection box.

1.3.2 Requirements for underlying surface

When floor-mounting the unit, the surface must be:

- flat
- level (+/- 3 mm per metre)
- hard
- resistant to vibration

1.3.3 Condensation outlet

A condensation outlet must be installed in the immediate vicinity of the unit. See also "Mechanical assembly" section.

1.3.4 Requirements for duct system

Connection to duct system To achieve maximum performance and minimal energy consumption, the unit should be connected to a straight duct at least 750 mm long, before and after the unit.

Silencers The duct system must be fitted with silencers specified by the Project Manager, which meet the requirements of the operating area.

Insulation

The duct system must be insulated against:

- condensation
 - sound
 - thermal loss
-

Condensation

Condensation in the ducts may occur when the exhaust/outdoor air has high humidity. EXHAUSTO recommends a condensation outlet is also fitted at the lowest point in the ducts.

Outdoor air intake

The outdoor air intake must be dimensioned with sufficiently low airflow to prevent rain and snow being drawn into the duct system.

No duct connection

If one or more of the spigots is not connected to a duct: Fit a protective net to the spigots with a maximum mesh width of 20 mm.

1.4 Description

1.4.1 VEX unit design

The following drawings show an overview of the design of left and right models of VEX units (shown without door).

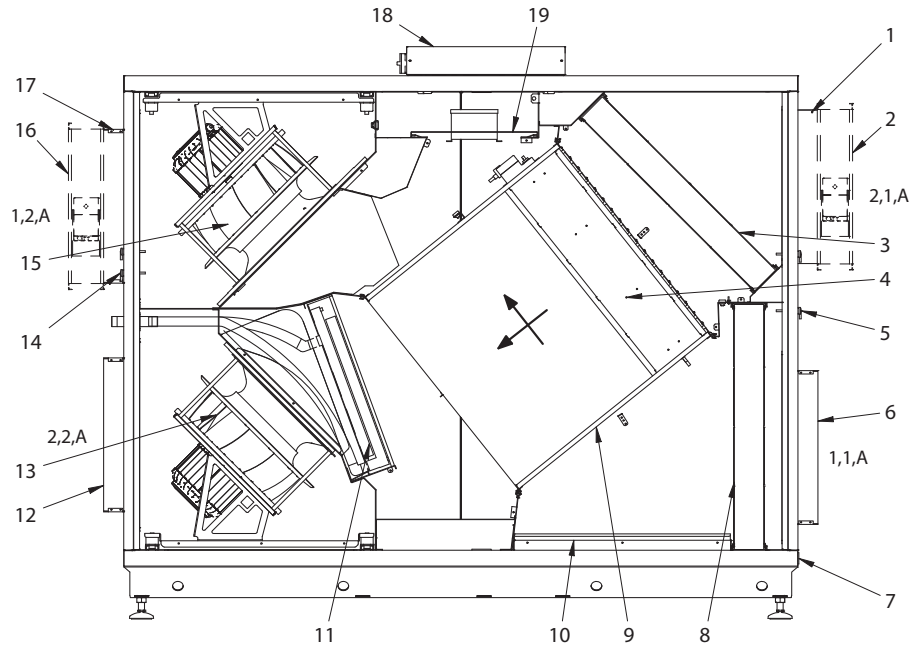

RD11486/03

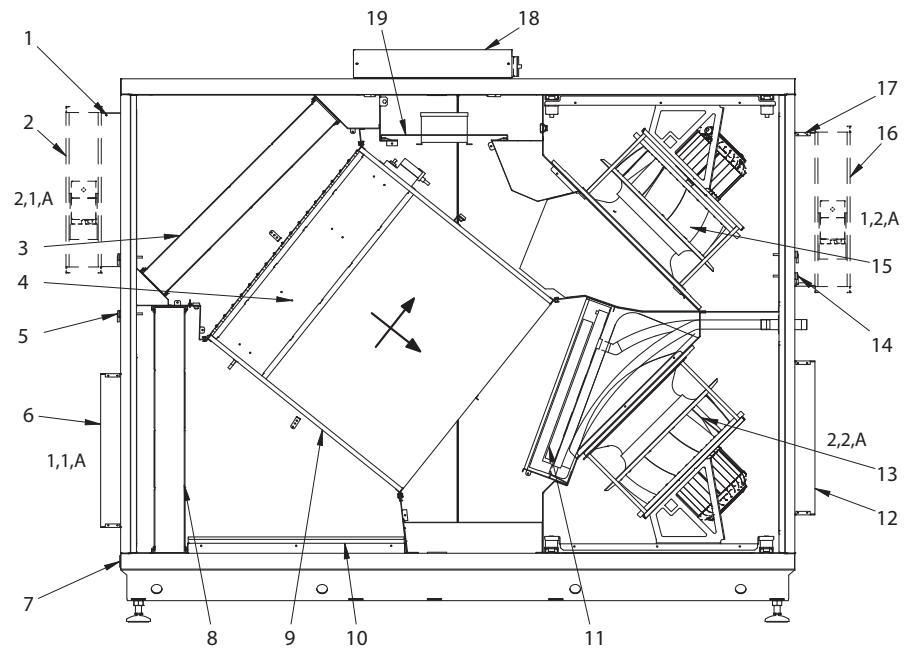

RD11487/03

Pos.	Part	Function
1	Spigot 2.1.A	Outdoor air spigot The spigot can also be positioned on the top of the air handling unit (2.1.B).
2	Closing damper LS	Closing damper - outdoor air, LSF
3	Outdoor air filter	Filters outdoor air
4	Bypass damper	For operation with heat recovery, the bypass damper is closed so that the air passes through the crossflow heat exchanger. For bypass operation, the damper is open, and the air bypasses the heat exchanger
5	Measurement socket	Measurement socket for pressure loss across the filters
6	Spigot 1.1.A	Extract air spigot
7	Condensation outlet	Channels condensate to the drain
8	Extract air filter	Filters extract air
9	Crossflow heat exchanger	Transfers heat from extract air to supply air
10	Condensation tray	Collects the condensate and drains it away from the crossflow heat exchanger to the condensation outlet.
11	Water heating coil with bleed screw	Heats supply air if heat recovery is insufficient.
12	Spigot 2.2.A	Supply air spigot. The spigot can also be positioned at the bottom of the air handling unit (2.2.B)
13	Supply air fan	For outdoor air/supply air
14	Measurement socket	Measurement socket for airflow calculation
15	Extract air fan	For exhaust air/extract air
16	Closing damper LS	Closing damper – exhaust air, LSA (accessory)
17	Spigot 1.2.A	Extract air spigot The spigot can also be positioned on the top of the air handling unit (1.2.B)
18	Connection box	Positioning of terminal board for electrical connection
19	Extraction plate	Positioning of motor controls

1.4.2 Parts of the VEX unit

Cabinet

The inside and outside of the cabinet are made of Aluzinc® The cabinet has been insulated with 50 mm mineral wool.

Fans

The unit contains two centrifugal fans with backward curved blades for extract air and supply air.

Crossflow heat exchanger

The crossflow heat exchanger in the unit is mounted with a modulating bypass damper. The crossflow heat exchanger can be removed for cleaning.

Filters

The unit includes integral panel filters for both extract air and supply air.

1.5 Principal dimensions, Horizontal VEX

VEX170H, Left

The following drawing gives the principal dimensions:

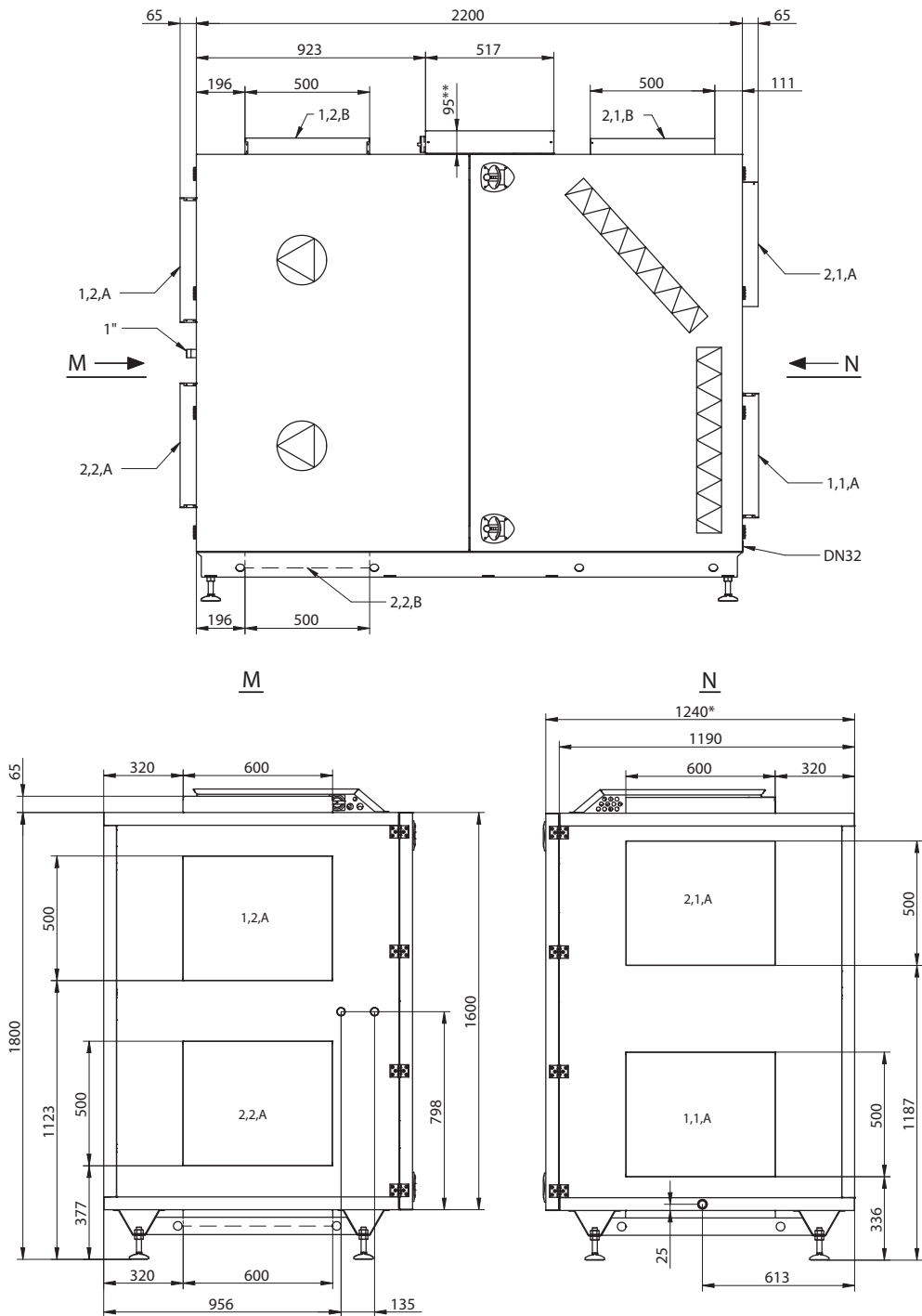

RD11370-02

NB

The drawing shows all of the spigot positioning options.
 * Allow a distance for service in front of the unit equivalent to the unit depth.
 ** Allow a min. of 300 mm free height for service.

VEX170H, Right

The following drawing gives the principal dimensions:

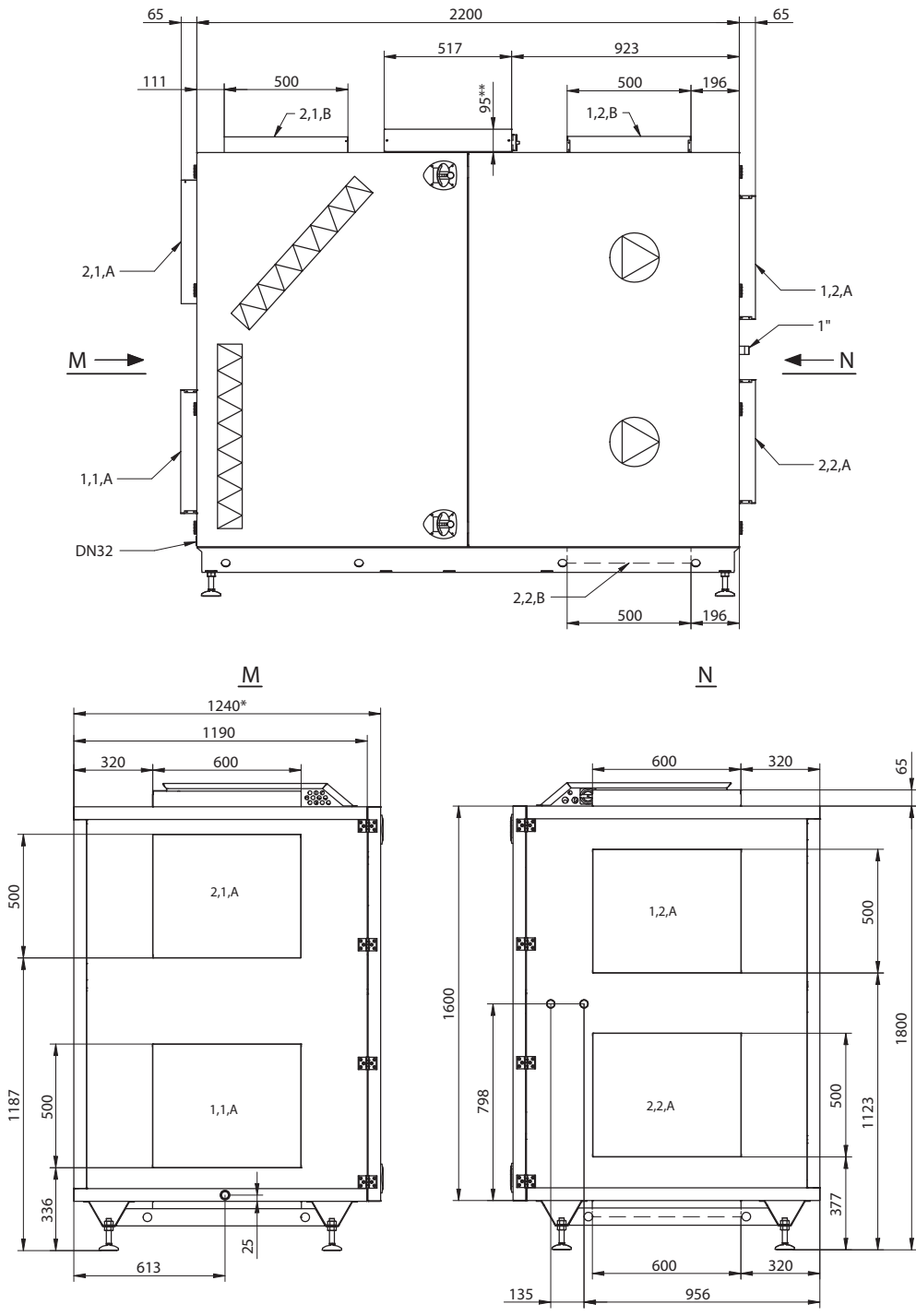

RD11397-02

NB

The drawing shows all of the spigot positioning options.
 * Allow a distance for service in front of the unit equivalent to the unit depth.
 ** Allow a min. of 300 mm free height for service.



2. Handling

2.1 Unpacking

Supplied components

The following components are supplied:

- VEX unit
- Supplied accessories (as indicated in the checklist on the front page of the instructions).

Packaging

The unit is delivered on a disposable pallet and packed in clear plastic.

NB

Once the plastic has been removed, the unit must be protected against dirt and dust:

- **The covers on the spigots must not be removed until the spigots are connected to the ventilation ducts.**
- **Whenever possible, keep the unit closed during fitting.**

The unit should be cleaned before it is used.

Once the VEX unit is fitted, it must be checked and thoroughly cleaned. All dust, debris and metal shavings must be vacuumed up.

2.2 Transport

Transport

Transport the VEX unit on the disposable pallet. Do not lift it with the spigots or connection box.

Transport methods

Transport the VEX unit in one of the following ways:

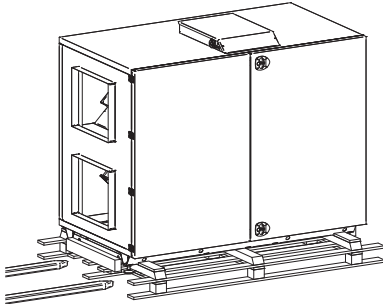
Method	Drawing
<p>Using pallet truck or fork-lift truck:Lift the VEX unit on the disposable pallet</p>	

Method	Drawing
<p>Note - without disposable pallet There is a risk of damaging the base of the unit if the forks on the lifting equipment are insufficiently long and the disposable pallet is not used.</p>	
<p>Pallet truck or fork-lift truck - without disposable pallet: Use one of the two following methods for lifting, see drawings.</p>	

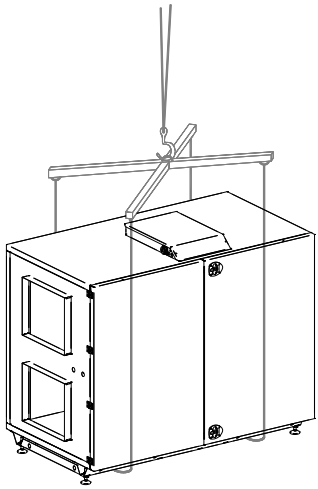
Method	Drawing
<p>Crane: Use straps and lifting yokes to prevent damage to the unit.</p>	

2.2.1 Passage through openings

Height The height of the VEX is 1895 mm.

Width The list (below) shows how wide the opening has to be for the unit to pass through:

If the opening width is ...*)	Response
less than 1200 mm	the unit will not pass through.
between 1200 and 1250 mm	remove doors, see relevant section.
greater than 1250 mm	the unit can pass through.

*) Measurements are based on the exact dimensions of the VEX unit.

2.2.2 Internal transport with reduced weight

Weight reduction The weight can be reduced during transport by removing service doors, fans and crossflow heat exchanger. The table below shows the how much weight can be reduced by removing the various parts.

Parts	Weights, VEX170H
Fan, 2 items at	36 kg = 72 kg
Crossflow heat exchanger, 1 item at	124 kg
Doors, 2 items at	29 kg = 58 kg
Total weight	665 kg

Removing the service doors

To remove the service doors:

- Open both doors.
- Using a small punch or similar tool, knock the pin out of the top of the door hinges (A), and lift the doors off.

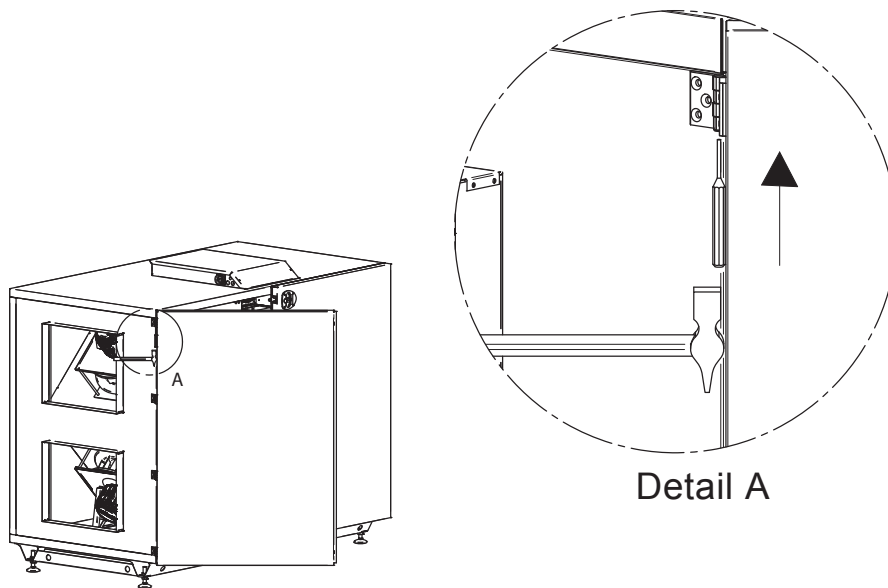

RD11359-02

To remove the fan unit

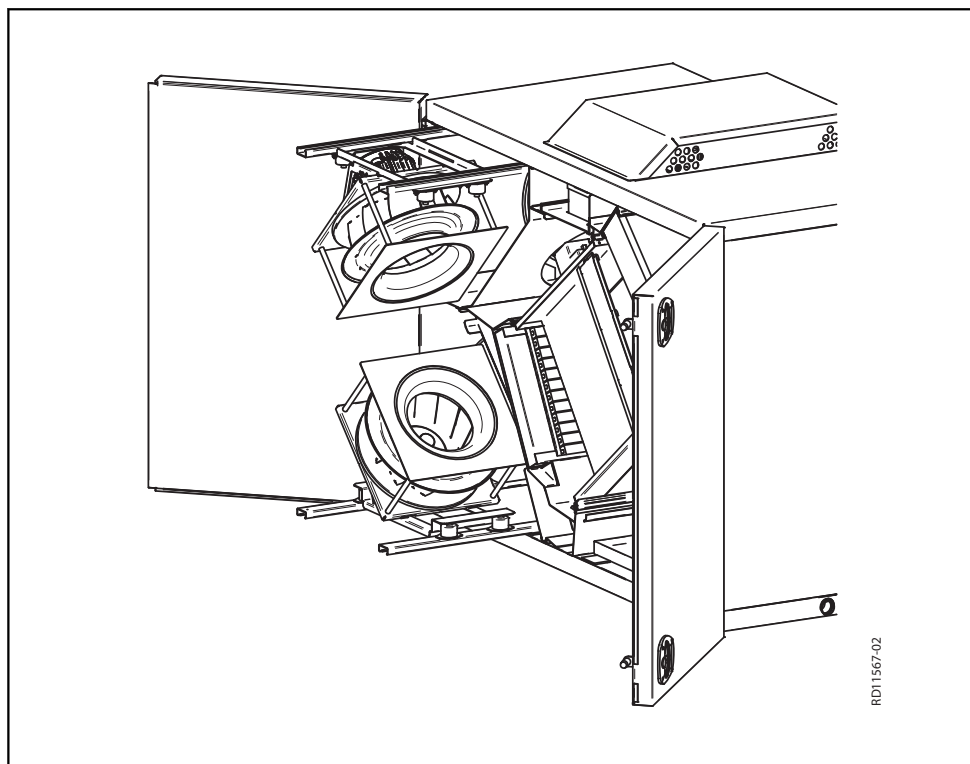

RD11567-02

Step	Action
1	Remove the fixing screw from the sliding rail, and release the ties on the motor cable.

2	Pull the fan unit out to the stop (two screws) on the sliding rail.
3	Dismount the motor cable from the motor control on the sliding panel and pull it towards the motor through the rubber grommets.
4	Remove the two sliding rail screws. The fan unit can now be lifted off.

Dismounting

See section "Maintenance" for instructions for dismounting fans and crossflow heat exchanger and for removal of filters.

Note weight



The fan units weigh 36 kg each - requiring at least two persons to lift each unit.



3. Mechanical assembly

3.1 Installation of Horizontal and Vertical VEX

Description It is important that the VEX is installed on a level surface, as this affects the collection and draining of the condensate.

3.1.1 Installation directly on floor

The requirements for the floor surface must be met, see the section entitled "Requirements for underlying surface".

NB After installation, check the VEX unit is completely level.

3.1.2 Integral mounting base

The EXHAUSTO integral mounting base enables the air handling unit to be installed correctly. The base is equipped with adjustable machine shoes, so that the air handling unit can be fitted horizontally on a surface that is not level (+/- 20 mm per metre).

3.2 Condensation outlet



Connection of the condensation outlet must be made by an authorised plumber.



Drain the condensation outlet into a floor gully or similar. The condensation outlet must be fitted with a water trap. See below.

Risk of frost



Where there is a risk of frost: It is recommended to protect the condensation outlet against frost damage. Fit a SIPHONE electrical heat tracing device on the outlet before the pipes are insulated. For fitting, see the device's fitting instructions.

3.2.1 Establishment of condensation outlet

Location The following two drawings show examples of how the drain from the condensation outlet can be established and the correct dimensions for the water trap:

Solution with siphon water trap (accessory)

The siphon water trap is easy to install and service.

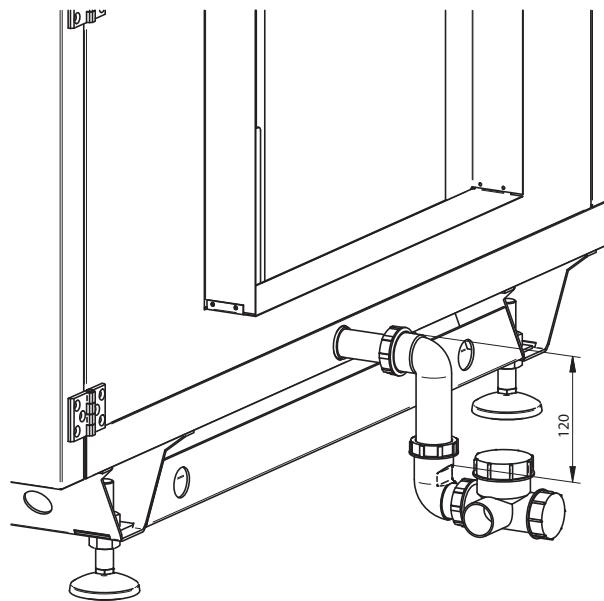

RD13443-01

Solution with HT pipe

Use HT pipe (HT, DN32, DIN4102), if the above solution is not employed (not supplied by EXHAUSTO).

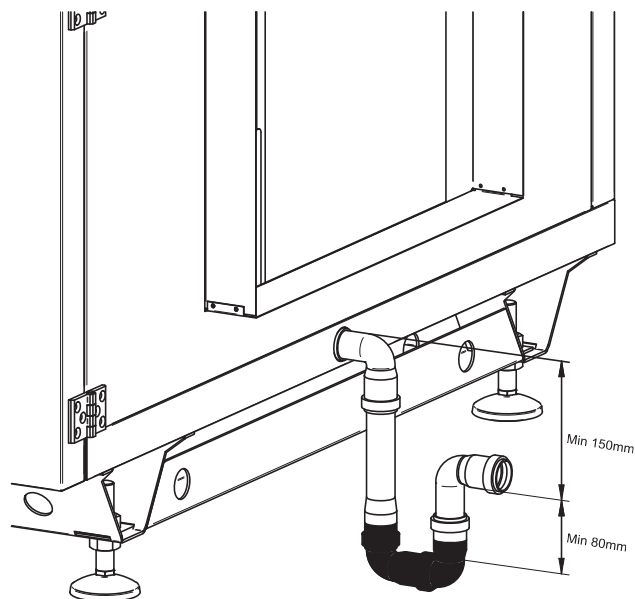



RD11400-02

3.3 Water heating coil

3.3.1 Principles for connecting the water heating coil

Mixing loop

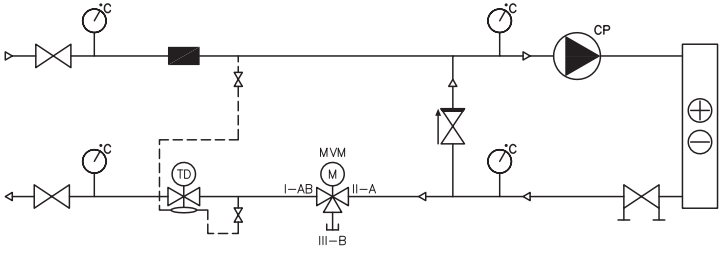
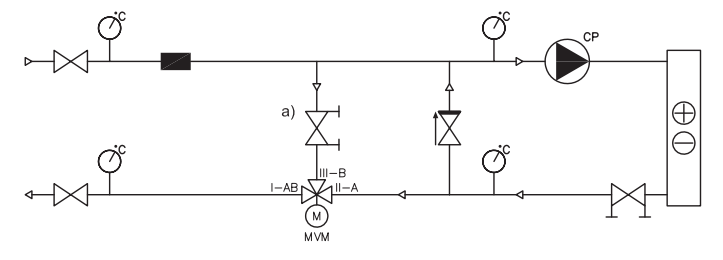
The diagrams below are simplified. The dimensioning of valves, pipes, etc. and heating coil connection must always be carried out by authorised fitters in accordance with applicable regulations and legislation.

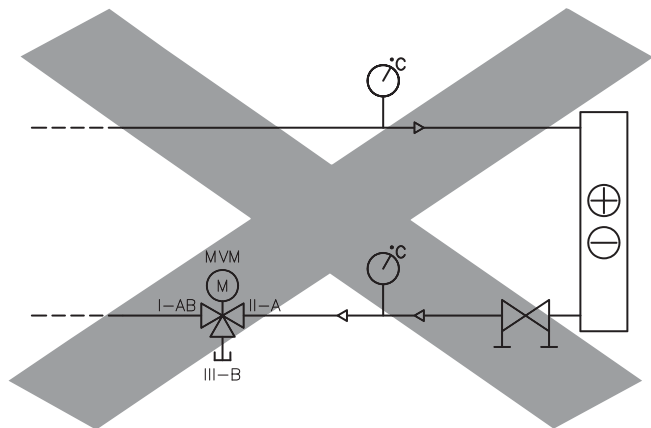
Type	Principle	Simplified diagram
<p>Mixing loop 1</p>	<p>Variable flow in the primary circuit (supply) and constant flow in secondary circuit (VEX unit)</p>	
<p>Mixing loop 2</p>	<p>Variable flow in the primary circuit (supply) and constant flow in secondary circuit (VEX unit)</p> <p>a) When there is no heating requirement, valve adjustment must be based on the required primary circuit water flow</p>	
	<p>Do not connect the heating coil like this!</p> <p>Connection without circulation pump risks frost damage!</p>	

RD12542-02

RD12500-03

Explanation of simplified diagram

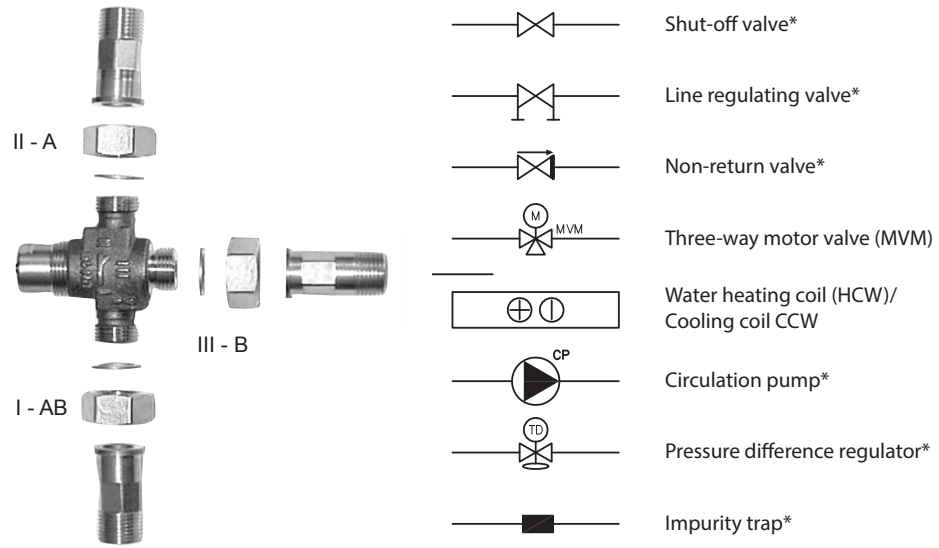

RD12642GE-02

*) not EXHAUSTO delivery (refer to the technical specifications in section 7).

Bleeding

Following connection of water supply to the unit:

- Bleed the system thoroughly using the upper bleed screw on the water heating coil

Insufficient bleeding



Insufficient bleeding can result in still water forming in the system, which may result in frost-induced leaks during the winter.

Fitting motor valve



The valve must not be fitted with the motor facing down

Insulate the supply pipe and heating coil



The pipes and post-heating coil must be insulated according to applicable regulations

3.3.2 MVM valve

Screening

Screen the valve motor from direct sunlight. Due to heat emissions, the valve motor must not be encapsulated (max. ambient temperature: 50°C).

Insulating the valve

To ensure normal operation at ambient temperatures below 0°C, it is very important that the valve section is insulated according to current standards/procedures.

MVM-OD, valve for outdoor fitting

If MVM-OD (MVM intended for outdoor fitting) is used, the screening and insulation are part of the delivery. MVM-OD is only possible for valve sizes below 6.3 K_{VS}.

Regulating properties

Optimal regulation is achieved when the differential pressure is between 5–20 kPa. See section "Technical specifications" to calculate K_{VS}.

Heat supply

The heat supply **must** be constant.

MVM-OD, valve for outdoor fitting

Horizontal VEX: If MVM_OD (MVM designed for outdoor fitting) is used, the screening and insulation are part of the delivery. MVM-OD option only available with valve sizes below 6.3 Kvs.



4. Electrical installation

4.1 Electrical installation

See the attached instructions "Guide to Electrical Installation of VEX170-X with water heating coil".



5. Maintenance, hygiene and servicing

5.1 Maintenance

5.1.1 Overview of maintenance intervals

The following chart details the recommended maintenance intervals for the VEX. The intervals are a guide and based on normal operation. EXHAUSTO recommends maintenance is adjusted to match the actual operating requirements.

Component	Procedure	Twice a year	Once a year
Filters*	Filter replacement: Recommended that both filters are replaced at the same time. Filters should be replaced at least:	X	
Filter monitor	Check that all the seals in the filter monitor are tight		X
Seals and sealing strips	Check that all the seals are tight		X
Fan	<ul style="list-style-type: none"> Check that the fan impeller is securely fixed to the shaft. Removal of fan unit. See section "Internal transport with reduced weight" Cleaning. See section "Servicing and cleaning" 		X
Crossflow heat exchanger	Clean the heat exchanger. See section "Cleaning of heat exchanger"		X
Bypass damper	Check damper function		X
Heating coil	Clean the heating coil. See section "Cleaning of heating coil"		X
Closing damper	Check damper function		X
Condensation outlet	Check that the outlet functions by pouring water in the condensation tray		X
Motor valve/circulation pump	Check function		X

*Filters



Only use original EXHAUSTO filters

- The provided filter data (section "Technical data") are based on the use of original EXHAUSTO filters
- Eurovent certification is only valid if original filters are used.
- Use of non-original filters may cause leakage in the VEX unit, impair filter function and cause an extraordinary pressure drop.
- EXHAUSTO recommends that you register the filter replacement date to ensure filters are replaced at the correct intervals.

5.2 Hygiene (VEX100VDI only)

VDI6022 air hygiene standard

To ensure that the VEX100 meets the requirements of the VDI6022 hygiene standard, its design ensures that:

- bacterial growth and dirt accumulation are minimal
- conditions for cleaning are optimum

Filter ePM₁ 55%

The outdoor air side of the unit must as a minimum be fitted with an ePM₁ 55% filter (F7) to meet VDI 6022 requirements.

5.3 Servicing and cleaning

5.3.1 Filter replacement



Disconnect power at the isolation switch before opening the door.

Pull the filters out. Remember to check the flow direction - see the arrows on the filter.

Discarded filters must be stored immediately in sealed plastic bags and disposed of responsibly.

5.3.2 Cleaning the fans



Step	Action
1	Switch off the power supply to the air handling unit at the isolation switch before opening the doors.
2	Pull out the fan section: Loosen the fixing screw on each sliding rail and loosen the bindings on the motor cables. Pull the fan unit out to the stop (two screws) on the sliding rails.
3	Clean the fan impeller with a vacuum cleaner and wipe down with a damp cloth if necessary. Clean the blades on the fan impeller carefully to avoid disrupting the balance. If there are weights on the fan impeller, these must not be removed.
4	After cleaning the fan impeller, check that the unit does not vibrate when operating.
Checking measuring socket hoses	
5	Remove the hoses at the measuring sockets.
6	Blow air through the hoses to remove any impurities.

5.3.3 Cleaning the heating coils

Step	Action
1	Switch off the power supply to the air handling unit at the isolation switch before opening the door(s).
2	Vacuum clean the heating coil
3	Check that the fins on the heating coil are not deformed.
	<p>The fins are sharp.</p>

5.3.4 Cleaning the crossflow heat exchanger

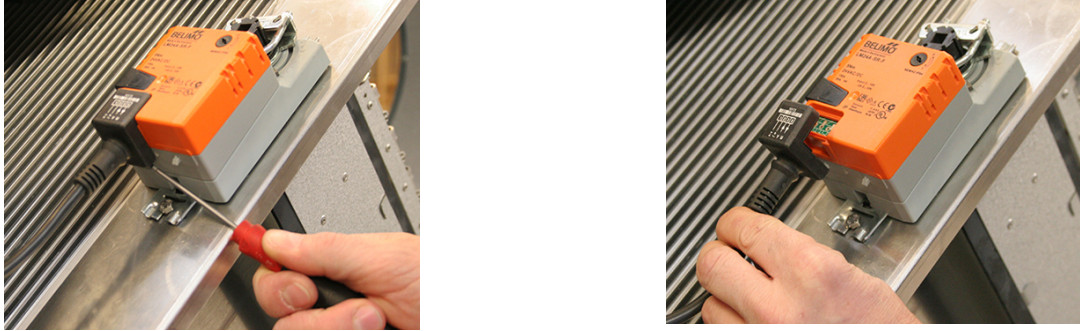
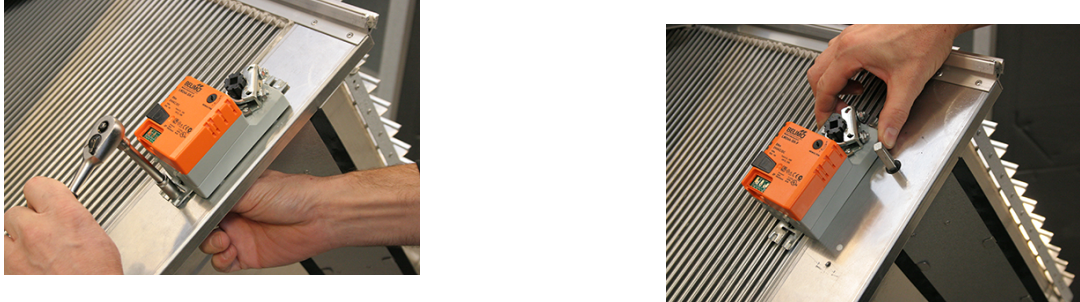
Step 1-9	Action
1	Switch off the power supply to the air handling unit at the isolation switch before opening the doors.

Step 1-9	Action
2	<p>There are two bypass motors on the crossflow heat exchanger. Slightly pull the heat exchanger out of the VEX and remove the plug from each bypass motor. Hold down the split pin under the plug using a screw driver, see images:</p> 
3	<p>Remove the crossflow heat exchanger. Note the weight of the heat exchanger, see technical data – min. two people when lifting.</p>
4	<p>Press the release button on the bypass motor and turn the damper, so that the louvres are in open position.</p>
5	<p>The bypass motors must be dismantled before cleaning the heat exchanger with water, see photos:</p>  <p> Do not activate the release button on the bypass motor while it is dismantled, as this will alter the position of the motor compared to the damper.</p>
6	<p>Clean the heat exchanger by flushing with hot water or by pressure hosing. Max. water temperature 90°C.</p>
7	<p>Mount the bypass motors. The damper must be in the same position (louvres fully open) as when it was removed.</p>
8	<p>Shut the louvres, and replace the heat exchanger.</p>
9	<p>Re-insert the plug for the bypass motors.</p>

5.4 Airflow measurement

5.4.1 Determining airflow and pressure

Use the formulae in the table to calculate airflow and pressure drop over the filters.

Airflow:	Airflow q_V (l/s, m ³ /h) can be read from the differential pressure Δp_M [Pa]
Extract air	$\Delta p_{M1.2} = P_{1.2X} - P_{1.2Y}$ [Pa]
Supply air	$\Delta p_{M2.2} = P_{2.2X} - P_{2.2Y}$ [Pa]

Pressure drop across:	
Extract air filter	$\Delta p_{1.1} = P_{1.1X} - P_{1.1Y} \text{ [Pa]}$
Supply air filter	$\Delta p_{2.1} = P_{2.1X} - P_{2.1Y} \text{ [Pa]}$

Location of measurement points

The location of measurement points is shown on the drawing. The exterior measuring points positions on the VEX are shown in the drawings in the section "Description".

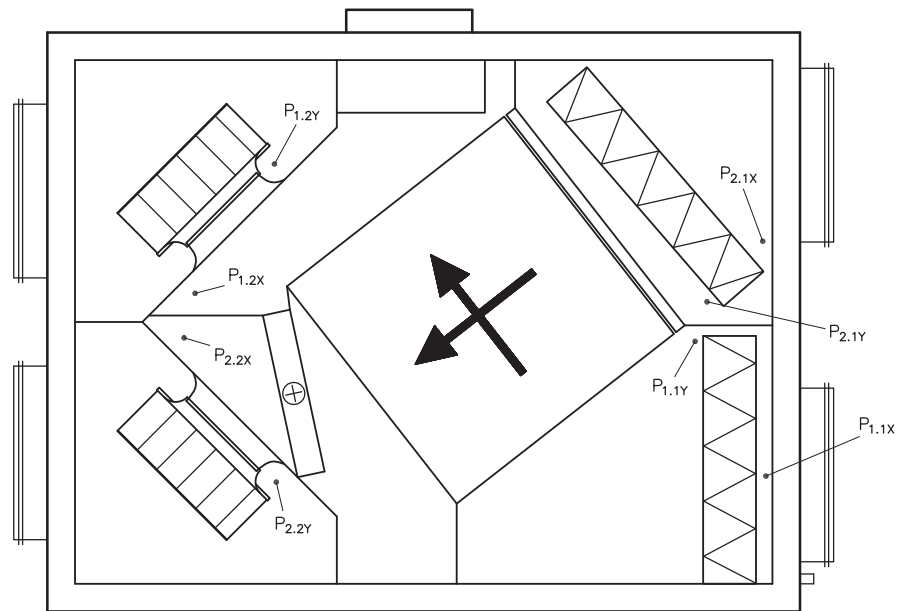

5406560-01

Supply air

Supply airflow diagram:

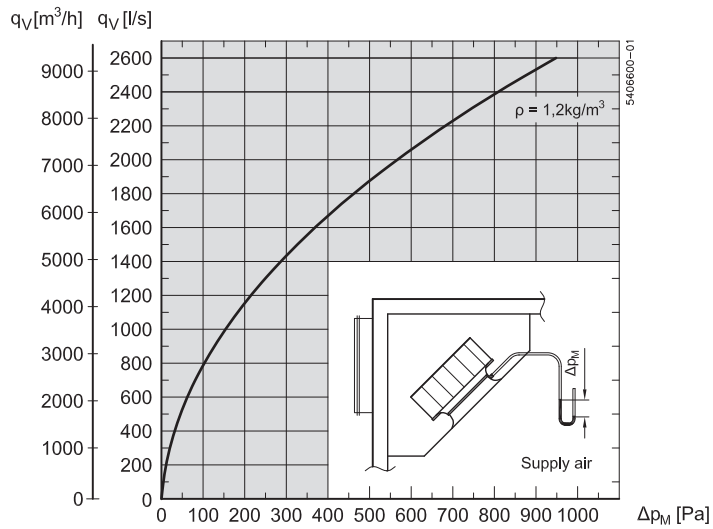

— Airflow (q_V) according to pressure difference (Δp_M)

$$\left. \begin{aligned} q_V &= 234,0 \cdot \sqrt{\frac{2 \cdot \Delta p_M}{\rho}} \text{ [m}^3/\text{h]} \\ q_V &= 65,0 \cdot \sqrt{\frac{2 \cdot \Delta p_M}{\rho}} \text{ [l/s]} \end{aligned} \right\} \pm 10\% \text{ for } \Delta p_M > 40 \text{ Pa}$$

Extract air

Extract airflow diagram:

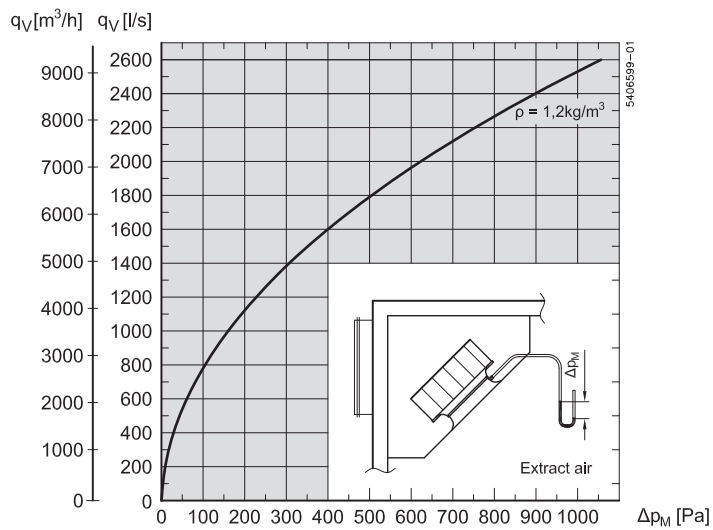

— Airflow (q_V) according to pressure difference (Δp_M)

$$\left. \begin{aligned} q_V &= 223,2 \cdot \sqrt{\frac{2 \cdot \Delta p_M}{\rho}} \text{ [m}^3/\text{h]} \\ q_V &= 62,0 \cdot \sqrt{\frac{2 \cdot \Delta p_M}{\rho}} \text{ [l/s]} \end{aligned} \right\} \pm 10\% \text{ for } \Delta p_M > 40 \text{ Pa}$$



6. Technical data

6.1 Weight, corrosion class, temperature ranges, etc.

Weight

VEX total weight	665 kg
Doors	2 x 29 kg
Crossflow heat exchanger	124 kg
Fan unit	2 x 36 kg
VEX for transporting into building (without doors, heat exchanger and fan unit)	411 kg

Corrosion class

Corrosion class	Corrosion class C4 in accordance with EN ISO 12944-2
-----------------	--

Temperature ranges

Outdoor air temperature	-40°C to +35°C
Ambient temperature	-30°C to +50°C

At temperatures below -25°C (with outdoor installation), use of a thermostatically controlled heater in the automated control box is recommended.

Motor damper

Motor damper type	LS (closing damper)	LSR (closing damper, spring return)
Type	LS500-60024	LSR500-60024
Designation	LSA/LSF	LSFR
Motor type	NM24-F	AF-24
Rotation time	75–150 s	open: 150 s close: 16 s
Ingress protection	IP42	IP42
Ambient temperature	-20°C to +50°C	-30°C to +50°C
Damper depth	100 mm	100 mm

6.2 Panel filters

Data	VEX170		Device
	ePM ₁₀ 50%	ePM ₁ 55%	
Dimensions: h x w, 1 item per air direction	800 x 564		mm
Panel filter thickness	96		mm
Temperature resistant to	70		°C
Filter class according to ISO 16890	ePM ₁₀ 50%	ePM ₁ 55%	
Filter class according to EN 779	M5	F7	

Final pressure drop For the final pressure drop over the filter, the lower of the following two methods is recommended.

- Final pressure drop = 3 x initial pressure drop
- Final pressure drop = initial pressure drop + 100 Pa

6.3 Water heating system

Water heating coil

		HCW
Weight	Weight without fluid	16.3 kg
	Water content	4.6 l
Dimensions	Face area (h x b)	550 x 1,042 mm
Data	Test pressure	3000 kPa
	Max. operating pressure	1000 kPa
	Number of rows of pipes	qty. 2
	Number of circuits	qty. 11
	Pipe connection	DN25 (1")
	Fin spacing	2 mm
	Permissible media temperature	5..0.95°C

Recommendation



A precise calculation of the heating coil is recommended, to be carried out with calculation program EXselect, available on www.exhausto.dk.

6.4 Capacity diagram

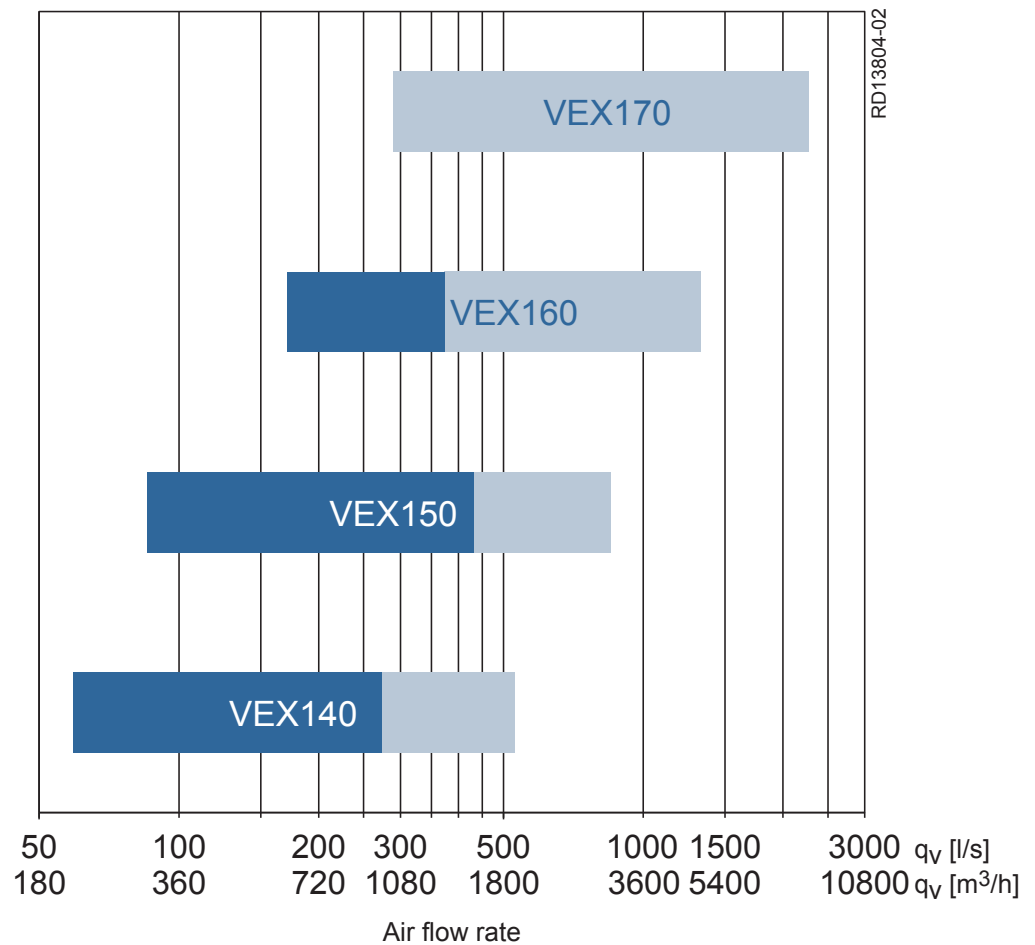

Recommendation



You are recommended to make a more precise calculation of the unit's capacity with the EXselect calculation program, available on the EXHAUSTO website.

6.5 EC Declaration of Conformity

The document is located in the door of the VEX unit. It is also available on the EXHAUSTO website by searching under the document or order number.

6.6 Ordering spare parts

Find production number

When ordering spares, please state the relevant production part number. This will ensure that the correct parts are delivered. The production number is given on the front of the VEX guidelines and on the VEX rating plate.

Contact: Contact your local EXHAUSTO office service department to order a spare part. Contact information is given on the back cover of these instructions. See also the "Layout" section for an overview of the position and designation of parts in the VEX.

6.7 Environmental declaration

Environmental documentation The unit can be disassembled into individual product parts when outworn and in need of disposal.

Product parts	Material	Handling
Sheet parts	Aluzinc	For recycling after disassembly
Condensation tray	Stainless steel	For recycling after disassembly
Bypass dampers, heat exchangers and metal sections	Aluminium	For recycling
Insulation	Mineral wool	For recycling after disassembly
Door gasket	CFC and HCFC-free cellular rubber	Dumping or incineration
Fan motors, bypass motors	Aluminium, steel, copper and plastic	For recycling after disassembly
Control unit	Electronic components	For recycling by an authorised enterprise
Cassette filter	Fibreglass and plastic	Dumping or incineration
Unit is supplied on disposable pallets	Wood	Dumping or incineration

Percentage weight

Handling	Percentage weight of materials per unit
For recycling	11% (mineral wool)
For recycling	85% (63% Aluzinc, 16% aluminium, 3.5% steel/iron, 2% stainless steel and 1% copper)
Dumping or incineration	2% (Wood, filter paper, cellular rubber)
Other	1.5% (electronic components)
Total	100%



Scan code and go to addresses at
www.exhausto.com