

GB

VEX280HX without control system

Mechanical installation instructions

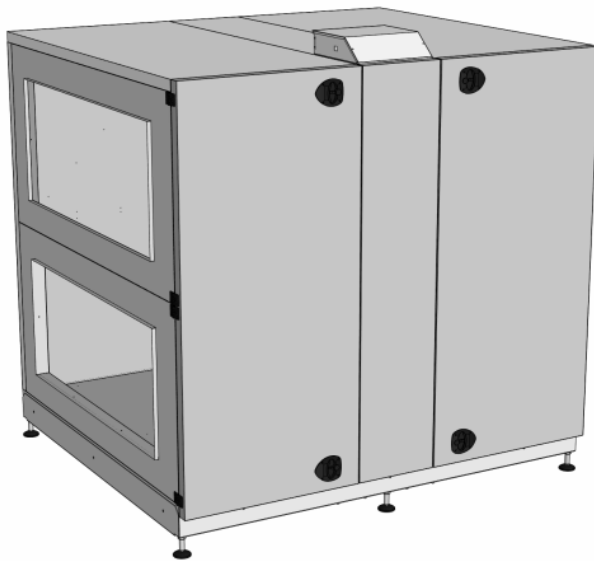

Unit supplied with (factory fitted):

- Rotor with standard temperature efficiency
- Rotor with high temperature efficiency
- Compact filters FP
- Bag filter FB
- Trim damper and blowout zone, TB280
- OD (roof for outdoor)





The following accessories are supplied separately:

- HCW heating coil
- HCE heating coil
- CCW cold water coil
- DX cooling/heating coil
- Mounting base, MSVEX280H
- Closing damper, LS600x1400, (LSA exhaust)
- Closing damper, LS600x1400, (LSF outdoor)
- Closing damper, LSR600x1400, with spring-return (LSFR outdoor)

Serial no.: _____

Prod. order no.: _____

Sales order no.: _____

-  Product information..... Chapter 1 + 6
-  Mechanical assembly..... Chapter 2 + 3
-  Electrical installation..... Chapter 4
-  Maintenance..... Chapter 5

Original instructions



1. Product information

1.1. Model overview	5
Model overview.....	5
1.2. Designations used in these instructions	7
1.2.1. Designations used in these instructions.....	7
1.3. Application	7
1.4. Location requirements	7
1.4.1. Spatial requirements.....	8
1.4.2. Requirements for underlying surface.....	8
1.4.3. Requirements for duct system.....	8
1.5. Description	9
1.5.1. The VEX unit design.....	9
1.6. Principal dimensions	12
VEX280, V1.....	12
VEX280, V2.....	13



2. Handling

2.1. Unpacking	14
2.2. Transport	14
2.2.1. Weight.....	14
2.2.2. The VEX sections' principal dimensions.....	14
2.2.3. Internal transport with reduced weight.....	15



3. Mechanical assembly

3.1. Installing the unit	17
3.1.1. Assembly instructions	17



4. Electrical installation

4.1. Electrical installation	21
---	-----------



5. Maintenance

5.1. Maintenance chart	22
5.2. Service	22
5.2.1. Filter change.....	22
5.2.2. Servicing and cleaning.....	23
5.3. Airflow measurement	23
5.3.1. Determining airflow and pressure.....	23



6. Technical specifications

6.1. Weight, corrosion class, temperature ranges, etc	27
6.2. Compact filters	28
6.3. Bag filters	29
6.4. Capacity diagrams	30
6.5. Ordering spare parts	30

Symbols, terms and warnings

Prohibition symbol  Failure to observe instructions marked with a prohibition symbol may result in serious or fatal injury.

Danger symbol  Failure to observe instructions marked with a danger symbol may result in personal injury and/or damage to the unit.

Scope

This instruction manual is for use with EXHAUSTO VEX-type air handling units. Please refer to the product instructions regarding accessories and extra equipment.

The instructions must be fully observed to ensure personal safety and to protect the equipment and ensure its correct operation. EXHAUSTO A/S accepts no liability for accidents caused by equipment not used in accordance with the manual's instructions and recommendations.

Supply air/extract air

These instructions use the following terms as given in DS447-2013:

- Supply air (air blown in)
- Extract air (air removed)
- Outdoor air
- Exhaust air

Left/Right

The term R for Right, indicates the supply air is to the right of the cooling unit, as seen from the operating side. The term L for Left, indicates the supply air is to the left.

Front page: Accessories

The front page of the instruction manual contains a checklist, detailing the accessories delivered with the VEX unit.

NB

When retrofitting EXHAUSTO accessories, please update the checklist on the front page.

Warnings

Opening the unit



Do not open the service doors before the supply voltage has been disconnected at the isolation switch and the ventilators have stopped.

Prohibited



The VEX unit must not be used to transport solid particles or in areas where there is a risk of explosive gases.

No duct connection



If one or more of the spigots is not connected to a duct: Fit a protective net to the spigots with a maximum mesh width of 20 mm (in accordance with EN 294).

Lock the air handling unit during operation

The VEX unit must always be locked during operation:

- Use the cylinder lock in the handle. **Remember** to remove the key from the lock.
- Or use a padlock. Use the handle's built-in padlock fixture.

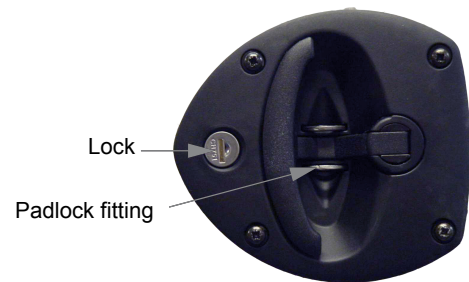

Rating plate

The VEX unit rating plate shows:

- VEX unit, type (1)
- production number (2)

EXHAUSTO		CE	
<small>Østernvej 76 · DK-5550 Langeskov · Danmark Telefax +45 6565 1110 · Telefon +45 6566 1234</small>			
Type	V280H2EA2	$I_{cu} = 10kA$	1
	No./Year 1234567/2016		2
Supply	Voltage: 3x400V+N+PE ~50Hz	Current: 34A	
ECO design	$\eta = 59,0\%$ (A) N62 (2015) N = 65,1 VSD integrated		

NB

Always have the production number ready when contacting EXHAUSTO A/S.



1. Product information

1.1 Model overview

Model overview

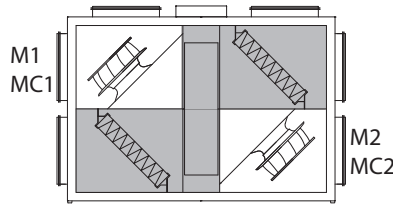

Positioning of fan, motor (M) and motor control (MC)

Fan placement 1 (V1)

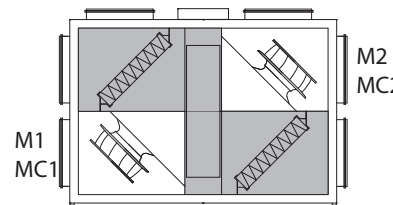

Fan placement 2 (V2)

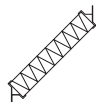

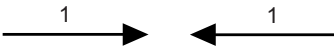
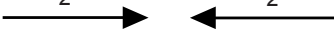
Elements	Description
	Fan
	Compact filter
	Bag filter
1,1,A or B	Extract air spigot
1,2,A or B	Exhaust air spigot
2,1,A or B	Outdoor air spigot
2,2,A or B	Supply air spigot
	Air direction, extract air
	Air direction, supply air

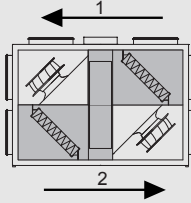
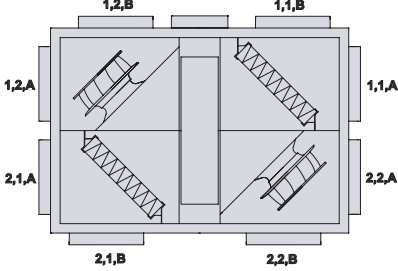
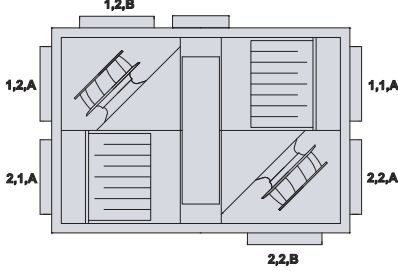
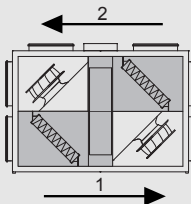
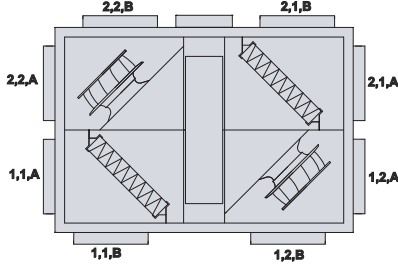
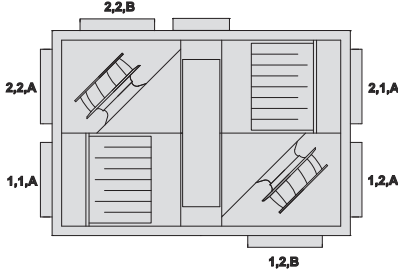
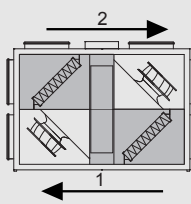
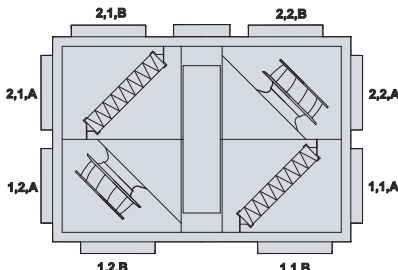
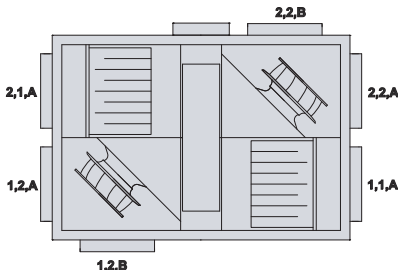
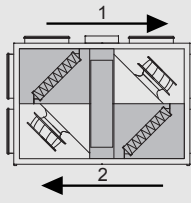
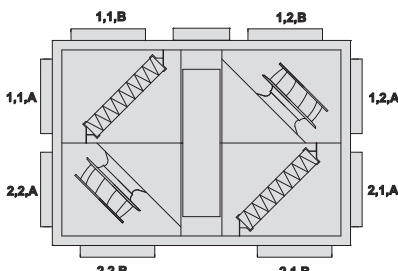
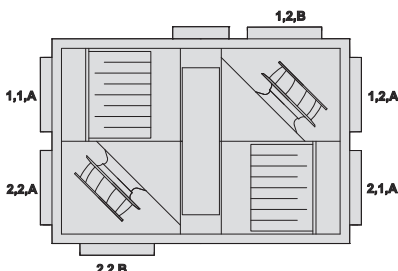
Optional spigot positions in relation to fan placement and filter type		
Fan placement and airflows	Compact filters	Bag filters
<p>Fan placement 1, Right</p> 		
<p>Fan placement 1, Left</p> 		
<p>Fan placement 2, Right</p> 		
<p>Fan placement 2, Left</p> 		

1.2 Designations used in these instructions

1.2.1 Designations used in these instructions

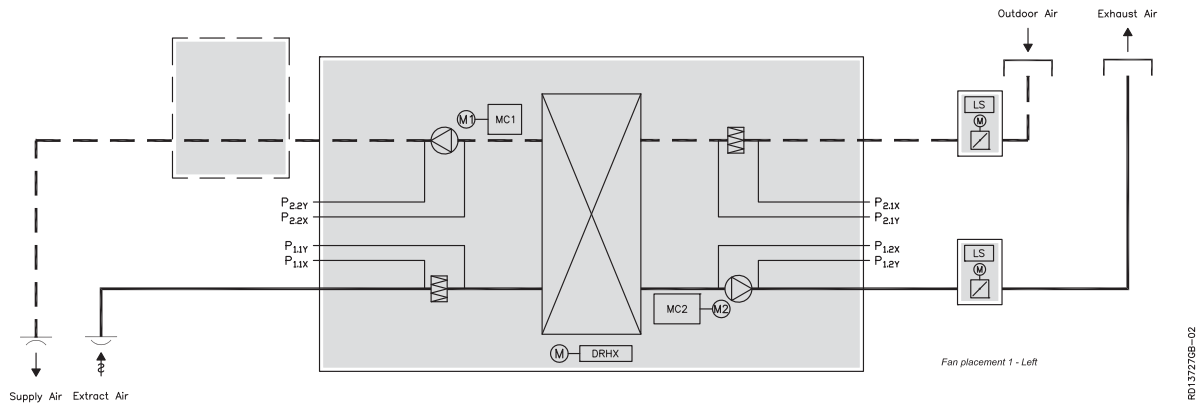

The simplified diagram shows a VEX unit with fan location 1, Left

Component	Function
MC1	Motor control, motor 1 (extract air)
MC2	Motor control, motor 2 (supply air)
LS ¹⁾	Closing damper, outdoor air/exhaust air
M1	Fan motor 1
M2	Fan motor 2
DRHX	Control unit for the rotary heat exchanger
P1.1X	Measurement point, pressure drop across extract air filter
P1.1Y	Measurement point, pressure drop across extract air filter
P1.2X	Measurement point, airflow in exhaust air
P1.2Y	Measurement point, airflow in exhaust air
P2.1X	Measurement point, pressure drop across outdoor air filter
P2.1Y	Measurement point, pressure drop across outdoor air filter
P2.2X	Measurement point, airflow in supply air
P2.2Y	Measurement point, airflow in supply air

1.3 Application

Comfort ventilation EXHAUSTO VEX is used for comfort ventilation tasks. Operating temperature range for the unit – see section "Technical data".

Prohibited uses The VEX unit is not to be used to transport solid particles or in areas where there is a risk of explosive gases.

1.4 Location requirements

Positioning The air handling unit is designed for indoor fitting. The air handling unit can be ordered for outdoor installation (accessory Outdoor, OD).

1.4.1 Spatial requirements

The drawing below indicates how much space is needed for servicing, replacing filters, cleaning, etc.

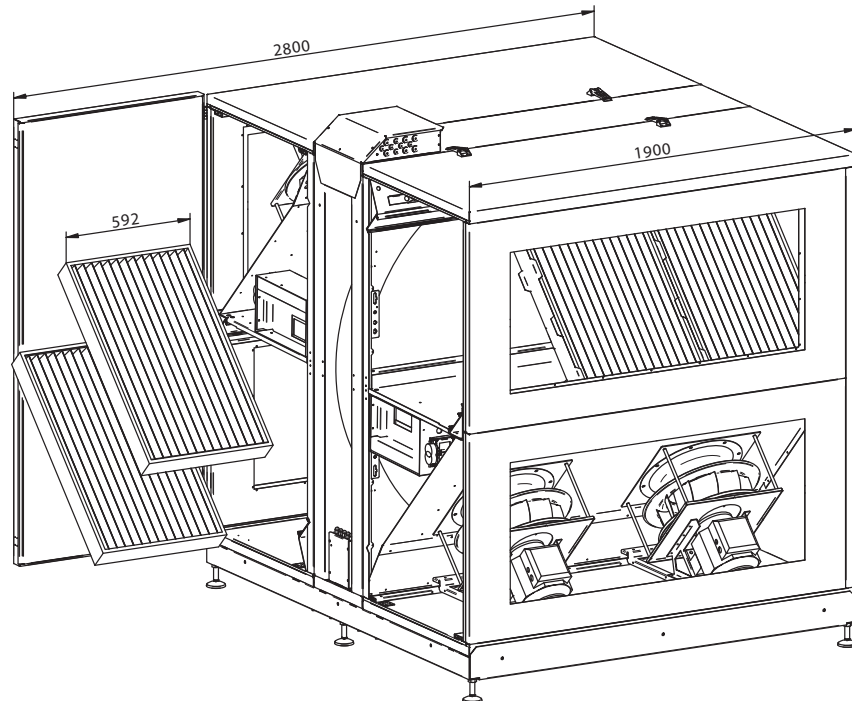

RD12186-02

NB: A free height of at least 200 mm is required above the unit's connection box.

1.4.2 Requirements for underlying surface

When fitting the unit directly, the surface must be:

- flat
- level
- hard
- resistant to vibration

1.4.3 Requirements for duct system

Silencers

The duct system must be fitted with silencers specified by the Project Manager, which meet the requirements of the operating area.

Bends

A duct bend may be fitted immediately after the unit, because the airflow in the spigot has a uniformly moderate speed profile, which results in negligible system pressure loss.

Insulation



The duct system must be insulated against:

- condensation
- sound leakage
- heating/cooling losses

Condensation

Condensation in the ducts may occur when the exhaust/outdoor air has high humidity. EXHAUSTO recommends a condensation outlet is also fitted at the lowest point in the ducts.

No duct connection



If one or more of the spigots is not connected to a duct: Fit a protective net to the spigots with a maximum mesh width of 20 mm.

1.5 Description

1.5.1 The VEX unit design

VEX200L-V1

The drawing below illustrates the construction of the unit (without service doors).

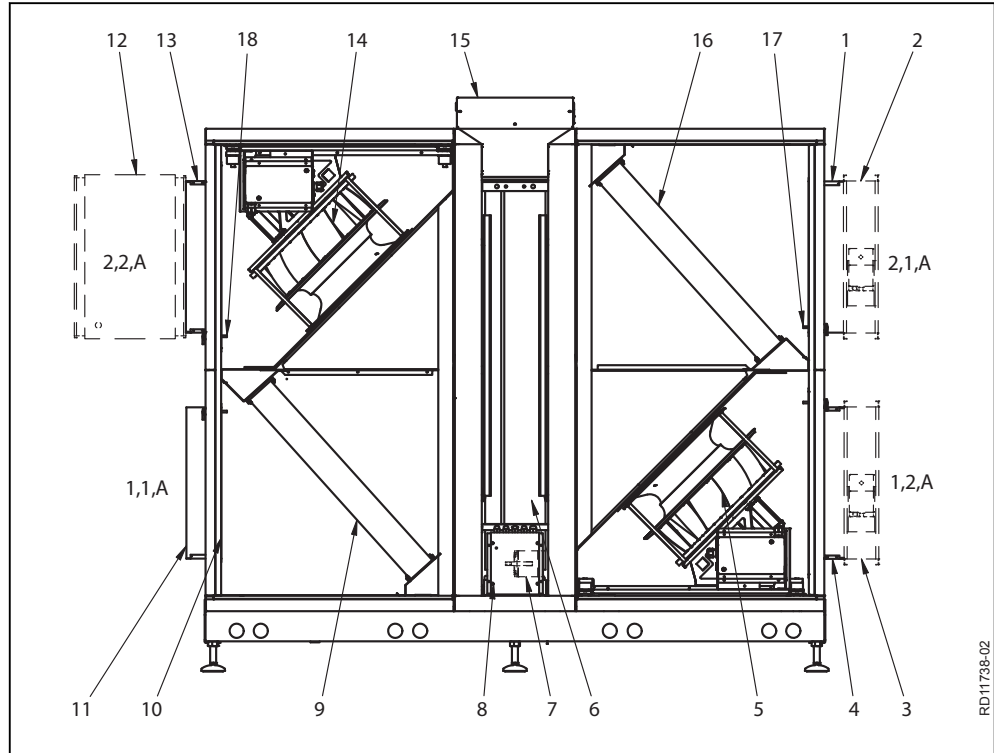

VEX200L-V2

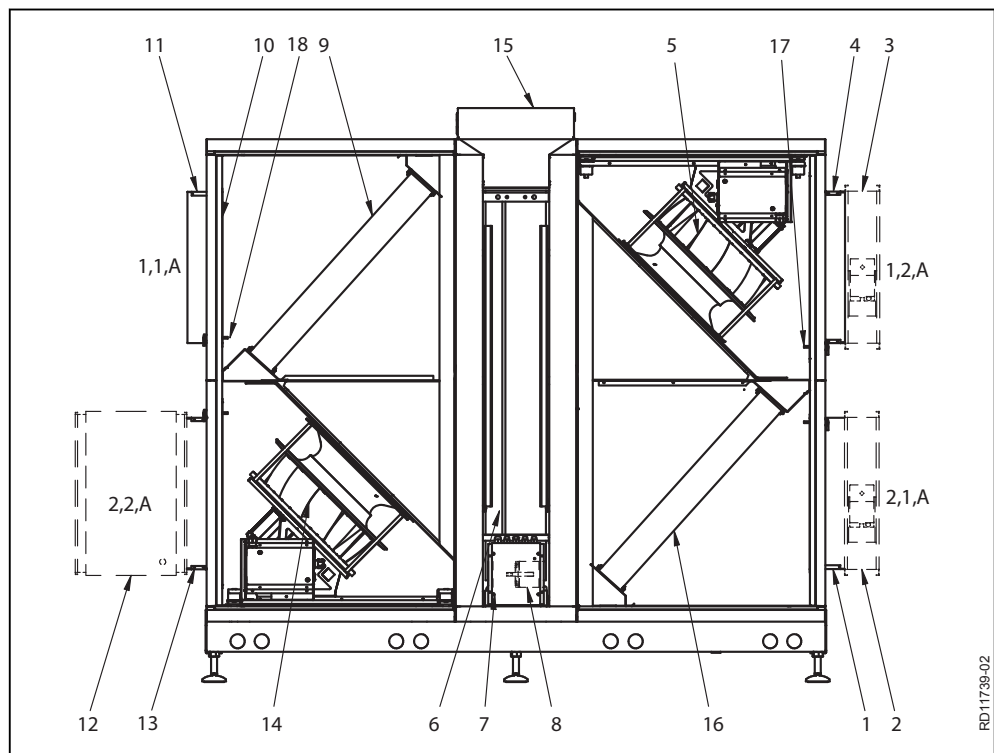

VEX200R-V1

The drawing below illustrates the construction of the unit (without service doors).

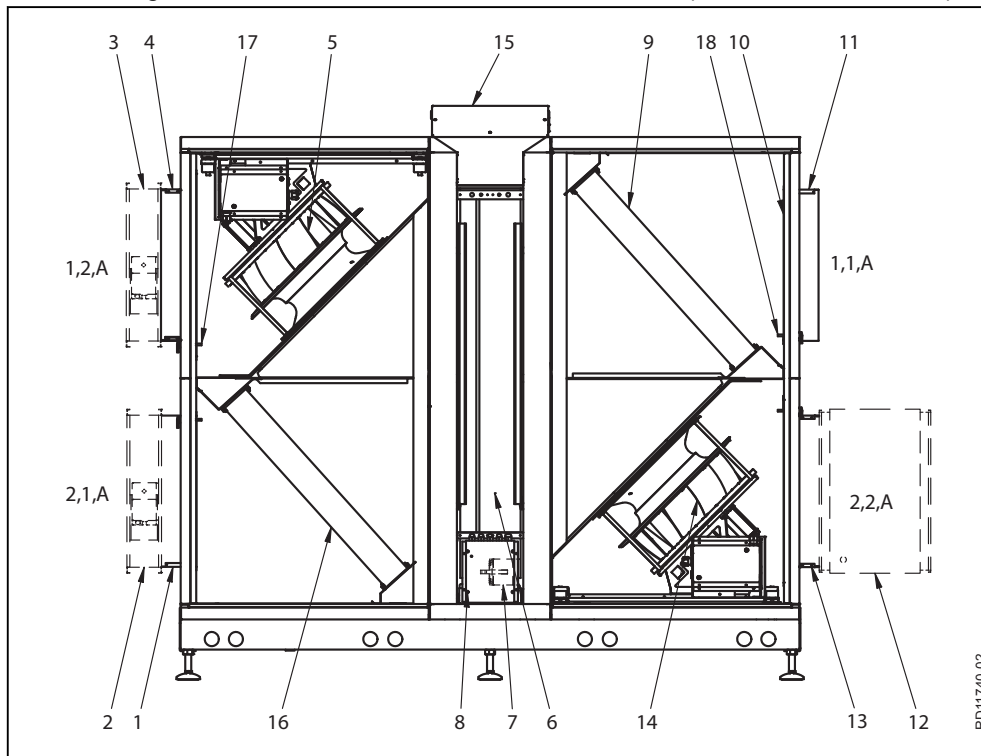

VEX200R-V2

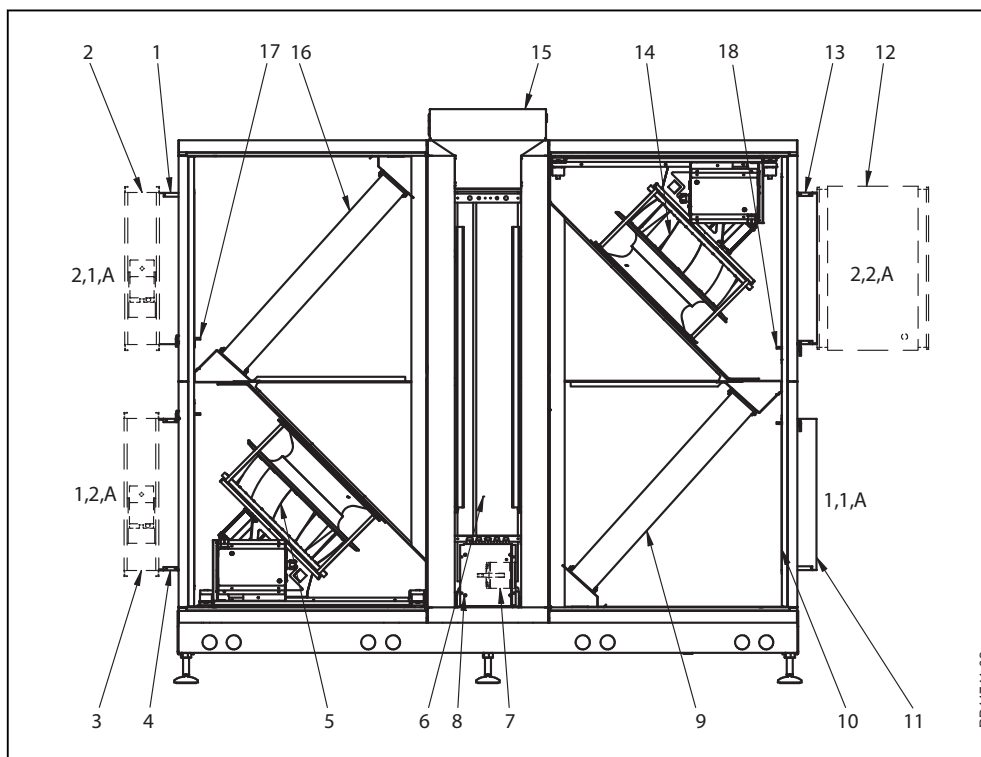

Pos. no.	Part	Function
1	Spigot 2.1.A	Outdoor air spigot The spigot can also be positioned on the top or in the bottom of the unit (2.1.B) – however, only on units with compact filters.
2	Closing damper LS	Closing damper, outdoor air, LSF (accessory).

Pos. no.	Part	Function
3	Closing damper LS	Closing damper, exhaust air, LSA (accessory).
4	Spigot 1.2.A	Exhaust air spigot The spigot can also be positioned on the top of the unit (1.2.B).
5	Fan unit	For extract air/exhaust air
6	Rotary heat exchanger	Conducts heat from extract air to supply air.
7	Step motor	Drives the rotary heat exchanger via the drive belt.
8	Rotor control	Controls and monitors the step motor.
9	Extract air filter	Filters extract air.
10	Trim damper	The trim damper (accessory) ensures there is pressure balance across the rotor and seals to prevent extract air from entering the supply air. Used with purging sector (accessory).
11	Spigot 1.1.A	Extract air spigot The spigot can also be positioned in the bottom of the unit (1.1.B) – however, only on units with compact filters.
12	Heating coil	Heats supply air if heat recovery is insufficient (accessory).
13	Spigot 2.2.A	Supply air spigot. The spigot can also be positioned at the bottom of the air handling unit (2.2.B).
14	Fan unit	For outdoor air/supply air.
15	Connection box	Connection box to fan motor and rotor control.
16	Outdoor air filter	Filters outdoor air.
17	Measurement socket	Measurement socket for pressure loss across the filters.
18	Measurement socket	Measurement socket for airflow calculation.

Cabinet

The inside and outside of the cabinet is made of Aluzinc® and insulated with 50 mm mineral wool.

Ventilators

The unit has two centrifugal fans in the extract air duct and two centrifugal fans in the supply air duct.

Rotary heat exchanger

The rotary heat exchanger is driven by a step motor with rotor control, which controls the rotor's speed.

Filters

There are built-in compact filters (as shown on the drawings on the previous pages) or bag filters on both the extract air and supply air side.

1.6 Principal dimensions

VEX280, V1

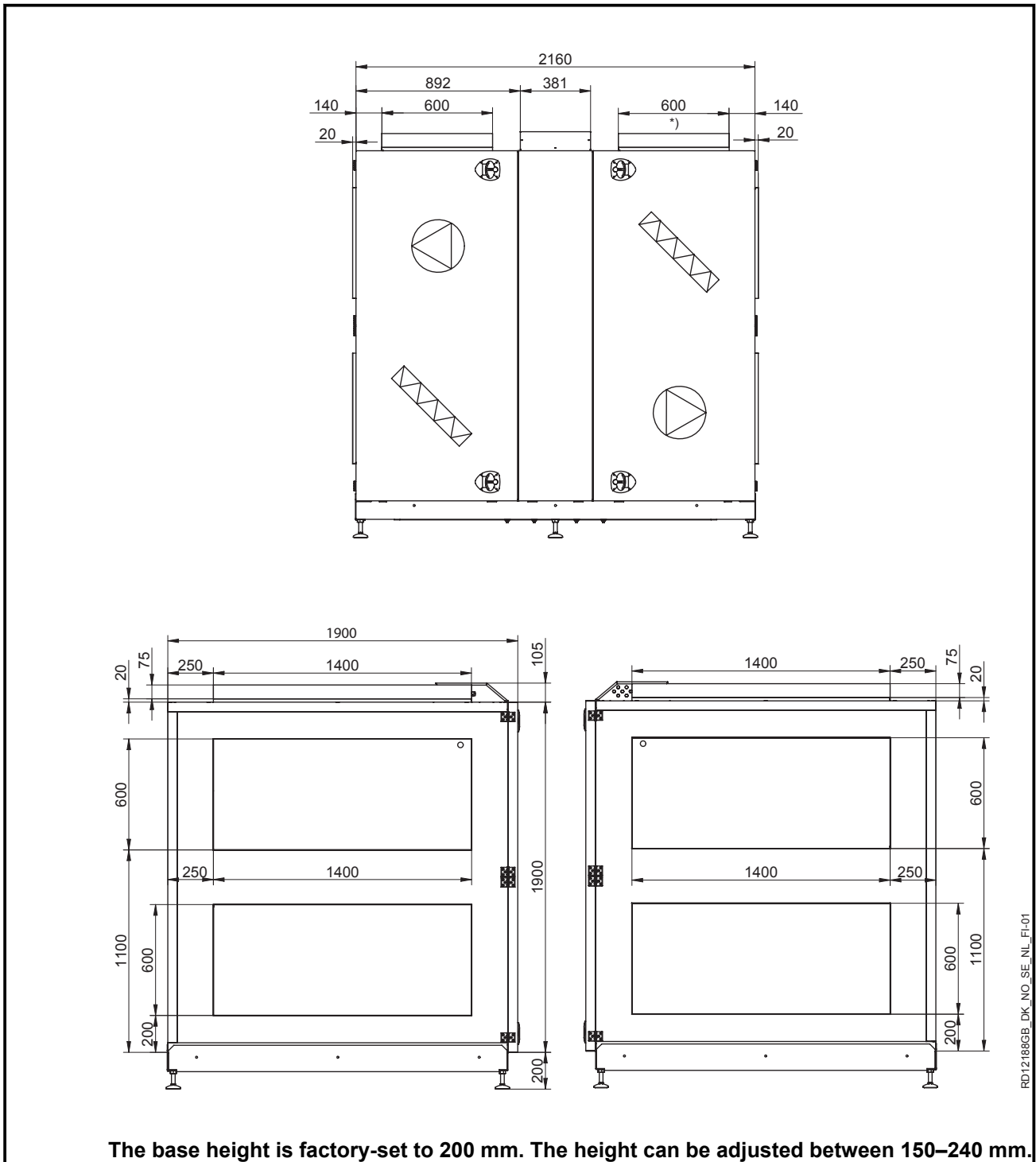

RD12188GB_DK_NO_SE_NL_FF-01

NB

The drawing shows all of the spigot positioning options. Spigot positioning marked with * is not available for VEX units with a bag filter.

VEX280, V2

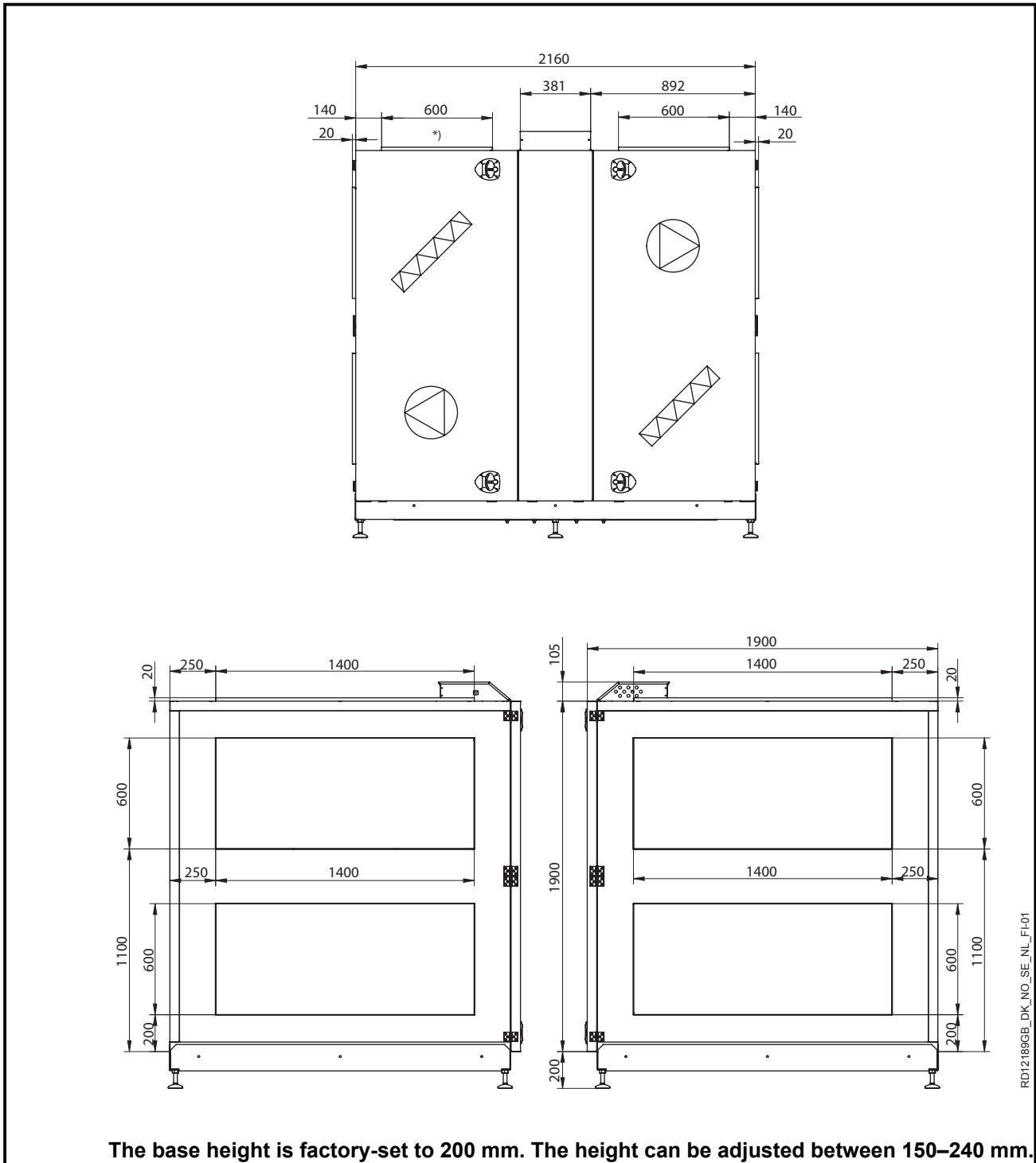

RD12189GB_DK_NO_SE_INL_FI-01

NB

The drawing shows all of the spigot positioning options. Spigot positioning marked with * is not available for VEX units with a bag filter.



2. Handling

2.1 Unpacking

Supplied components

The following components are supplied:

- VEX unit
- Supplied with accessories (as indicated in the checklist on the front page of the instructions)

Packaging

The unit is delivered attached to a disposable pallet and packed in clear plastic.

NB

Once the plastic has been removed, the unit must be protected against dirt and dust:

- **The covers on the spigots must not be removed until the spigots are connected to the ventilation ducts.**
- **Whenever possible, keep the unit closed during fitting.**

The unit should be cleaned before it is used.

Once the VEX unit is fitted, it must be checked and thoroughly cleaned. All dust, debris and metal shavings must be vacuumed up.

2.2 Transport

2.2.1 Weight

The unit weighs: 1,054 kg.

Transport equipment

See the supplementary instructions "3003200, Transport of VEX280" for the transport and handling of the VEX.

2.2.2 The VEX sections' principal dimensions

Measurements are based on the exact dimensions of the VEX unit.

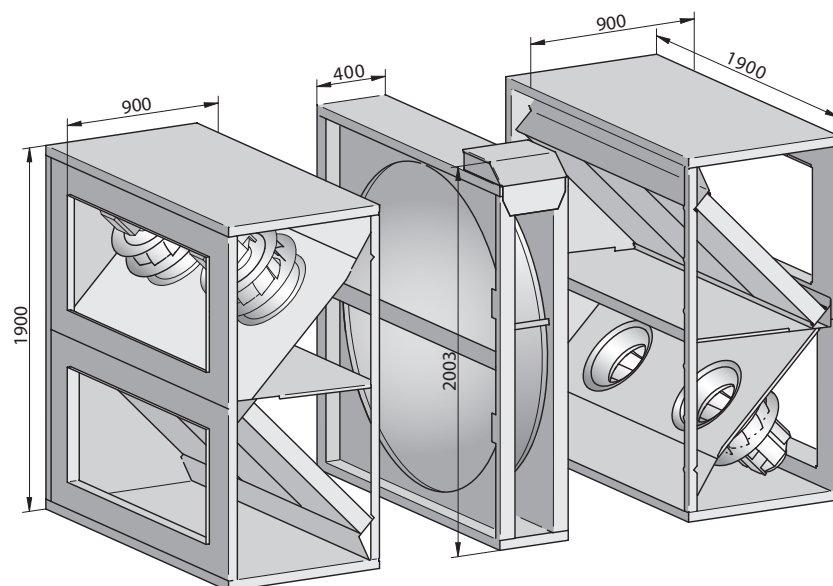

RD12190-01

2.2.3 Internal transport with reduced weight

Weight reduction The weight can be reduced during transport by removing the service doors and fan units.

Removing the service doors To remove the service doors:

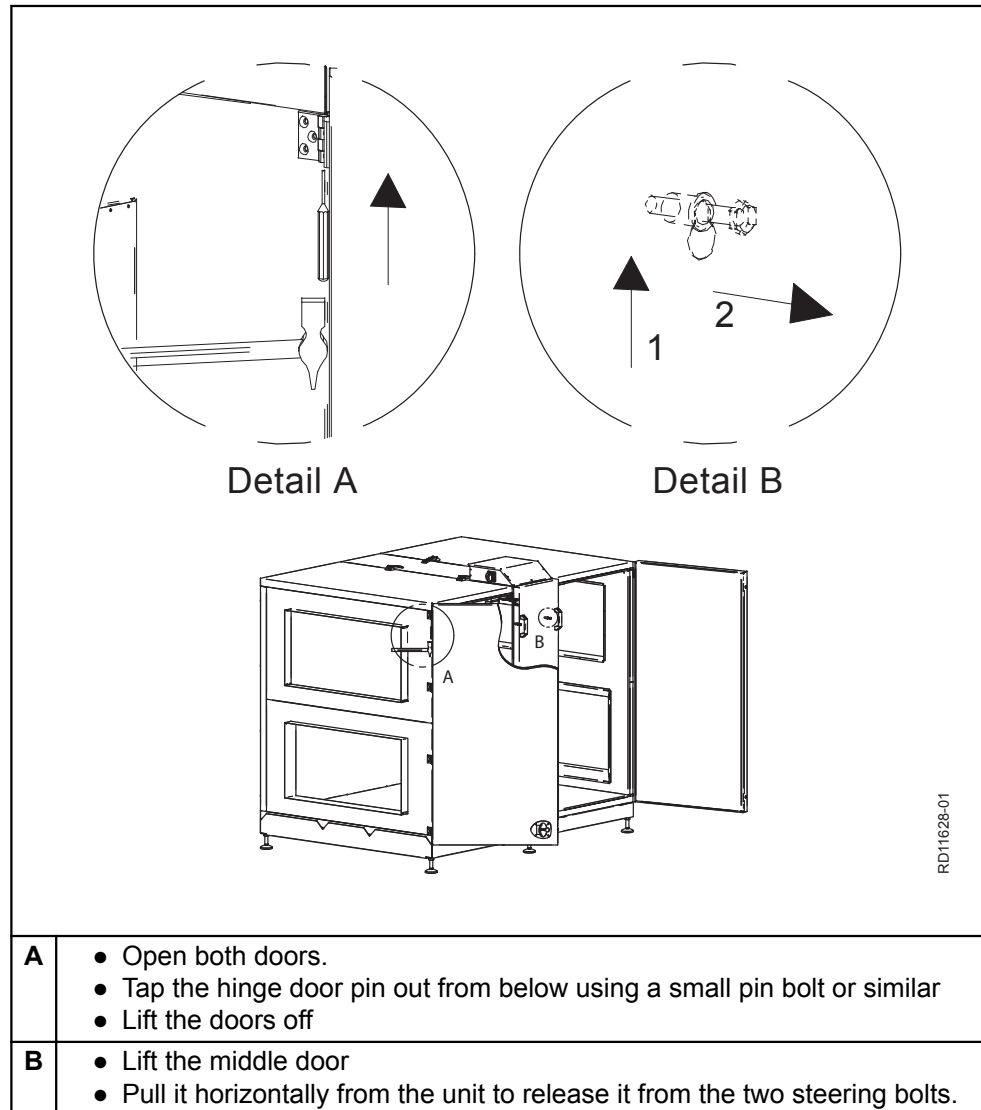

To remove the fan unit

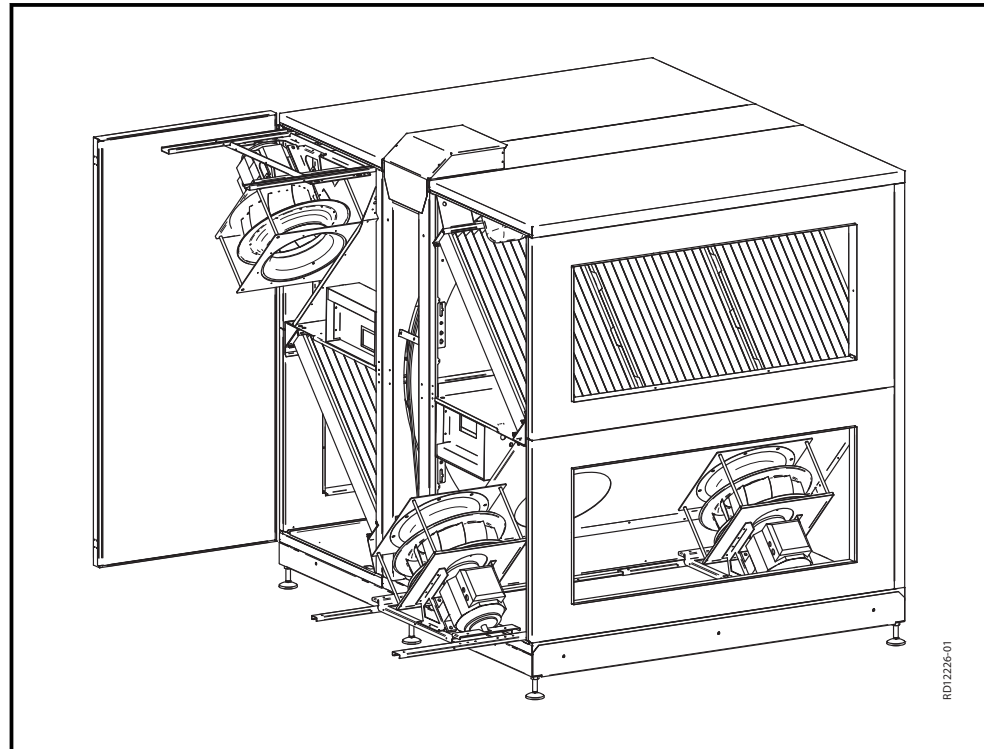

Step	Action
1	Remove the fixing screws on the sliding rails (out towards the operating side)
2	Loosen the bindings on the motor cable and the measuring hose (on the outermost motor)
3	Pull the fan unit out to the end-stop (a screw on each rail acts as a stop)
4	Remove the supply cable and modbus cable in the motor control box
5	Remove the measuring hose that is fixed to the intake on the outermost motor
6	Remove the two end-stop screws (one on each rail). The fan unit can now be lifted NB: The fan units weigh: <ul style="list-style-type: none"> • VEX280: 40 kg each If the innermost motor also has to be removed, repeat the procedure from step 2



3. Mechanical assembly

3.1 Installing the unit

3.1.1 Assembly instructions

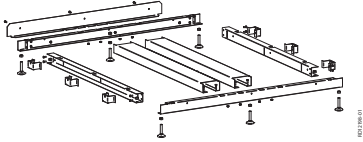
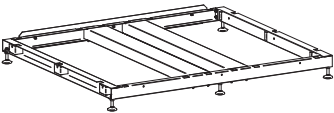
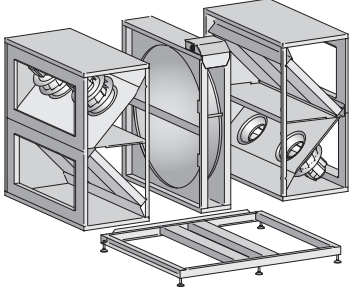
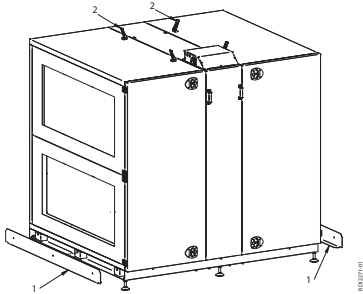
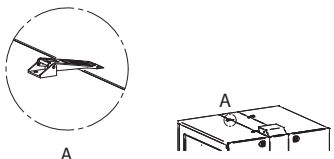
Step 1	Step 2	Step 3
		
Step 4	Step 5	
		

Step 1-2, Base

- Assemble the base

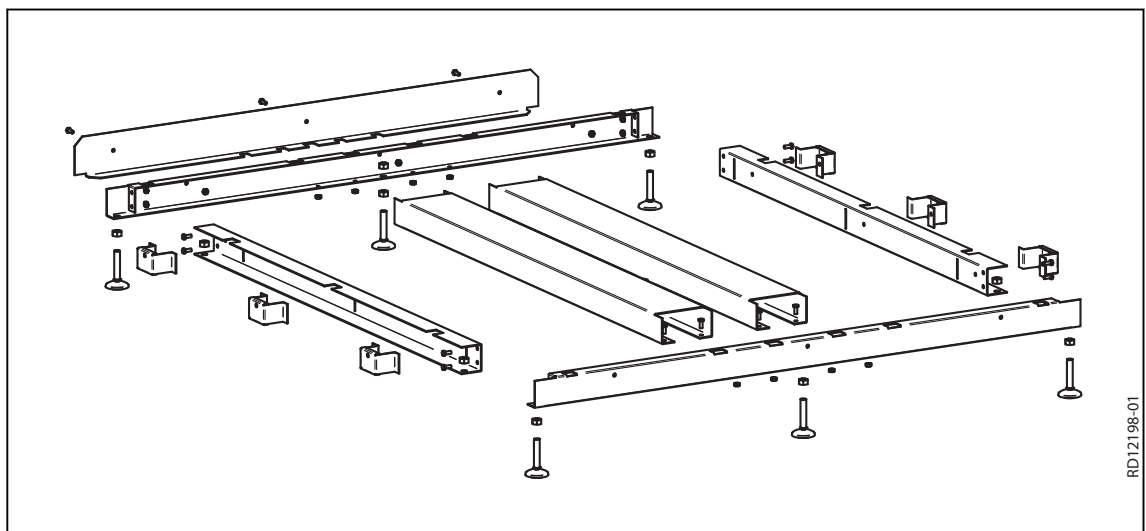

It is important that the base is level before the VEX unit is placed on it. Adjust the levelling screws, so that the base is horizontal (+/- 20 mm per metre)

Diagram showing
levelling screw po-
sitions

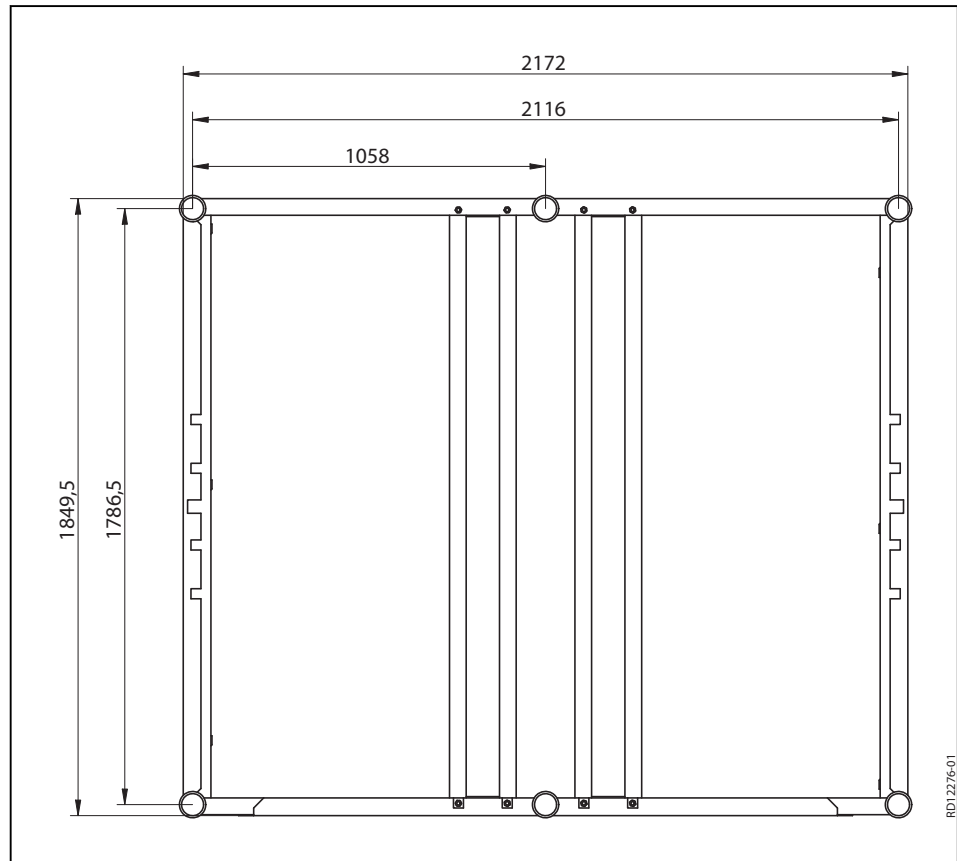

- The base must be level before installing the VEX.

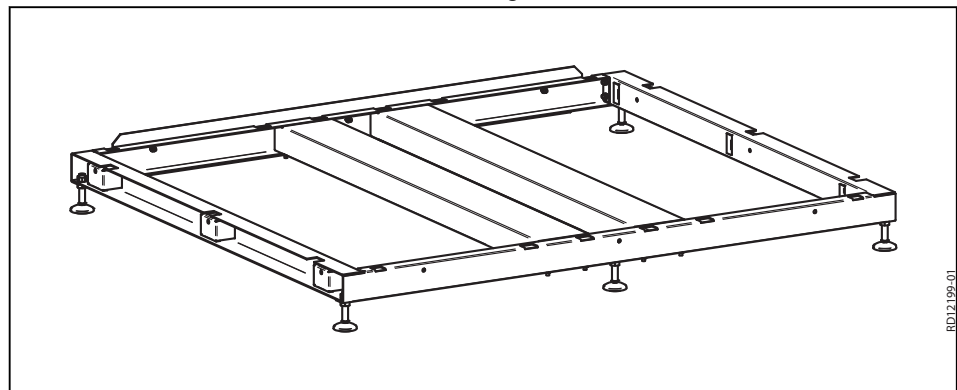

Step 3, VEX sections

- Set the ventilator section up first. The sections can be moved directly from the pallet onto the base.

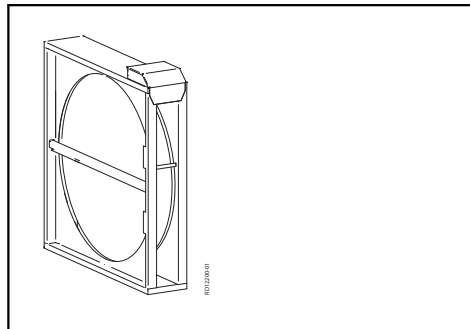
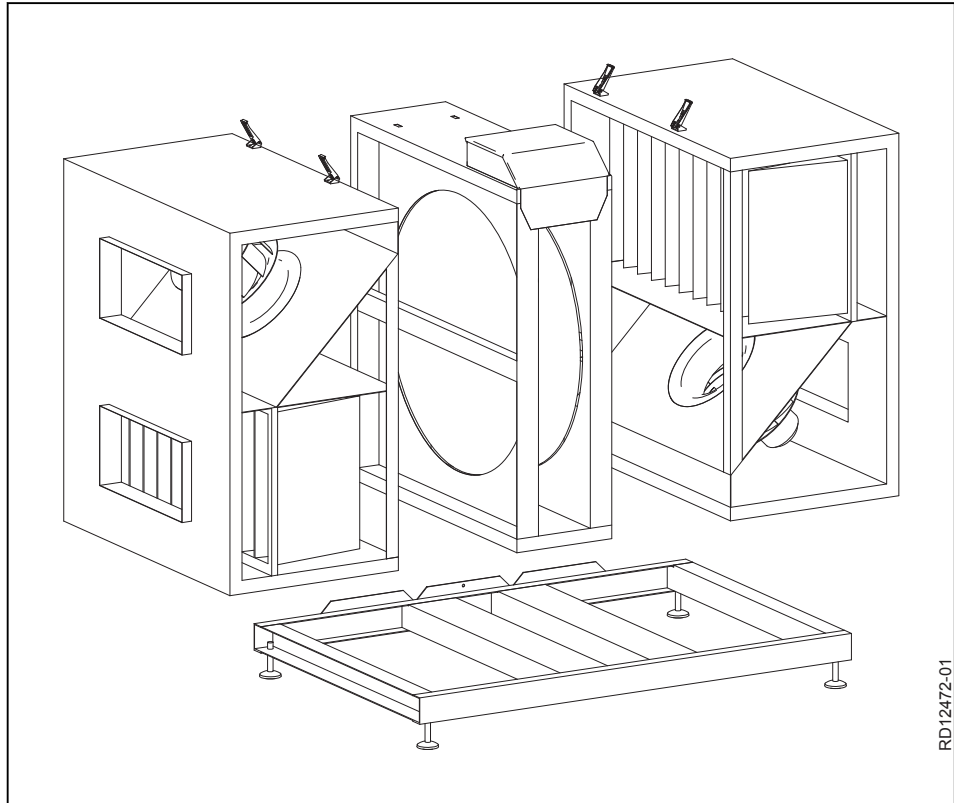

The rotor section must be handled with care. It should never be left to stand unsupported, as it may tip over.

Step 4, Assemble the panels

- Removing the assembled base sides (1)
- When all three sections are on the base, tighten both sides in to the VEX (after all three sections are on the base)

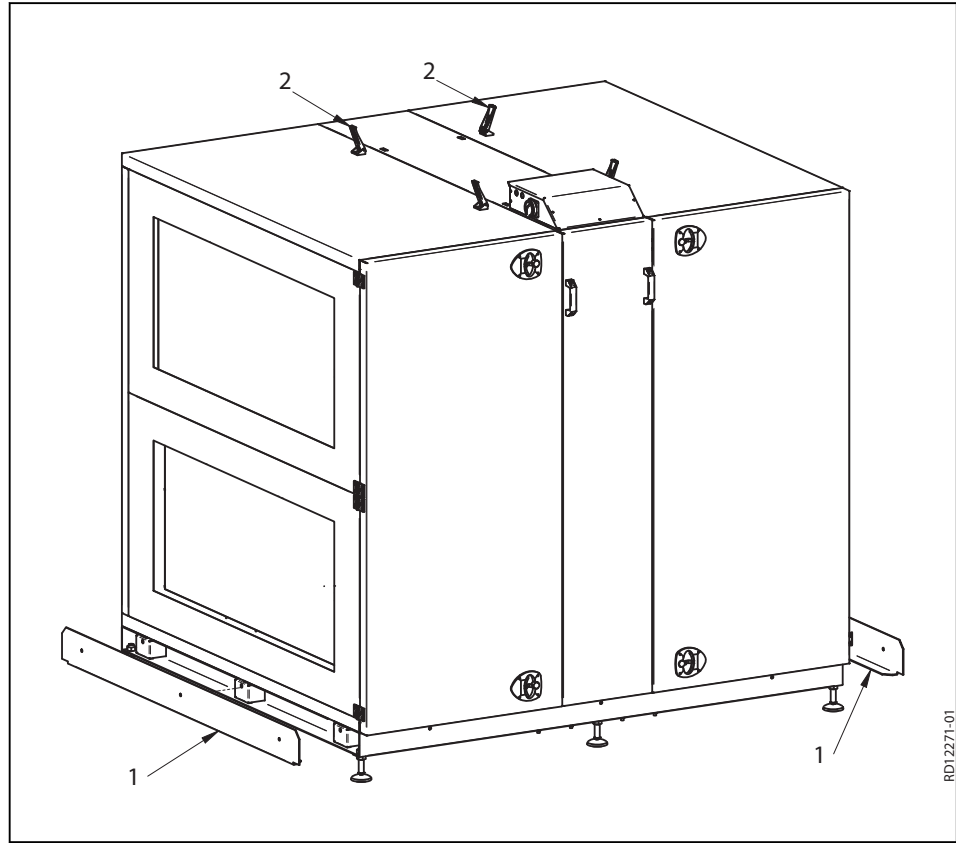

Step 5, Top fixtures

- Open the four fittings (2) on the top of the VEX.

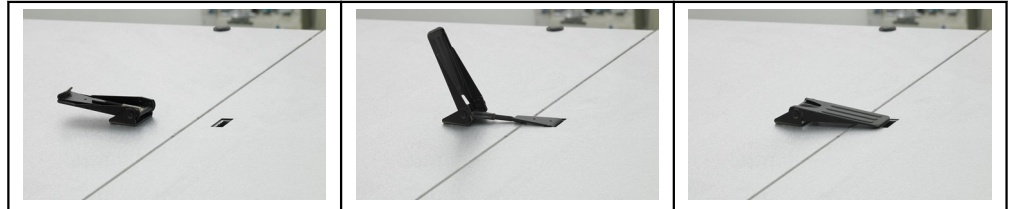



4. Electrical installation

4.1 Electrical installation

See the attached instructions "Guide to Electrical Installation of VEX260/270/280 for third party control systems":

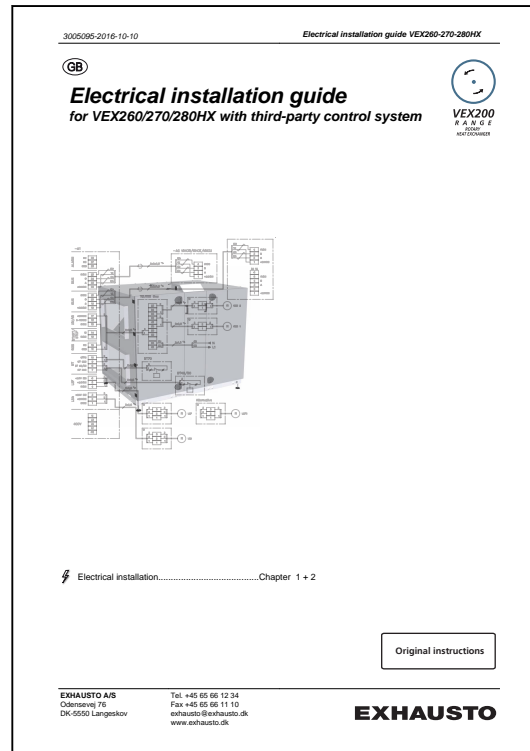



5. Maintenance

5.1 Maintenance chart

Recommended intervals The following chart details the recommended maintenance intervals, under normal operating conditions. EXHAUSTO recommends maintenance is adjusted to suit the actual operating requirements.

Component	Procedure	Once a year	Twice a year
Filters*	Recommended that both filters are replaced at the same time. Filters should be replaced at least:		X
Filter monitor	Check that all the seals in the filter monitor are tight.	X	
Seals and sealing strips	Check that all the seals are tight.	X	
Fans and heating coil (accessories)	Check Removal of fan unit. See section "Internal transport with reduced weight" Cleaning. See next section	X	
Rotary heat exchanger	Check Clean when required. See next section.	X	

*Filters



Only use original filters

- The provided filter data and pressure loss graphs (section "Technical data") are based on the use of original filters
- EUROVENT certification is only valid if original filters are used
- Use of non-original filters may cause leakage in the VEX and impair filter function
- EXHAUSTO recommends that you register the filter replacement date to ensure filters are replaced at the correct intervals

5.2 Service

5.2.1 Filter change

Use original filters



Only use original filters. See section "Maintenance chart".



Disconnect power at the isolation switch before opening the door.

Pull the filters out. Remember to check the flow direction - see the arrows on the filter.
Discarded filters must be stored immediately in sealed plastic bags and disposed of responsibly.

5.2.2 Servicing and cleaning



Cleaning motor/fan See section "Internal transport with reduced weight" for details on how to remove the fan units.

Step	Action
1	Switch off the power supply to the unit at the isolation switch before opening the doors
2	Clean the fan impellers with a vacuum cleaner and wipe down with a damp cloth if necessary
3	Clean the impeller blades carefully, so as not to disturb the balance
4	Once re-fitted, check the unit operates without vibrating
Inspection of measuring points hoses	
5	Remove the hoses at the connection box
6	Blow air through the hoses to remove any impurities

Cleaning cold water coil/heating coil

Step	Action
1	Switch off the power supply to the unit at the isolation switch
2	Vacuum clean the cold water coil/heating coil
3	Cold water coil: clean the condensation tray
4	Check the fins on the exchanger are not deformed.  The fins are sharp.

Cleaning rotary exchanger

Step	Action
1	Switch off the power supply to the unit at the isolation switch before opening the doors
2	Vacuum clean the exchanger with caution, ideally using a soft brush vacuum nozzle.  Avoid touching the fins in the exchanger with sharp or hard objects – the fins are very soft and can easily be deformed, which will diminish the performance of the VEX.
3	Check the fins on the exchanger are not deformed.  The fins are sharp.

5.3 Airflow measurement

5.3.1 Determining airflow and pressure

Use the formulae in the table to calculate airflow and pressure drop over the filters.

Airflow:	Airflow q_V (l/s, m ³ /h) can be read from the differential pressure Δp_M [Pa]
Extract air	$\Delta p_{M1.2} = P_{1.2X} - P_{1.2Y}$ [Pa]

Airflow:	Airflow q_V (l/s, m³/h) can be read from the differential pressure Δp_M [Pa]
Supply air	$\Delta p_{M2.2} = P_{2.2X} - P_{2.2Y}$ [Pa]

Pressure drop across:	
Extract air filter	$\Delta p_{1.1} = P_{1.1X} - P_{1.1Y}$ [Pa]
Supply air filter	$\Delta p_{2.1} = P_{2.1X} - P_{2.1Y}$ [Pa]

Location of measurement points

The location of measurement points is shown on the drawing. The exterior measuring points positions on the VEX are shown in the drawings in the section "Description".

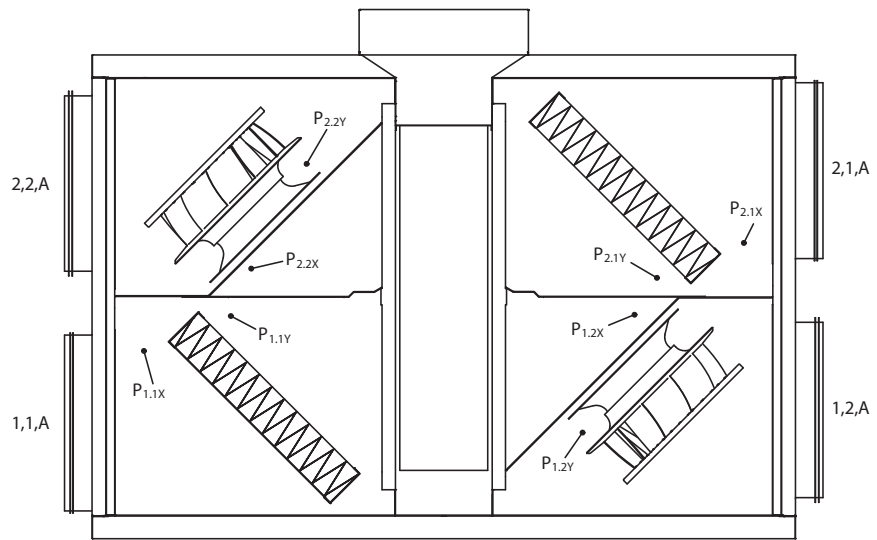

RD13710-01

Supply air

Supply airflow diagram:

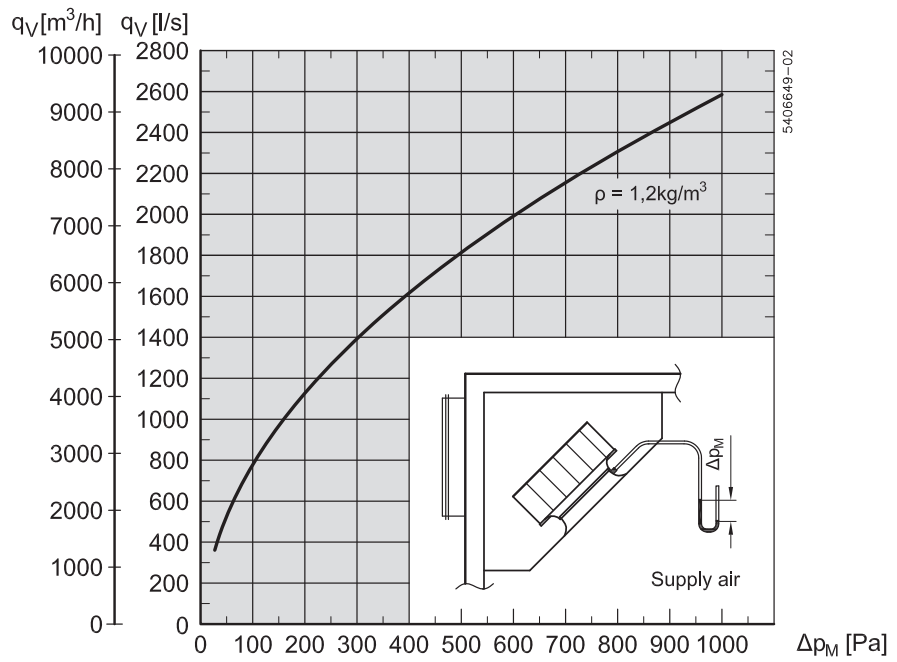

— Airflow (q_v) according to pressure difference (Δp_M)

$$\left. \begin{aligned} q_v &= 483,12 \cdot \sqrt{\frac{2 \cdot \Delta p_M}{\rho}} \text{ [m}^3/\text{h]} \\ q_v &= 134,2 \cdot \sqrt{\frac{2 \cdot \Delta p_M}{\rho}} \text{ [l/s]} \end{aligned} \right\} \pm 10\% \text{ for } \Delta p_M > 40 \text{ Pa}$$

NB! Curve is for one fan.

Extract air

Extract airflow diagram:

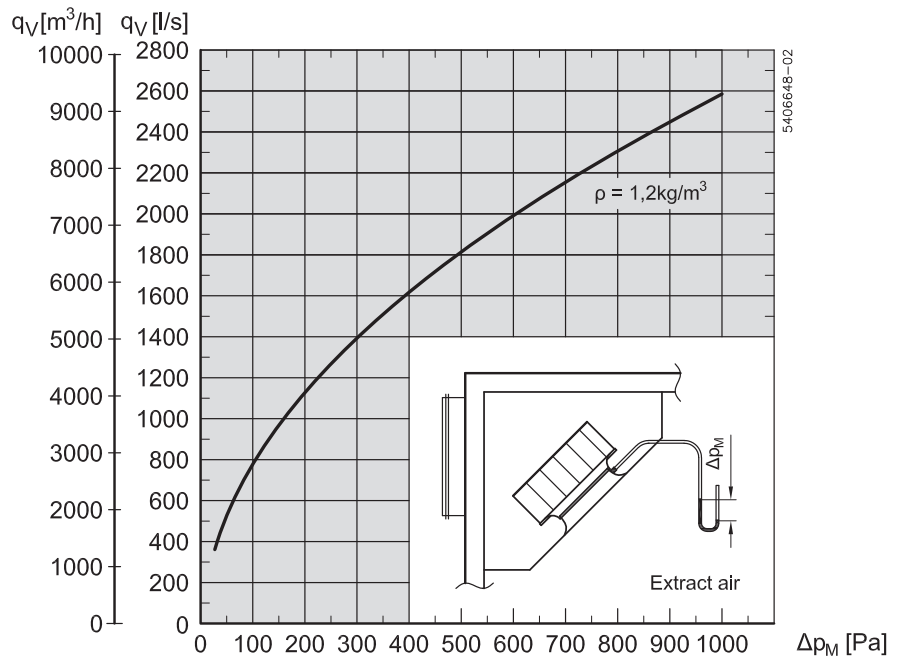

— Airflow (q_V) according to pressure difference (Δp_M)

$$\left. \begin{aligned} q_V &= 483,12 \cdot \sqrt{\frac{2 \cdot \Delta p_M}{\rho}} \text{ [m}^3/\text{h]} \\ q_V &= 134,2 \cdot \sqrt{\frac{2 \cdot \Delta p_M}{\rho}} \text{ [l/s]} \end{aligned} \right\} \pm 10\% \text{ for } \Delta p_M > 40 \text{ Pa}$$

NB! Curve is for one fan.



6. Technical specifications

6.1 Weight, corrosion class, temperature ranges, etc.

Weights

	VEX280
The total weight of the unit	1102 kg
Unit without doors, fan section and base (for internal transport)	
Fan section	2 x 236 kg
Rotor section	221 kg
Doors, fan section	2 x 28 kg
Door, rotor section	14 kg
Base	115 kg
Fan unit	4 x 40 kg

Corrosion class

Corrosion class	Corrosion class C4 in accordance with EN ISO 12944-2
-----------------	--

Temperature range

Outdoor air temperature	-40°C to +35°C
Ambient temperature	-30°C to +50°C

At temperatures below -25°C (with outdoor installation), use of a thermostatically controlled heater in automated control box is recommended.

Motor data

Voltage	3 x 400 V/3 x 230 V
Max. rpm	2900 rpm
Torque	13.5 Nm
Motor class in accordance with IEC TS 60034-30-2	IE5 (Ultra Premium efficiency)

6.2 Compact filters

Pressure loss curves for M5 and F7 filters

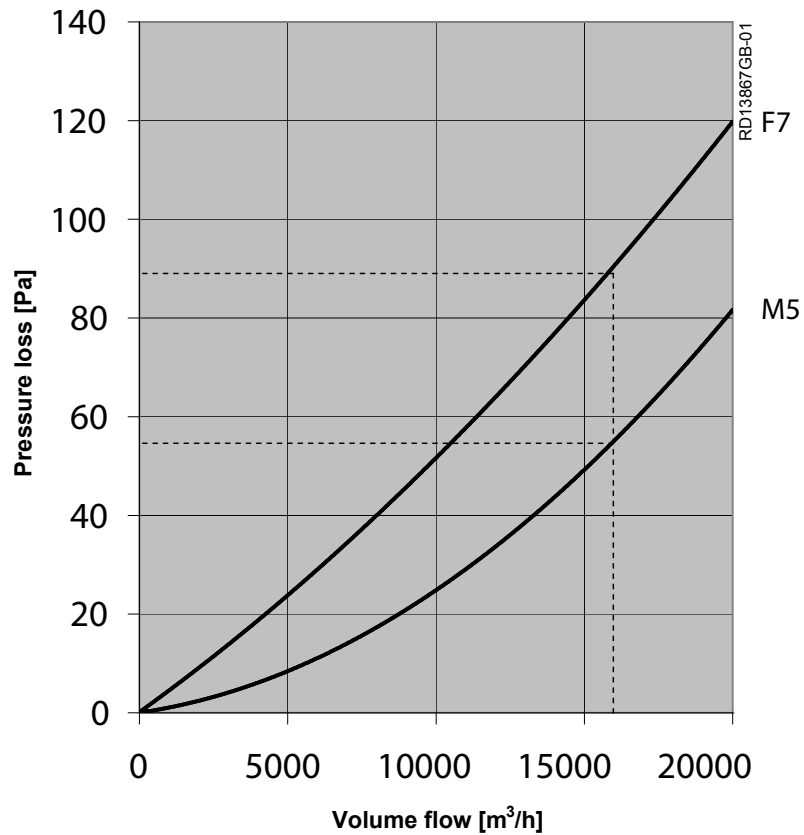

Filter data	VEX280	
	FP280F5	FP280F7
Panel filter h x w	qty. 3 980 x 592 mm	
Panel filter thickness	96 mm	
Filter area	3 x 6.7 m ²	3 x 20.9 m ²
Filter class	M5	F7
Retention efficiency in accordance with EN779	96 %	> 99 %
Efficiency	45 %	85 %
Volume flow rate	16,000 m ³ /h	
Initial pressure drop	55 Pa	89 Pa
Recommended final pressure drop at normal volume flow rate	155 Pa	189 Pa
Temperature resistant to	70°C	



EUROVENT certification is only valid if original filters are used. For more details about original filters, see section "Maintenance".

6.3 Bag filters

Pressure loss curves for M5 and F7 filters

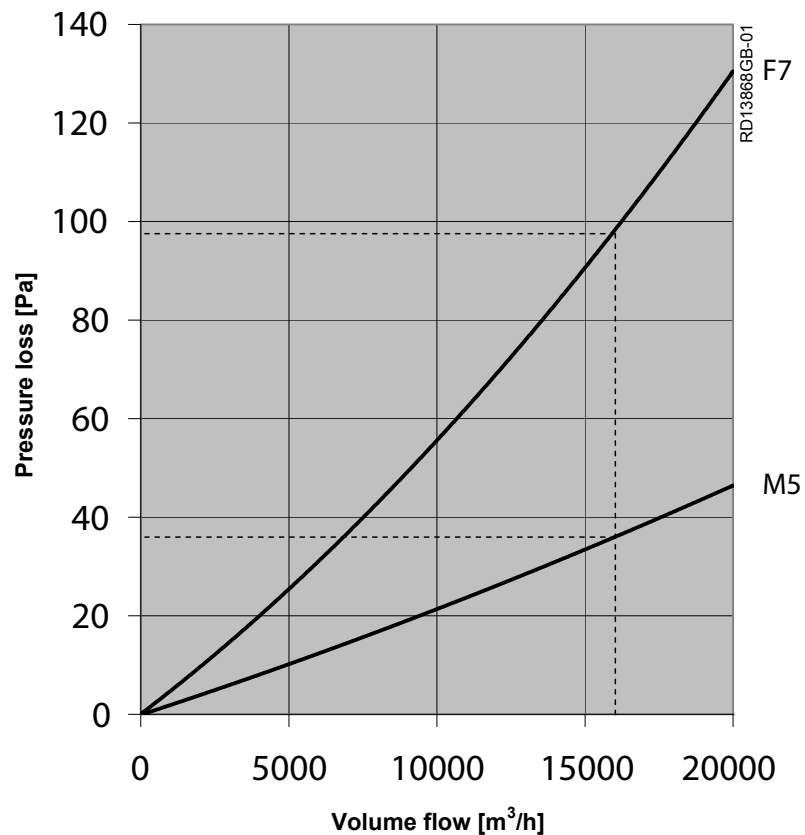

Filter data	VEX280	
	FB280M5	FB280F7
Filter area	3 x 6.9 m ²	3 x 9.9 m ²
Face area h x b	qty. 3 892 x 592 mm	
Total number bags x depth	qty. 3 6 x 600 mm	qty. 3 10 x 535 mm
Filter class	M5	F7
Retention efficiency in accordance with EN779	96 %	> 99 %
Efficiency	45 %	85 %
Volume flow rate	16,000 m ³ /h	
Initial pressure drop	36 Pa	98 Pa
Recommended final pressure drop at normal volume flow rate	136 Pa	198 Pa
Temperature resistant to	70°C	



EUROVENT certification is only valid if original filters are used. For more details about original filters, see section "Maintenance".

6.4 Capacity diagrams

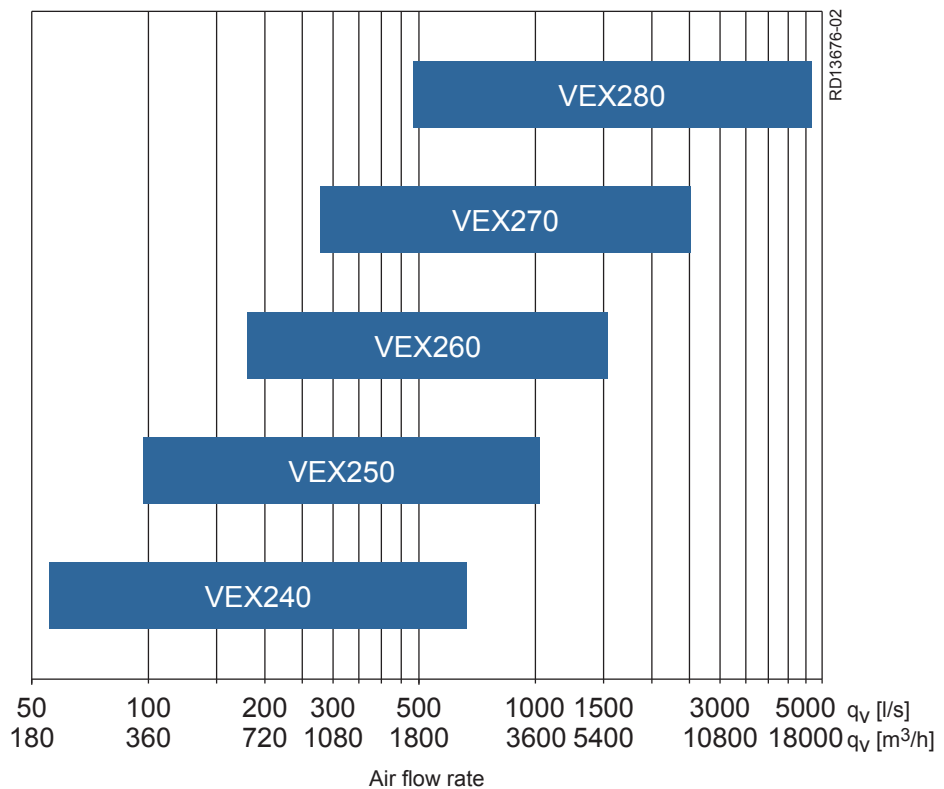

Recommendation



You are recommended to make a more precise calculation of the unit's capacity with the EXselect calculation program, available on the EXHAUSTO website.

6.5 Ordering spare parts

Find production number

When ordering spares, please state the relevant production part number. This will ensure that the correct parts are delivered. The production number is given on the front of the VEX guidelines and on the VEX rating plate.

Contact:

Contact your local EXHAUSTO office service department to order a spare part. Contact information is given on the back cover of these instructions. See also the "Layout" section for an overview of the position and designation of parts in the VEX.



Scan code and go to addresses at
www.exhausto.com