

GB

VEX330H w/ EXact control system

Installation instructions



Unit supplied with (factory fitted):





- VEX330H, motor type 1
- VEX330H, motor type 2
- AFC
- MPTF
- DEP
- Compact filter M5
- Compact filter F7
- OD - roof for outdoor

The following accessories are supplied separately:

- pieces, HMI control panel
- HCW external heating coil (water)
- HCE external heating coil (electrical)
- Closing damper, LS315-24, (LSF outdoor)
- Closing damper, LS315-24, (LSA exhaust)
- Closing damper, LSR315-24, with spring-return (LSFR outdoor)
- pieces, MIO-PIR motion sensor
- pieces, MPTDUCT constant pressure control
- MIO-RH humidity sensor
- MIO-CO2-ROOM, CO₂-sensor
- MIO-CO2-DUCT, CO₂-sensor
- MIO-TS-DUCT temperature sensor
- MIO-TS-ROOM , temperature sensor
- MXCU control for external cooling unit
- _____

Prod.order no.: _____

Sales order no.: _____

-  Product information.....Chapter 1 + 6
-  Mechanical assembly.....Chapter 2 + 3
-  Electrical installation.....Chapter 4
-  Maintenance.....Chapter 5

Original instructions



1. Product information

1.1. Terms used in these instructions	6
1.1.1. Simplified diagram.....	6
1.2. Application	6
1.3. Location requirements	7
1.3.1. Space requirements.....	7
1.3.2. Requirements for underlying surface.....	7
Condensation outlet.....	7
1.3.4. Requirements for duct system.....	8
1.4. Description	9
1.4.1. Construction of the VEX unit.....	9
1.4.2. Parts of the VEX unit.....	10
1.5. Principal dimensions	10
1.5.1. Dimensioned sketch.....	10



2. Handling

2.1. Unpacking	11
2.1.1. Weight.....	11
2.2. Transport	11
2.2.1. Passage through openings.....	12
2.2.2. Internal transport with reduced weight.....	13



3. Mechanical assembly

3.1. Positioning of unit	14
Installation directly on floor.....	14
3.1.2. Subsequent installation of base.....	14
3.2. Condensation drain	14
3.2.1. Establishment of condensation outlet.....	15



4. Electrical installation

4.1. Electrical installation	16
---	-----------



5. Maintenance, hygiene and servicing

5.1. Operating readings via the HMI panel	17
5.2. Maintenance	17
5.2.1. Opening the VEX unit.....	17
5.2.2. Overview of maintenance intervals.....	18
5.3. Hygiene	18
5.4. Servicing and cleaning	18
5.4.1. Filter change.....	18
Servicing and cleaning the motor.....	19
5.4.3. Cleaning the condensation tray.....	21
5.4.4. Removing and cleaning the counter flow heat exchangers.....	21
5.4.5. Cleaning the heating coils.....	23



6. Technical data

6.1. Weight, corrosion class, temperature ranges, etc	24
6.2. Compact filters	26
6.3. Capacity diagram	27

6.3.1. Capacity diagram, VEX330H-1.....	27
6.3.2. Capacity diagram, VEX330H-2.....	28
6.4. EC Declaration of Conformity.....	28
6.5. Ordering spare parts.....	28

Symbols, terms and warnings

Prohibition symbol



Failure to observe instructions marked with a prohibition symbol may result in serious or fatal injury.

Danger symbol



Failure to observe instructions marked with a danger symbol may result in personal injury and/or damage to the unit.

Scope

This instruction manual is for use with EXHAUSTO VEX-type air handling units. Please refer to the product instructions regarding accessories and extra equipment.

The instructions must be fully observed to ensure personal safety and to protect the equipment and ensure its correct operation. EXHAUSTO A/S accepts no liability for accidents caused by equipment not used in accordance with the manual's instructions and recommendations.

Opening...



Do not remove the detachable panel until the supply voltage has been disconnected at the isolation switch (arrow) and the fans have stopped.

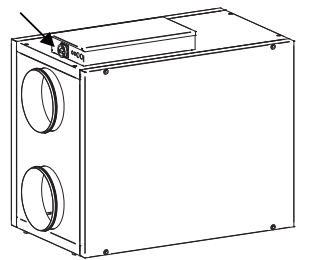

Do not remove both panels at the same time, as the cabinet becomes unstable.

Prohibited uses



The VEX unit is not to be used to transport solid particles or in areas where there is a risk of explosive gases.

No duct connection



If one or more of the spigots is not connected to a duct: fit a protective net to the spigots with a maximum mesh width of 20 mm.

Information plate

The VEX unit information plate shows:

- VEX model type (1)
- Unit production order no. (2)

EXHAUSTO A/S		CE	
Type	V320CREC1	← 1	← 2
	No./Year 1234567/11		
Supply	Voltage: 2x230V+PE/1x230V+N+PE	Current: 2,6A/2,6A	

NB:

Always have the production number ready when contacting EXHAUSTO A/S.

Supply air/extract air

This instruction manual uses the following terminology:

- Supply air (air blown in)
 - Extract air (air removed)
 - Outdoor air
 - Exhaust air
-

Front page: Accessories

On the front page of the instruction manual is a checklist, detailing the accessories delivered with the VEX unit.

NB:

When retrofitting EXHAUSTO accessories, please update the checklist on the front page.

Left/Right

VEX330H is designed for use as both a Left and Right model, as both side panels can be removed.



1. Product information

1.1 Terms used in these instructions

1.1.1 Simplified diagram

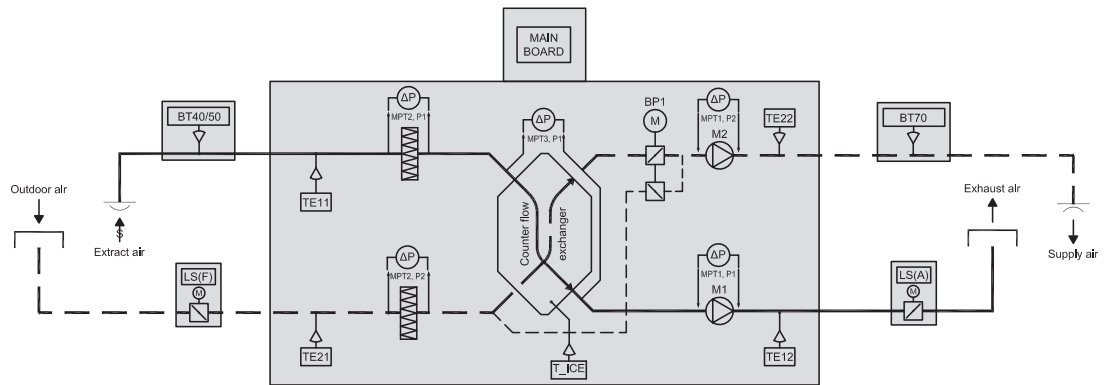

R013087GE-01

Component	Function	Standard/Accessory
BP1	Bypass damper outdoor/supply air	Standard
BT40/BT50	Fire thermostat 40 °C/50 °C (extract air)	Accessory
BT70	Fire thermostat 70 °C (supply air)	Accessory
LS (F)	Closing damper outdoor air	Accessory
LS (A)	Closing damper exhaust air	Accessory
M	Bypass motor	Standard
M1	Extract/exhaust air motor	Standard
M2	Outdoor/supply air motor	Standard
Mainboard	Control panel	Standard
MPT1, P1	Airflow control, extract air	Standard
MPT1, P2	Filter monitor, extract air	Standard
MPT2, P1	Airflow control, supply air	Standard
MPT2, P2	Airflow control, outdoor air	Standard
MPT3, P1	Ice detection	Standard
TE11	Temperatur sensor, extract air	Standard
TE12	Temperature sensor, exhaust air	Standard
TE21	Temperatur sensor, outdoor air	Standard
TE22	Temperature sensor, supply air	Standard
T _{ice}	Temperature sensor for ice in heat exchanger	Standard

1.2 Application

Comfort ventilation

EXHAUSTO VEX is used for comfort ventilation tasks. Operating temperature range for the unit – see section "Technical data".

Prohibited uses

The VEX unit is not to be used to transport solid particles or in areas where there is a risk of explosive gases.

1.3 Location requirements

Positioning

The unit is designed for indoor fitting. The unit may be fitted outdoors if it is fitted with a cover (accessory VEX300HOD).

1.3.1 Space requirements

The cabinet has a detachable panel on each side. The drawing below indicates how much space is needed for servicing the unit, i.e. changing filters, cleaning, servicing, etc. See section "Principal dimensions" for more details.



The cabinet becomes unstable if both detachable panels are removed!

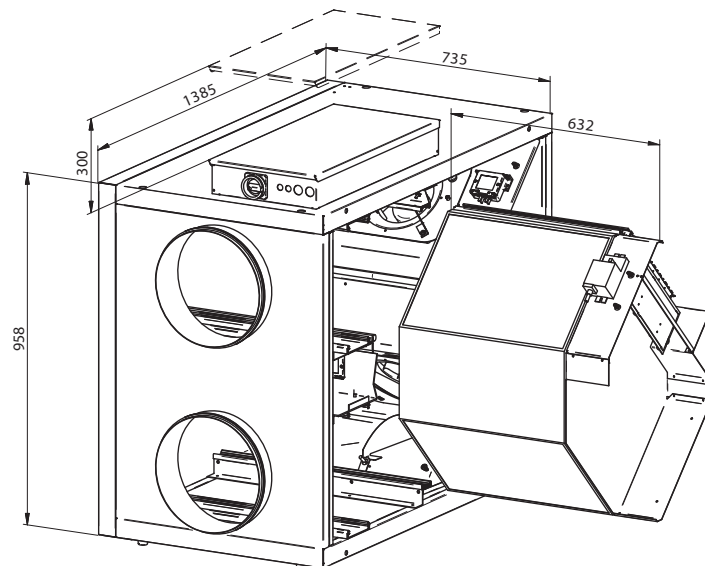

RD1 2032-02

NB

A free height of at least 300 mm is required above the unit's connection box for servicing.

1.3.2 Requirements for underlying surface

When fitting the unit directly to an existing surface - i.e. without using the mounting base (accessory) - the surface must be:

- level
- horizontal (± 3 mm per metre)
- hard
- vibration-resistant

Condensation outlet

A condensation outlet must be installed in the immediate vicinity of the unit. See also "Mechanical assembly" section.

1.3.4 Requirements for duct system

Silencers

The duct system must be fitted with silencers specified by the Project Manager, which meet the requirements of the operating area.

Bends

A duct bend may be fitted immediately after the unit, because the airflow in the spigot has a uniformly moderate speed profile, which results in negligible system pressure loss.

Insulation

The duct system must be insulated against:

- **condensation**
 - **sound leakage**
 - **heating/cooling losses**
-

Condensation

Condensation in the ducts may occur when the exhaust/outdoor air has high humidity. EXHAUSTO recommends a condensation outlet is also fitted at the lowest point in the ducts.

No duct connection

If one or more of the spigots is not connected to a duct: Fit a protective net to the spigots with a maximum mesh width of 20 mm.

1.4 Description

1.4.1 Construction of the VEX unit

The drawing below shows an overview of the VEX unit construction. The drawing shows a right-hand version of the VEX.

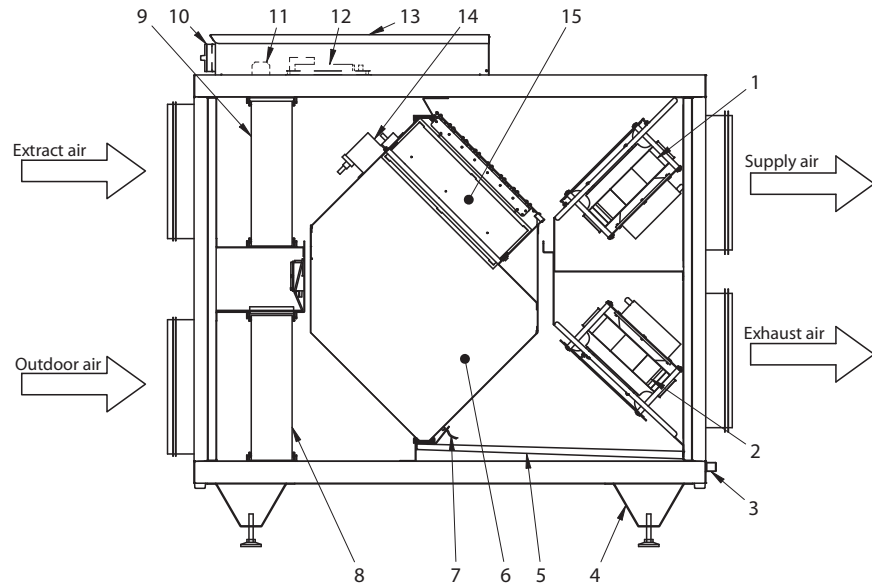

RD12040GB-02

Pos.	Part	Function
1	Supply air fan	Blows air into the room
2	Exhaust air fan	Removes "stale" air
3	Condensation outlet spigot	Conducts condensate away from the condensation tray. External condensation outlet connects here.
4	Base	Accessories
5	Condensation tray	Collects the condensate and drains it away from the cross-flow heat exchanger to the condensation outlet
6	Counter flow heat exchanger	Qty. 1 aluminium counter flow heat exchanger
7	Icing monitor	Measures the temperature in the counter flow heat exchanger, so the control system can prevent icing
8	Outdoor air filter	Filters outdoor air
9	Extract air filter	Filters extract air
10	Isolation switch	Connects/disconnects current
11	Terminals	Connection of ventilation components
12	EXact2 control	Control system
13	Connection box	Connection of accessories
14	Bypass motor	Opens/closes bypass damper
15	Bypass duct	Directs air around the counter flow heat exchanger

1.4.2 Parts of the VEX unit

Cabinet	The inside and outside of the cabinet is made of Aluzinc® and insulated with 50 mm mineral wool.
Fans	The unit contains two centrifugal fans with backward curved blades for extract air and supply air.
Counter flow heat exchanger	The unit's counter flow heat exchanger is made of aluminium and is highly efficient. The counter flow heat exchanger can be removed and cleaned.
Filters	The unit includes integral compact filters for both extract air and supply air.
Bypass damper	The unit has an integral variably adjustable bypass, allowing for precise control of the supply air temperature.

1.5 Principal dimensions

1.5.1 Dimensioned sketch

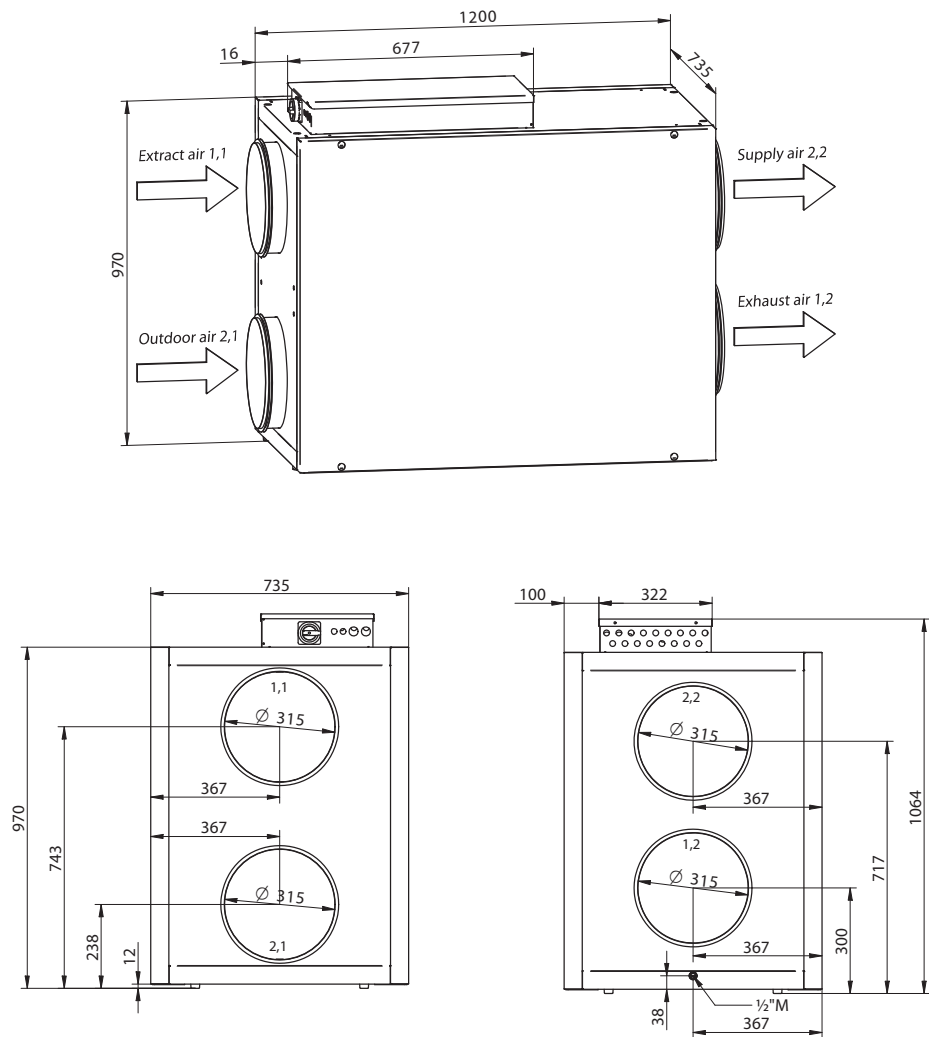

RD130756GB-01



2. Handling

2.1 Unpacking

Supplied components

The following components are supplied:

- VEX unit
- Supplied accessories (as indicated in the checklist on the front page of the instructions)

Packaging

The unit is delivered on a disposable pallet and packed in clear plastic.

NB

Once the plastic has been removed, the unit must be protected against dirt and dust:

- **The covers on the spigots must not be removed until the spigots are connected to the ventilation ducts.**
- **Whenever possible, keep the unit closed during fitting.**

The unit should be cleaned before it is used.

Once the VEX unit is fitted, it must be checked and thoroughly cleaned. All dust, debris and metal shavings must be vacuumed up.

2.1.1 Weight

The VEX unit weighs:

- VEX330H-1: 153 kg.
- VEX330H-2: 156 kg.

2.2 Transport



Transport

Transport the VEX unit on the disposable pallet. Do not lift it with the spigots or connection box.

Transport methods

Transport the VEX unit in one of the following ways:

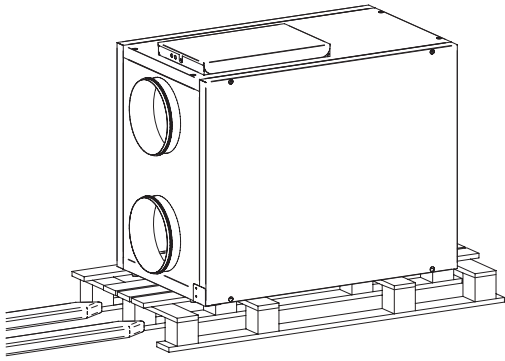
Method	Drawing
<p>Manual transport: Lifting brackets for manual transport can be fitted as shown on the drawing:</p>	

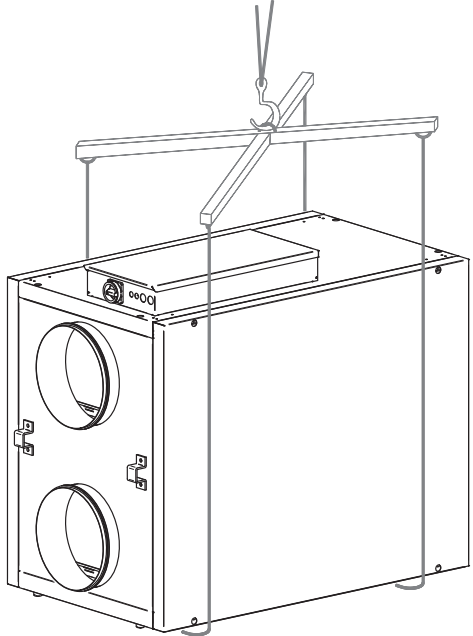
Method	Drawing
<p>Using lifting truck or fork-lift truck: Lift the VEX unit on the disposable pallet. IMPORTANT: If the disposable pallet cannot be used, the forks on the lifting equipment must be long enough to prevent damage to the bottom of the unit.</p>	
<p>Crane:  Never lift the VEX unit with the lifting brackets by using a crane. Use straps and lifting yokes to prevent damage to the unit.</p>	

2.2.1 Passage through openings

Unit dimensions

The list (below) shows the unit's dimensions, and is intended to indicate how large an opening has to be for the unit to pass through:

	Length	Width	Height inc. connection box
VEX330H	1200 mm	735 mm	1070 mm, including connection box 100 mm

2.2.2 Internal transport with reduced weight

Weight reduction

The weight can be reduced during transport by removing fans, counter flow heat exchanger and one of the doors. The table below shows the how much weight can be reduced by removing the various parts.

Parts	Weights, VEX330H-1	Weights, VEX330H-2
Fan, 2 items at	5.0 kg = 10 kg	6.5 kg = 13 kg
Counter flow heat exchangers, 1 item at	14.5 kg	14.5 kg
Door/removable panel, 1 item at	30 kg	30 kg
Total weight, VEX330H	153 kg	156 kg

Dismounting

See section "Maintenance" for instructions for dismounting doors, fans and counter flow heat exchanger and for removal of filters.



3. Mechanical assembly

3.1 Positioning of unit

Installation directly on floor

Floors must meet the requirements in section "Requirements for underlying surface". If the floor surface does not meet those requirements, then the VEX300H must be installed on a suitable base - described below.

NB: After installation, make sure that the air handling unit is completely level

3.1.2 Subsequent installation of base

How to install the base

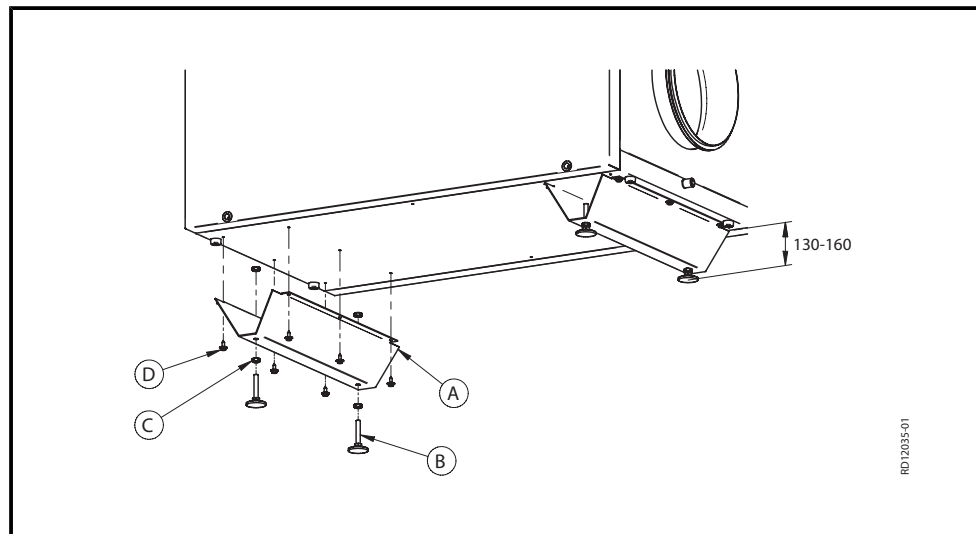

Step	Action
1	Lay the unit on its side - on one of the detachable panels
2	Screw adjustable screws (B) and washer (C) into the base (A)
3	Screw base (A) firmly to the holes in the cabinet, using 6 screws (D)
4	Adjustable screws (B) can adjust the height by up to 30 mm

3.2 Condensation drain



Drain the condensation outlet into a floor gully or similar. The condensation outlet must be fitted with a water trap. See below.

Risk of frost



Where there is a risk of frost: Insulate the condensation outlet and protect it against frost - if necessary, using a heating cable.

3.2.1 Establishment of condensation outlet

Location

The drawing below illustrates the correct positioning of the water trap from the condensation outlet.

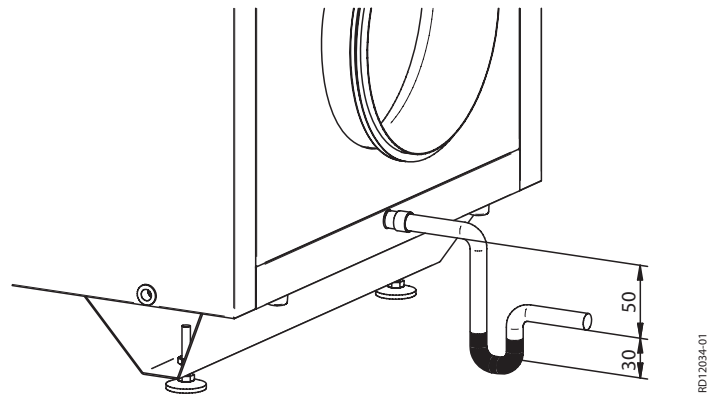
**NB:**

When VEX330H is mounted on a base, there is sufficient free height to accommodate the water trap.



4. Electrical installation

4.1 Electrical installation

See the attached instructions "Electrical installation guide for VEX320C/330C/330H with EXact2 control system":

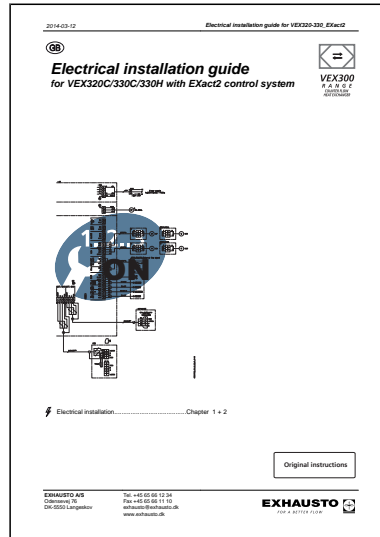



5. Maintenance, hygiene and servicing

5.1 Operating readings via the HMI panel

HMI panel

Refer to the "EXact Basic Instructions for the VEX320/330/340/350/360" for instructions on accessing Menu 2 Operating readings via the technician menu (access code 1111) to check the unit's operating status.

5.2 Maintenance

One of the VEX unit's detachable panels must be opened to allow servicing and cleaning.



Disconnect power at the isolation switch before opening VEX.

5.2.1 Opening the VEX unit

How to open VEX330H

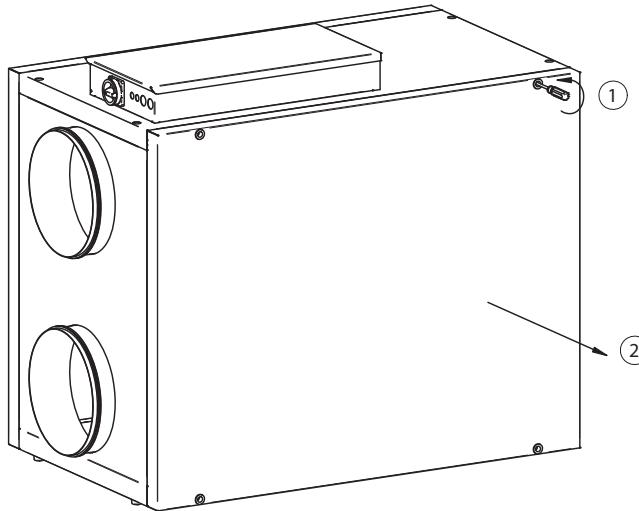

RD1.2033-02

Step	Action
1	Unscrew the bolts from the detachable panel (M8 bolts, bit NV 6 mm) Only dismantle one panel as the cabinet becomes unstable if both are dismantled If the heat exchanger needs taking out, it is an advantage to remove the panel opposite the connection box (above the unit). This avoids dismantling of the bypass damper.
2	Remove the panel
3	Service the VEX unit After servicing - check sealing strip for damage - replace the panel and fix the bolts

5.2.2 Overview of maintenance intervals

The following chart details the recommended maintenance intervals, based on normal operation. EXHAUSTO recommends maintenance is adjusted to suit the actual operating requirements.

Component	Procedure	Twice a year	Once a year
Filters*	Change filters when HMI displays filter alarm. We recommend that both filters are changed at the same time. NB: The control system may give an 'early warning' when a filter is becoming soiled, so that a new filter can be obtained or a service fitter called Filters should be changed at least:	X	
Filter guide	Check that all the seals are tight		X
Seals and sealing strips	Check that all the seals are tight		X
Fan	Check Remove the fan unit. See section "Internal transport with reduced weight" Cleaning. See next section		X
Counter flow heat exchanger	Cleaning, see next section		X
Heating coils (accessory)	Clean the heating coil, see next section		X
Safety features	Checks on fire thermostats/smoke gas detectors		X
Closing damper	Function inspection		X
Condensation outlet	Check that the outlet works by pouring water in the condensation tray		X

*Filters



Only use original filters

- The provided filter data and pressure loss graphs (section "Technical data") are based on the use of original filters
- EUROVENT certification is only valid if original filters are used
- Use of non-original filters may cause leakage in the VEX and impair filter function
- EXHAUSTO recommends that you register the filter replacement date to ensure filters are replaced at the correct intervals

5.3 Hygiene

VDI6022 air hygiene standard

VEX320/330 has been designed to comply with air hygiene standard VDI6022. This means that:

- bacterial growth and dirt accumulation is minimal
- conditions for cleaning are optimum

F7 filter

According to VDI6022 the filter on the outdoor air side must be an F7 filter.

5.4 Servicing and cleaning

5.4.1 Filter change



Disconnect power at the isolation switch before opening VEX.

For opening the VEX unit, see section 5.1.



Pull the filters out. Remember to check the flow direction - see the arrows on the filter.

Servicing and cleaning the motor

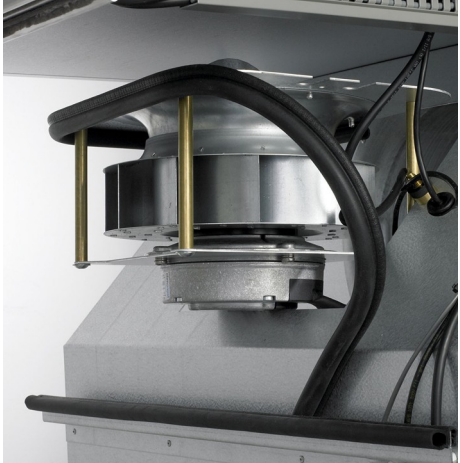

Disconnect power at the isolation switch before opening VEX.

How to remove the motor

Step	Action	Illustration
	<ul style="list-style-type: none"> ● Pull out the safety split pins ● Unscrew the nuts ● Lift the motor section free of the ventilator panel <p>⚠ NB: The motor section weighs: VEX300H-1: 5 kg VEX300H-2: 6.5 kg</p>	
2	<ul style="list-style-type: none"> ● The motor section is removed, and then turned, to access the connector ● Detach the cable by loosening the sealing strip around the motor section's base plate 	
	<ul style="list-style-type: none"> ● Unscrew the plug from the motor block ● Lift out the motor 	
3	<p>Cleaning:</p> <ul style="list-style-type: none"> ● Clean the impeller by vacuum cleaning - and if necessary, finish off with a damp cloth ● Clean the impeller blades carefully to avoid imbalance 	
4	<p>After cleaning: Check that the VEX unit works without vibrations</p>	

5.4.3 Cleaning the condensation tray

How to clean the condensation tray

Step	Action
1	Dismount the condensation tray by releasing the four corner screws
2	Loosen the four screws that hold the condensation outlet
3	Then pull out the condensation tray for cleaning
NB:	Clean the base of the VEX at the same time, as this is otherwise inaccessible because of the condensation tray.

5.4.4 Removing and cleaning the counter flow heat exchangers

Warnings



Disconnect power at the isolation switch before opening the doors.



Take care, as the counter flow heat exchanger is heavy - weight 14.5 kg

How to remove the counter flow heat exchangers





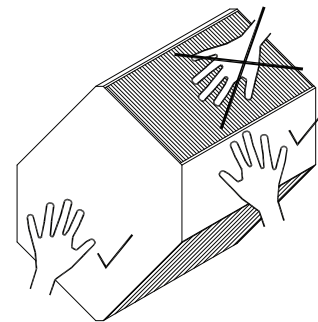

The counter flow heat exchanger fins can be easily damaged - avoid contact with the fins.

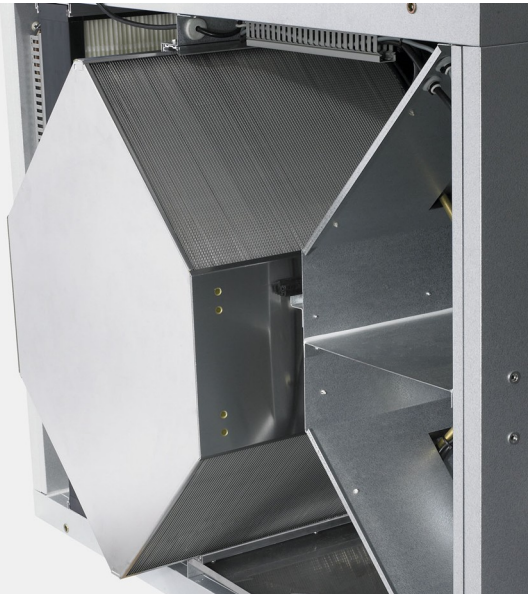

The counter flow heat exchanger can be removed from both sides of the unit. Choosing the side that is opposite the connection box on top of the unit avoids having to remove the bypass damper.

How to remove the counter flow heat exchanger

Step	Action	Illustration
1.	<ul style="list-style-type: none"> • Set the bypass damper at the open position (horizontally at the front of the exchanger) Do this by activating the button (see photo) on the bypass motor, after which the damper is turned to the horizontal position and the shutters are closed • Unscrew the bypass motor and place it on top of the unit 	
2.	<ul style="list-style-type: none"> • Carefully remove the bypass (do not wrench it out) 	
3.	<p>Remove the counter flow heat exchanger all the way:</p> <p>Cleaning</p> <ul style="list-style-type: none"> • Clean the exchanger by flushing with hot water. Water temperature max. 90°C. 	

Step	Action	Illustration
4.	<ul style="list-style-type: none"> • Fit the bypass damper again. • Check the top of the damper shutter fits properly in the guide 	

5.4.5 Cleaning the heating coils

How to clean the electric heating coil

Step	Action
1	Switch off the power supply to the unit at the isolation switch
2	Vacuum clean the heating coil
3	Check the electrical connections

How to clean the water heating coil

Step	Action
1	Switch off the power supply to the unit at the isolation switch
2	Brush and vacuum clean the heating coil
3	If necessary, clean with soap and water



6. Technical data

6.1 Weight, corrosion class, temperature ranges, etc.

Weight

Doors	2 x 30.0 kg
Counter flow heat exchanger	1 x 14.5 kg
Motor section, Type 1	2 x 5.0 kg
Motor section, Type 2	2 x 6.5 kg
Total weight, motor type 1	153.0 kg
Total weight, motor type 2	156.0 kg

Corrosion class

Corrosion class	Corrosion class C4 in accordance with EN ISO 12944-2
-----------------	--

Temperature ranges

Outdoor air temperature	-40°C - +40°C
Ambient temperature (operating)	-30°C - +40°C
Ambient temperature when not in operation (storage, transport)	-40°C - +60°C

The temperature ranges given are dependent on the type of installation, humidity, airflow, the balance between airflows, ducts and insulation and room temperature. If using pre-heating coils, the ambient temperature can be reduced.

At temperatures below -25°C (with outdoor installation), use of a thermostatically controlled heater in automated control box is recommended.

HMI-panel

Ingress protection	IP20
Ambient temperature	0°C - +50°C

At temperatures below 0°C the display may react more slowly than usual.

Fire thermostats

Cut-out temperature, BT70	70°C
Cut-out temperature, BT50	50°C
Cut-out temperature, BT40	40°C
Max. ambient temperature, sensor	250°C
Ambient temperature, thermostat housing	0°C - +80°C
Sensor length	125 mm
Ingress protection	IP40

Motor damper

Motor damper type	LS (closing damper)	LSR (closing damper, spring return)
Type	LS315-24	LSR315-24
Designation	LSA/LSF	LSFR
Motor type	NM24-F	AF-24
Rotation time	75–150 s	open: 150 s close: 16 s
Ingress protection	IP42	IP42
Ambient temperature	-20°C to +50°C	-30°C to +50°C
Damper depth	100 mm	100 mm

A maximum of two LSFR dampers or four LSA/LSF dampers may be connected.

6.2 Compact filters

Filter data, VEX330H

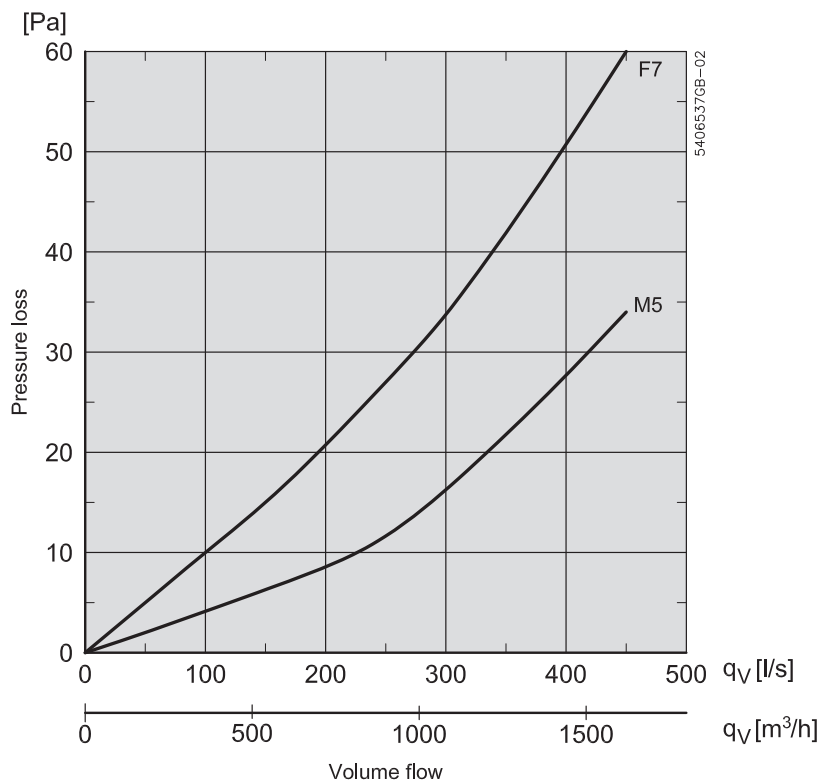

Data	Device	VEX330H-1		VEX330H-2	
		M5	F7	M5	F7
Dimensions: h x w, 1 item per air direction	mm	340 x 630		340 x 630	
Thickness of compact filter	mm	96		96	
Filter area	m ²	2,5	7,7	2,5	7,7
Filter class		M5	F7	M5	F7
Retention efficiency in accordance with EN779	%	96	> 99	96	> 99
Efficiency	%	45	85	45	85
Volume flow rate	m ³ /h	900		1500	
Initial pressure drop	Pa	15	30	35	60
Recommended final pressure drop at normal volume flow rate	Pa	115	130	125	150
Temperature resistant to	°C	70		70	



EUROVENT certification is only valid if original filters are used. For more details about original filters, see section "Maintenance".

6.3 Capacity diagram

6.3.1 Capacity diagram, VEX330H-1

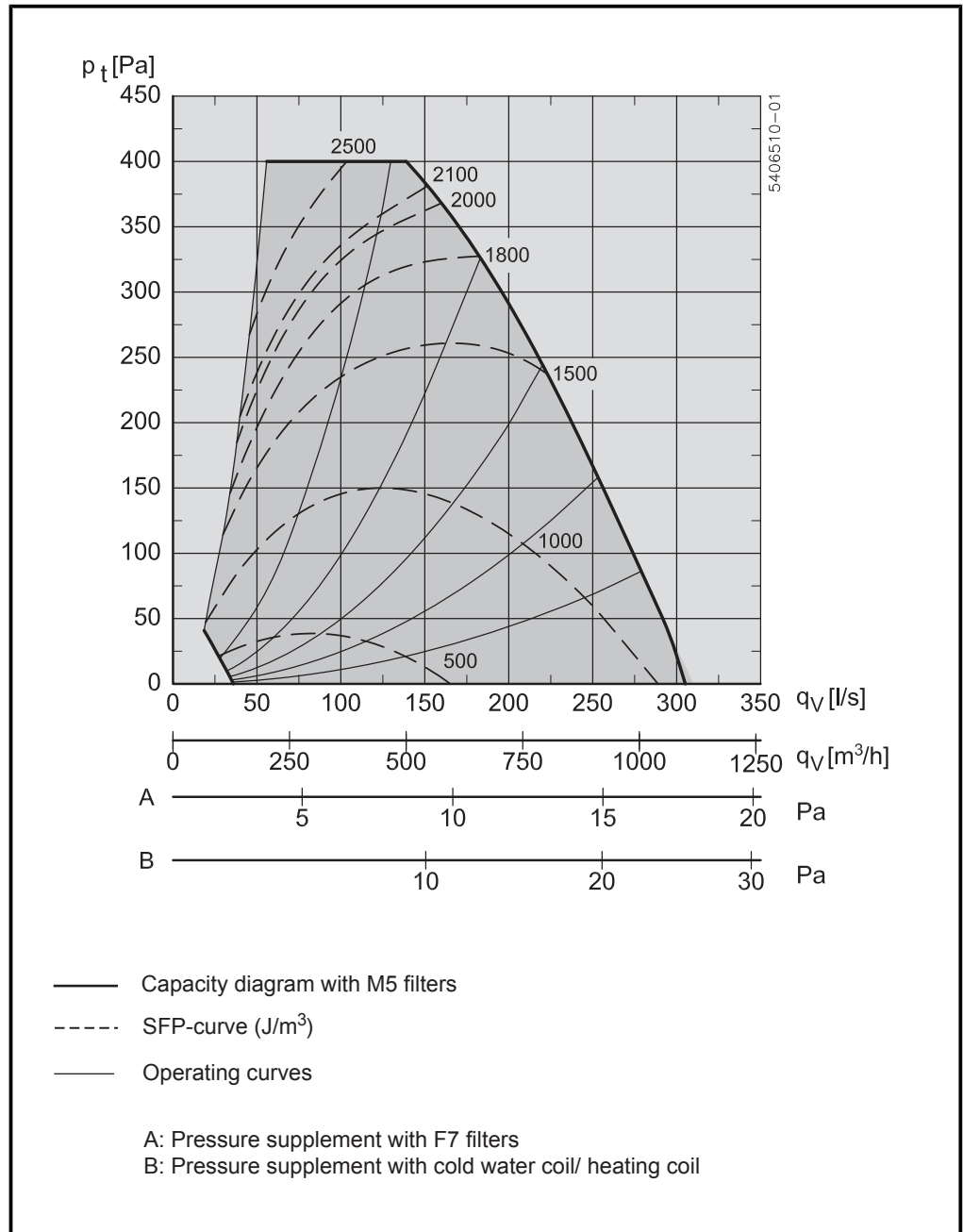

6.3.2 Capacity diagram, VEX330H-2

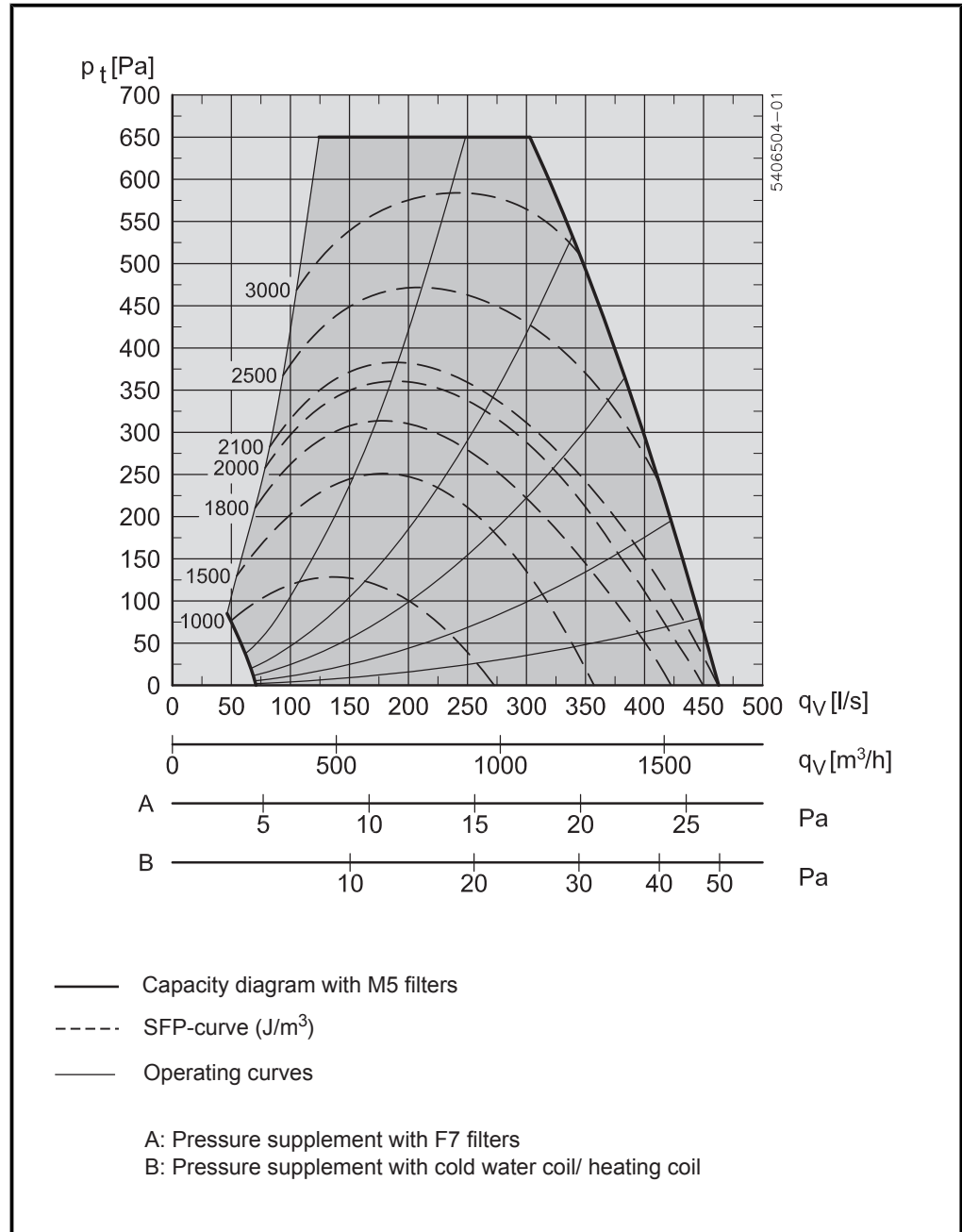

6.4 EC Declaration of Conformity

See document no. 3004286, Declaration of Conformity. The document is supplied together with the other product documentation. It is also available on the EXHAUSTO website (search using document no.)

6.5 Ordering spare parts

Find production number

To be able to supply the correct spare part for the specific VEX unit, the production number must be given when ordering the spare part. The production part number is written on the front page of the instructions supplied with the unit. It is also included on the information plate.

Contact

Contact your local EXHAUSTO distributor to order a spare part. The telephone number is shown on the back cover of these instructions. If required, see chapter 1, section "The VEX unit's design" for an overview of terms and of the positions of parts.



Scan code and go to addresses at
www.exhausto.com