

GB

VEX360H

with EXact2 control system



Unit supplied with (factory fitted):

- FB bag filter
- FP compact filter
- OD - roof for outdoor
- Mounting base (unassembled)
- Webserver
- MLON





The following accessories are supplied separately:

- HCW external heating coil (water)
- HCE external heating coil, _____ kW
- CCW cold water coil
- Closing damper, LS500 (LSF outdoor air)
- Closing damper, LS500, (LSA exhaust air)
- Closing damper, LSR500, with spring-return (LSFR outdoor air)
- closing damper, LSR500, with spring-return (LSAR exhaust air)
- pieces, BT40 fire thermostat
- pieces, BT50 fire thermostat
- pieces, BT70 fire thermostat
- pieces, HMI control panel
- pieces, MIO-PIR motion sensor
- pieces, MPTH-DUCT constant pressure control
- MIO-RH humidity sensor
- MIO-CO2-ROOM, CO₂-sensor
- MIO-CO2-DUCT, CO₂-sensor
- MIO-TS-DUCT temperature sensor
- MIO-TS-ROOM , temperature sensor
- MXCU control for external cooling unit
- _____

Serial no.: _____

Prod. order no.: _____

Sales order no.: _____

-  Product information.....Chapter 1 + 6
-  Mechanical assembly.....Chapter 2 + 3
-  Electrical installation.....Chapter 4
-  Maintenance.....Chapter 5

Original instructions



1. Product information

1.1. Designations used in these instructions.....	5
1.1.1. Model overview.....	5
1.1.2. Designations used in these instructions.....	6
1.2. Application.....	7
1.3. Location requirements.....	7
1.3.1. Space requirements.....	8
1.3.2. Requirements for underlying surface.....	8
1.3.3. Outlet.....	8
1.3.4. Requirements for duct system.....	8
1.4. Description.....	9
1.4.1. Design.....	9
1.5. Main aim.....	11
1.5.1. Dimensional drawing.....	11



2. Handling

2.1. Unpacking.....	14
2.2. Transport.....	14
2.2.1. Passage through openings	14
2.2.2. Internal transport with reduced weight.....	15



3. Mechanical assembly

3.1. Installing the unit.....	18
3.1.1. Assembly instructions.....	18
3.1.2. Step 1–4.....	19
3.2. Condensation drain.....	24
3.2.1. Condensation outlet.....	24



4. Electrical installation

4.1. Electrical installation.....	26
--	-----------



5. Maintenance

5.1. Operating readings via the HMI panel.....	27
5.2. Maintenance Schedule.....	27
5.3. Hygiene.....	28
5.4. Service.....	28
5.4.1. Filter change.....	28
Removing the counter flow heat exchangers.....	28
5.4.2. Servicing and cleaning.....	32



6. Technical data

6.1. Weight, corrosion class, temperature ranges.....	33
6.2. Compact filters.....	34
6.3. Bag filters.....	35
6.4. Capacity diagram.....	36
6.4.1. Capacity diagram, ventilation with heat recovery.....	36
6.4.2. Capacity diagram, ventilation with bypass operation.....	37
6.5. Ordering spare parts.....	37

Symbols, terms and warnings

Prohibition symbol



Failure to observe instructions marked with a prohibition symbol may result in serious or fatal injury.

Danger symbol



Failure to observe instructions marked with a danger symbol may result in personal injury and/or damage to the unit.

Scope

This instruction manual is for use with EXHAUSTO VEX-type air handling units. Please refer to the product instructions regarding accessories and extra equipment.

The instructions must be fully observed to ensure personal safety and to protect the equipment and ensure its correct operation. EXHAUSTO A/S accepts no liability for accidents caused by equipment not used in accordance with the manual's instructions and recommendations.

Supply air/extract air

These instructions use the following terms as given in DS447-2013:

- Supply air (air blown in)
- Extract air (air removed)
- Outdoor air
- Exhaust air

Left/Right

The term R for Right, indicates the supply air is to the right of the cooling unit, as seen from the operating side. The term L for Left, indicates the supply air is to the left.

Front page: Accessories

The front page of the instruction manual contains a checklist, detailing the accessories delivered with the VEX unit.

NB

When retrofitting EXHAUSTO accessories, please update the checklist on the front page.

Warnings

Opening the air handling unit



Do not open the service doors until the supply voltage has been disconnected at the isolation switch and the fans have stopped. The isolation switch is positioned on the left side of the connection box on top of the unit.

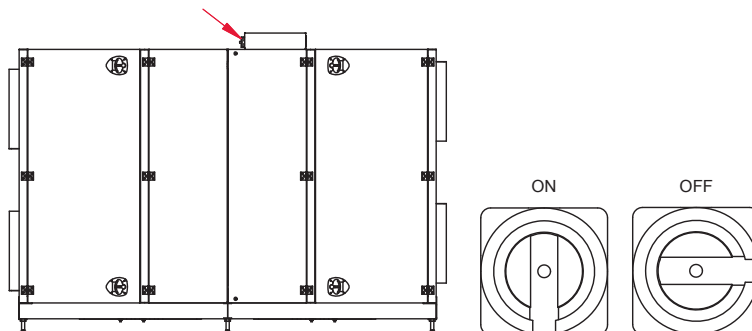

RE12738-01

No duct connection

If one or more of the spigots is not connected to a duct: Fit a protective net to the spigots with a maximum mesh width of 20 mm (in accordance with EN294).

Lock the air handling unit during operation

The VEX unit must always be locked during operation:

- Use the cylinder lock in the handle. **Remember** to remove the key from the lock.
- Or use a padlock. Use the handle's built-in padlock fixture.

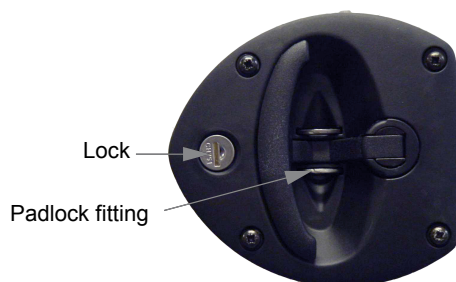
**Typeskilt**

På VEX-aggregatets typeskilt kan aflæses:

- hvilken VEX-variant (1) aggregatet er
- aggregatets produktionsordrenr. (2)

EXHAUSTO A/S <small>Østergade 10, DK-2600 Lyngby, DK-2600 Tlf: +45 3342 1111 Fax: +45 3342 1232</small>		CE	
Type	V350HREC	1	10A - 10kVA
	No./Year: 1234567/2011	2	
Supply	Voltage: 3x230V+PE/3x400V+N+PE ~50Hz	Current:	15A/15A

Bemærk



Hav produktionsnummeret parat ved alle henvendelser til EXHAUSTO om produktet.



1. Product information

1.1 Designations used in these instructions

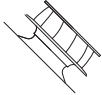
1.1.1 Model overview

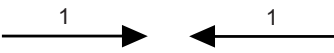
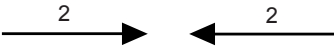
Elements	Explanation
	Fan
	Compact filter
	Bag filter
1,1,A or B	Extract air spigot
1,2,A	Exhaust air spigot
2,1,A	Outdoor air spigot
2,2,A or B	Supply air spigot
	Air direction, extract air
	Air direction, supply air

NB The sketch shows compact filters

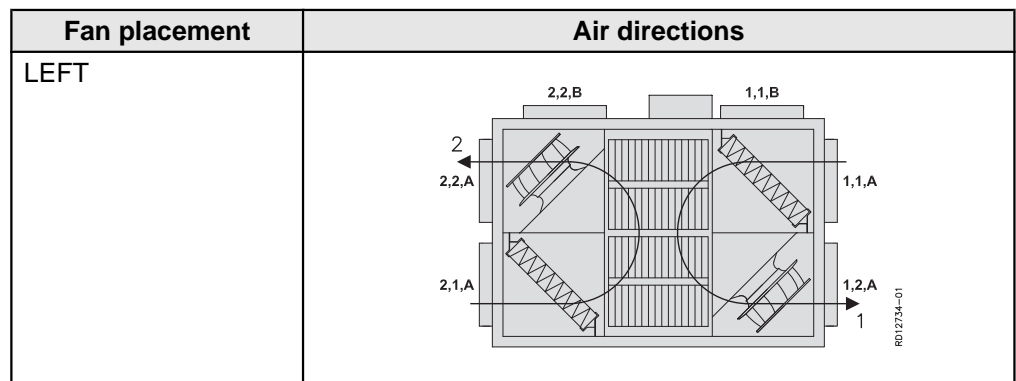

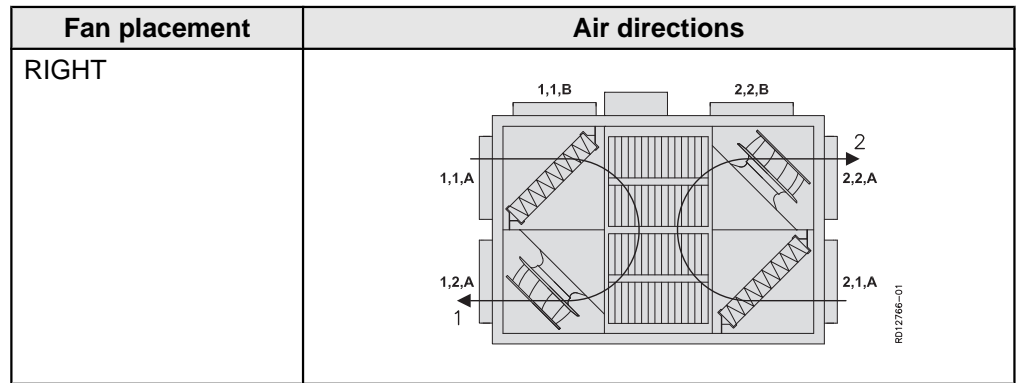

NB Spigot location B option not available with outdoor models.

1.1.2 Designations used in these instructions

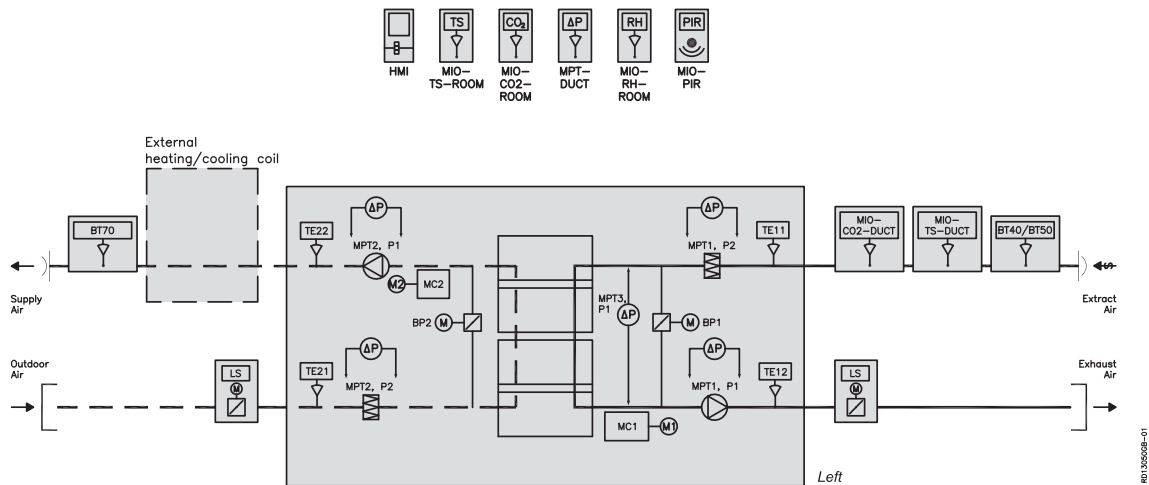

The simplified diagram shows a VEX unit with LEFT fan placement.

Component	Function
BP1	Bypass damper extract air/exhaust air
BP2	Bypass damper outdoor air/supply air
BT40/BT50	Fire thermostat, 40□/50□ (extract air)
BT70	Fire thermostat 70□ (supply air)
MC1	Motor control, motor 1 (extract air)
MC2	Motor control, motor 2 (supply air)
HMI	Control panel
LS	Closing damper, outdoor air/exhaust air
M1	Extract air motor
M2	Supply air motor
MIO-CO ₂ -DUCT	CO ₂ sensor, duct
MIO-CO ₂ -ROOM	CO ₂ sensor, room
MIO-PIR	PIR sensor
MIO-RH-ROOM	Humidity sensor

Component	Function
MIO-TS-ROOM	Temperature sensor, room
MIO-TS-DUCT	Temperature sensor, extract air (external)
MPT1, P1	Airflow control, extract air
MPT1, P2	Filter monitor, extract air
MPT2, P1	Airflow control, supply air
MPT2, P2	Filter monitor, outdoor air
MPT3, P1	Ice detection
MPT-DUCT	Pressure transmitter, constant pressure regulation
TE11	Temperature sensor, extract air
TE12	Temperature sensor, exhaust air
TE21	Temperature sensor, outdoor air
TE22	Temperature sensor, supply air

1.2 Application

Comfort ventilation EXHAUSTO VEX is used for comfort ventilation tasks. Operating temperature range for the unit – see section "Technical data".

Prohibited uses The VEX unit is not to be used to transport solid particles or in areas where there is a risk of explosive gases.

1.3 Location requirements

Positioning The air handling unit is designed for indoor fitting. The air handling unit can be ordered for outdoor installation (accessory Outdoor, OD).

1.3.1 Space requirements

The drawing below indicates how much space is required to open the side-mounted doors for servicing, replacing filters, cleaning, etc. The drawing shows compact filters.

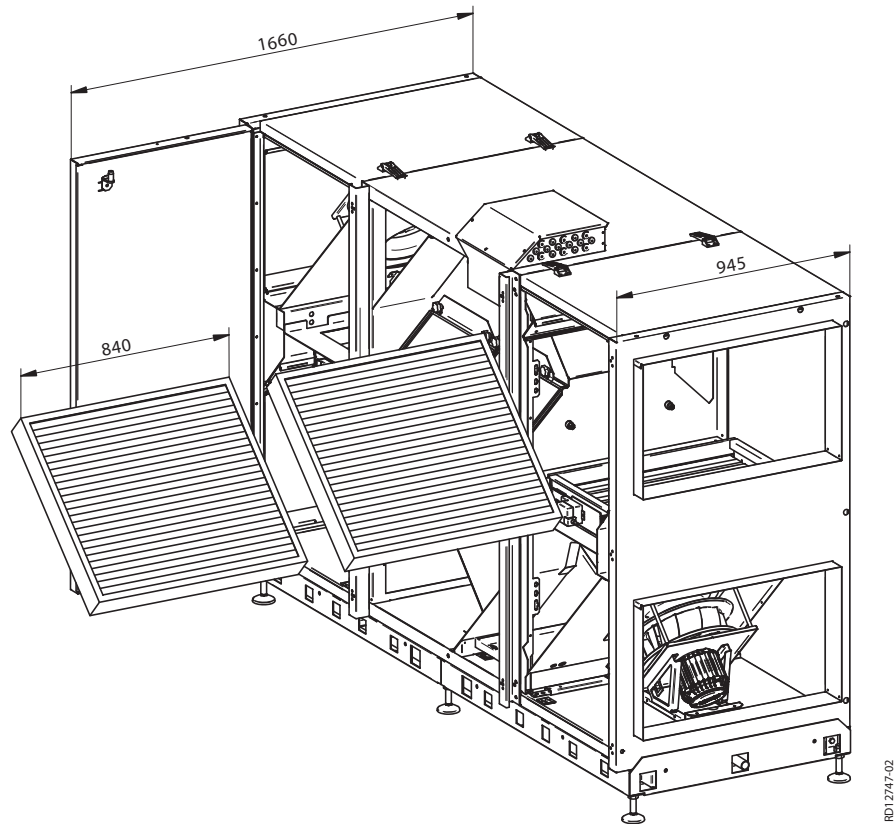

NB

For servicing purposes, a free height of at least 200 mm is required above the unit's connection box.

1.3.2 Requirements for underlying surface

When floor-mounting the unit, the surface must be:

- level (+/- 10 mm per metre)
- hard
- resistant to vibration

The VEX unit leg height can be adjusted: 55–110 mm.

1.3.3 Outlet

A condensation outlet must be installed in the immediate vicinity of the unit. See also "Mechanical fitting" section.

1.3.4 Requirements for duct system

Silencers

The duct system must be fitted with silencers specified by the Project Manager, which meet the requirements of the operating area.

Bends

A duct bend may be fitted immediately after the unit, because the airflow in the spigot has a uniformly moderate speed profile, which results in negligible system pressure loss.

Insulation



The duct system must be insulated against:

- condensation
- sound leakage
- heating/cooling losses

Condensation

Condensation in the ducts may occur when the exhaust/outdoor air has high humidity. EXHAUSTO recommends a condensation outlet is also fitted at the lowest point in the ducts.

No duct connection



If one or more of the spigots is not connected to a duct: Fit a protective net to the spigots with a maximum mesh width of 20 mm.

1.4 Description

1.4.1 Design

Layout drawing, Left model

The drawing below illustrates the construction of the unit, without doors: The drawing shows compact filters.

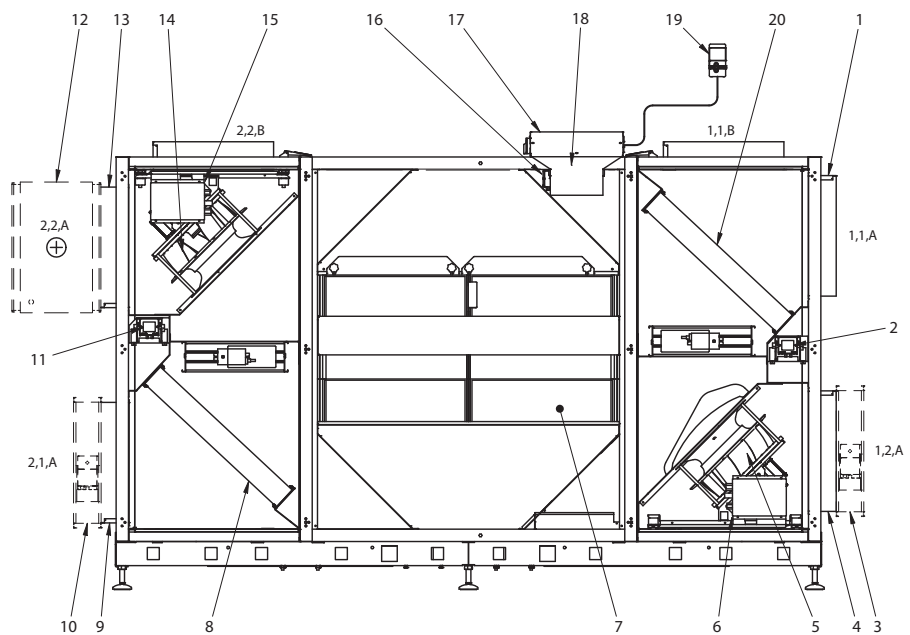

Layout drawing, Right model

The drawing below illustrates the construction of the unit, without doors: The drawing shows compact filters.

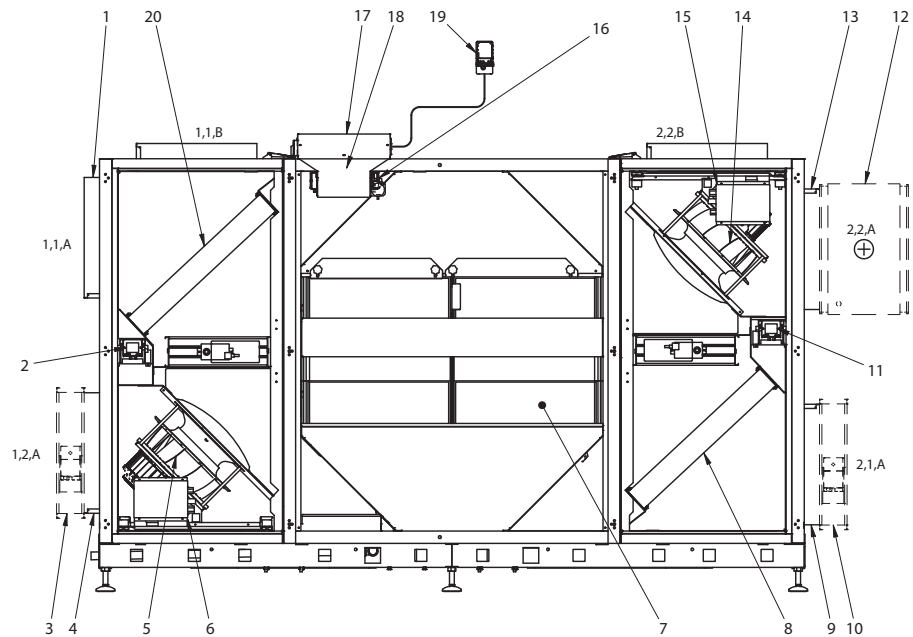

Pos. no.	Part	Function
1	Spigot 1,1,A	Extract air spigot The spigot can also be positioned on the top of the unit (1,1,B). Does not apply to units designed for outdoor fitting
2	MPT1	Measurement of pressure in extract air duct
3	Closing damper LS	Closing damper, exhaust air, LSA (accessory).
4	Spigot 1,2,A	Exhaust air spigot
5	Fan unit, exhaust air	Removes "stale" air
6	Motor control, extract air fan	Variably adjusts fan
7	Counterflow heat exchanger	4 counter flow heat exchangers made from aluminium, conduct the heat from extract air to supply air
8	Outdoor air filter	Filters outdoor air.
9	Spigot 2,1,A	Outdoor air spigot
10	Closing damper LS	Closing damper, outdoor air, LSF (accessory).
11	MPT2	Measures pressure in supply air duct
12	Heating coil	Heats supply air if heat recovery is insufficient (accessory).
13	Spigot 2,2,A	Supply air spigot. The spigot can also be positioned in the top of the unit (2,2,B). Does not apply to units designed for outdoor fitting
14	Fan unit, supply air	Blows air into the room
15	Motor control, supply air fan	Variably adjusts fan

Pos. no.	Part	Function
16	MPT3	Measures pressure loss across the counter flow heat exchanger
17	Connection box	Connection box for supply voltage, external ventilation components, HMI panel, BMS and Ethernet
18	Connection box	Cover plate
19	HMI panel	Operation of the control system
20	Extract air filter	Filters extract air.

Cabinet

The inside and outside of the cabinet is made of Aluzinc® The cabinet is insulated with 50 mm mineral wool.

Fans

The unit contains two centrifugal fans for exhaust air and supply air.

Counter flow heat exchangers

The unit's counterflow heat exchangers are made of aluminium and are highly efficient. The counterflow heat exchangers can be taken out and cleaned. See section "Servicing".

Filters

There are integral panel filters on both the extract air and outdoor air sides.

Bypass design

The unit has a built-in double modulating bypass. In the case of summer operation without heat/cold recovery, both outdoor air and extract air are directed around the heat exchanger to reduce energy consumption.

1.5 Main aim

1.5.1 Dimensional drawing

The sketches show compact filters.

VEX360H, Left

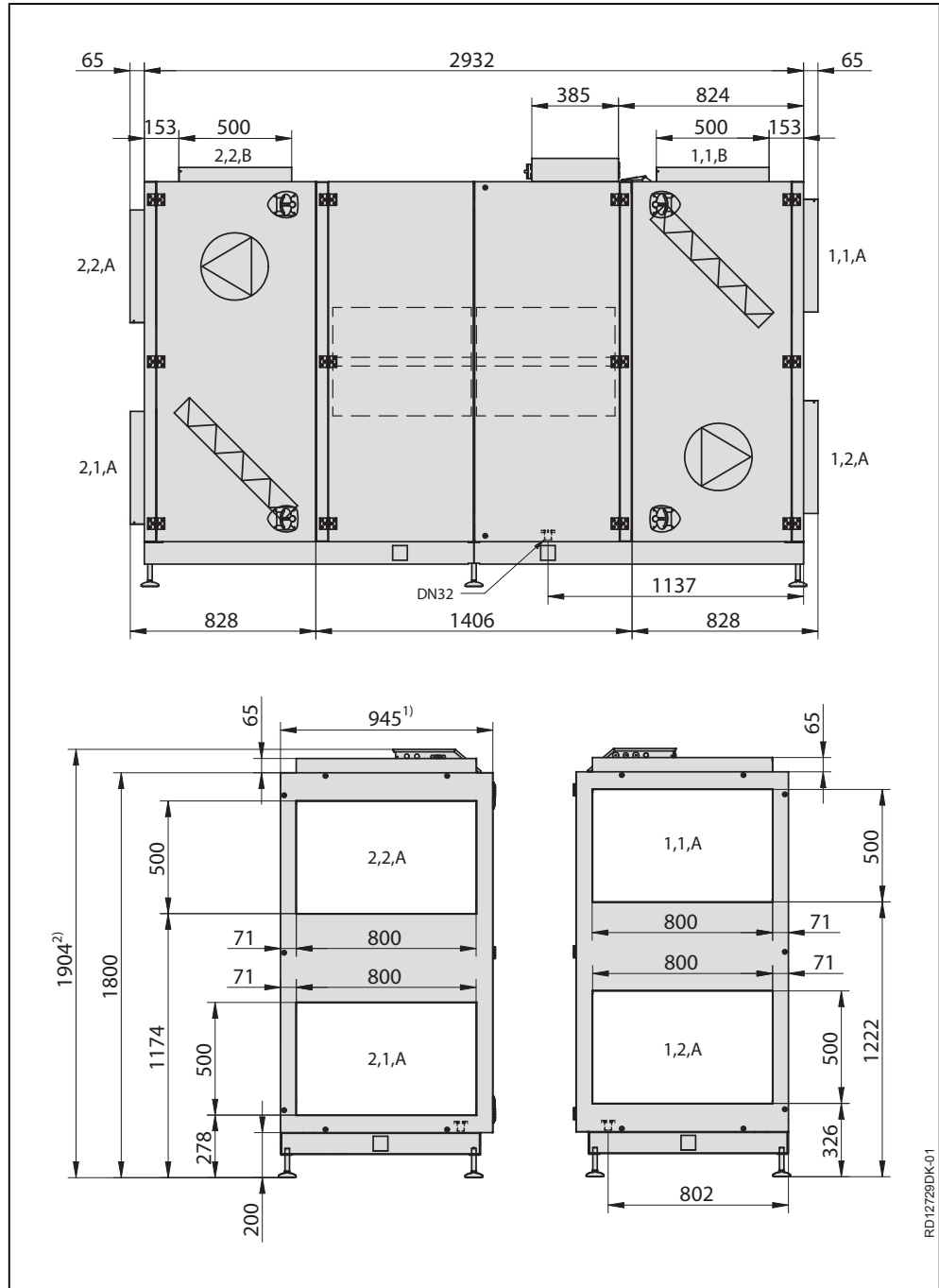

- 1) Allow for space in front of the VEX unit, so the doors can be opened
- 2) Allow for free height over the VEX unit, so the connection box can be serviced
See the section on "Space requirements".

VEX360H, Right

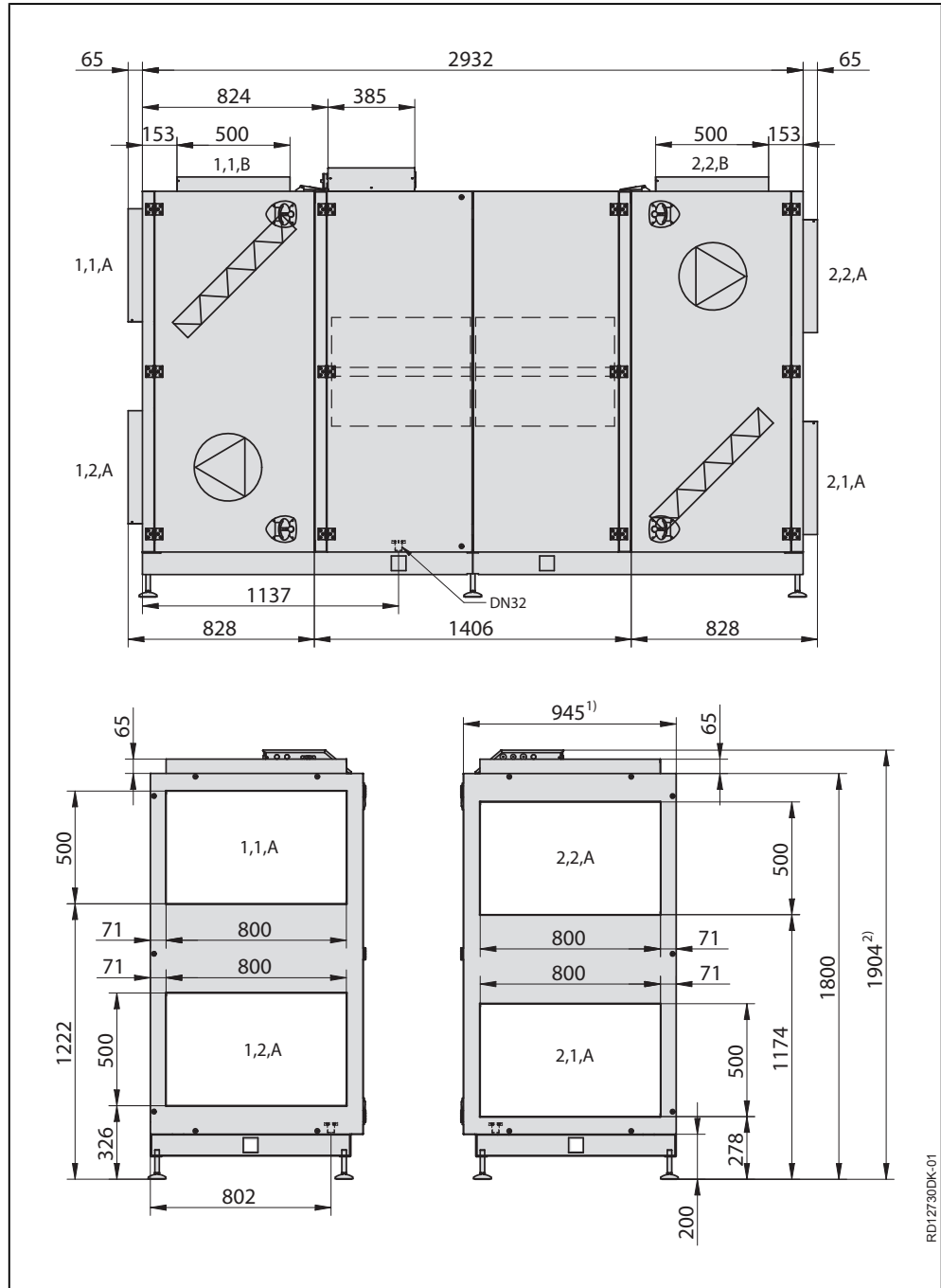

RD12730DK-01

- 1) Allow for space in front of the VEX unit, so the doors can be opened
 - 2) Allow for free height over the VEX unit, so the connection box can be serviced
- See the section on "Space requirements".



2. Handling

2.1 Unpacking

Supplied components	The following components are supplied: <ul style="list-style-type: none"> • VEX unit with associated base. • Supplied accessories (as indicated in the checklist on the front page of the instructions)
Packaging	The unit is delivered in three sections on separate disposable pallets; packed in cardboard and clear plastic. The base is packed in a wooden box.
Unpacking	Depending on the installation site's spatial limitations, unpacking can be done in the following manner: <ul style="list-style-type: none"> • Unpack and assemble the base and sections and subsequently transport the VEX unit to the site or • set up the base at the installation side and mount the sections on the base afterwards. Base assembly is described in section 3.1.
NB	Once the plastic has been removed, the unit must be protected against dirt and dust: <ul style="list-style-type: none"> • The covers on the spigots must not be removed until the spigots are connected to the ventilation ducts. • Whenever possible, keep the unit closed during fitting.
The unit should be cleaned before it is used.	Once the VEX unit is fitted, it must be checked and thoroughly cleaned. All dust, debris and metal shavings must be vacuumed up.

2.2 Transport

Transport equipment	Move the VEX unit using a lifting or fork-lift truck or crane, as described in the instructions "Transport of VEX350-360-370".
----------------------------	--

2.2.1 Passage through openings

The sections' principal dimensions	Measurements are based on the exact dimensions of the VEX unit.
---	---

The VEX unit is shown with compact filters.

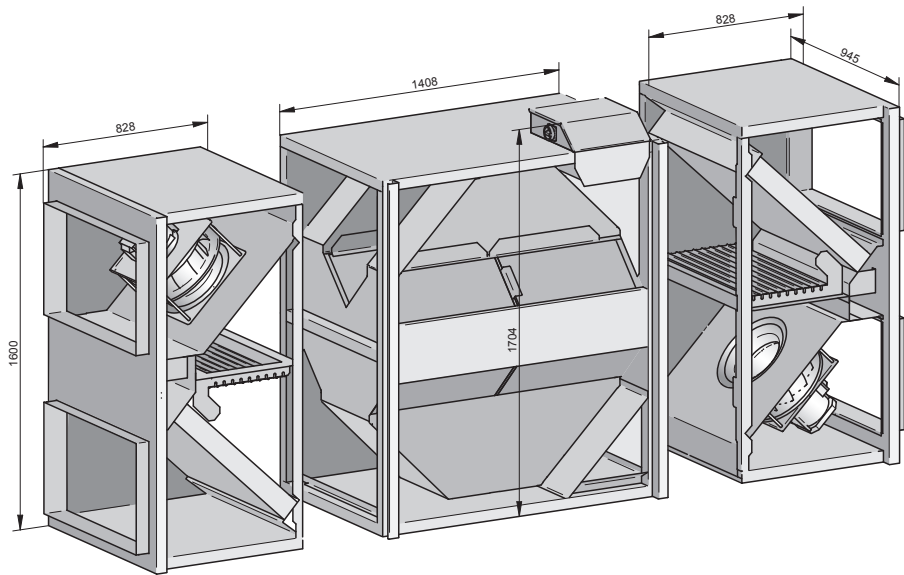

RD12798-01

Width

The list below shows the unit's dimensions, and is intended to indicate how large an opening has to be for the unit to pass through:

If the opening width is	Then
Less than 900 mm	The unit will not pass through
Between 900 - xxxx mm	Remove doors and the support bars which the central doors are fixed to – as described in section "Internal transport with reduced weight".
Greater than xxxx mm	The unit can pass through

2.2.2 Internal transport with reduced weight

Weight reduction

The weight can be reduced during transport by removing the service doors, fan units and counter flow heat exchanger. The table below shows the how much weight is reduced when the subcomponents are removed.

Section	Subcomponents	Weight
Fan section, 2 x 156 kg		
	Fan section, empty cabinet	101 kg
	Door	19 kg
	Fan unit	32 kg
	Compact or bag filters, 2 items of 2 kg weight	4 kg
Exchanger section, 1 x 310 kg		
	Exchanger section, empty cabinet	197 kg
	Counter flow heat exchangers, 4 x 19 kg	76 kg
	Doors, 2 x 18.5 kg	37 kg
Base, 1 x 80 kg		

Section	Subcomponents	Weight
Total weight VEX360 unit		702 kg

Removing the service doors

To remove the service doors:

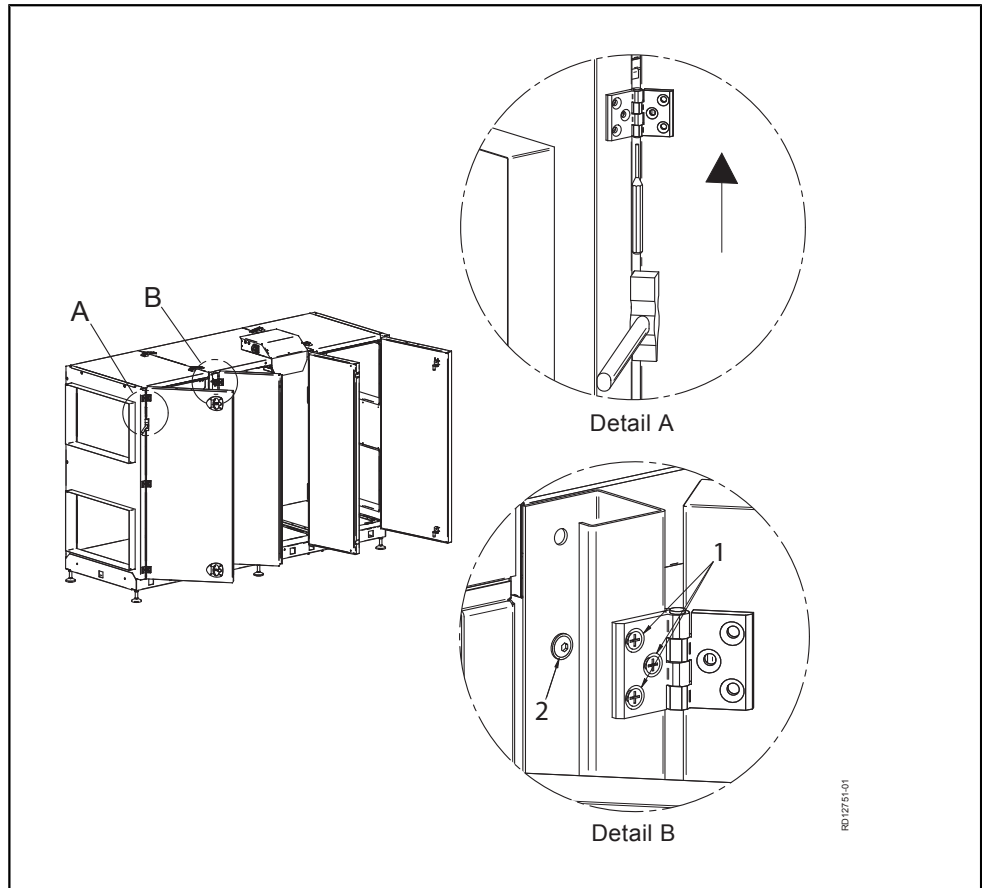

A	<p>How to remove the doors (2 in no.) <u>to the fan sections:</u></p> <ul style="list-style-type: none"> ● Open the door ● Tap the hinge door pin out from below using a small pin bolt or similar ● Lift the door off
B	<p>How to remove the doors (2 in no.) <u>to the heat exchanger sections:</u></p> <ul style="list-style-type: none"> ● Open the door ● Unscrew the door hinge from the support bar (1) and remove the door (be careful as the door is heavy - weighs nearly 19 kg). ● Unscrew the support bar (2)

To remove the fan unit

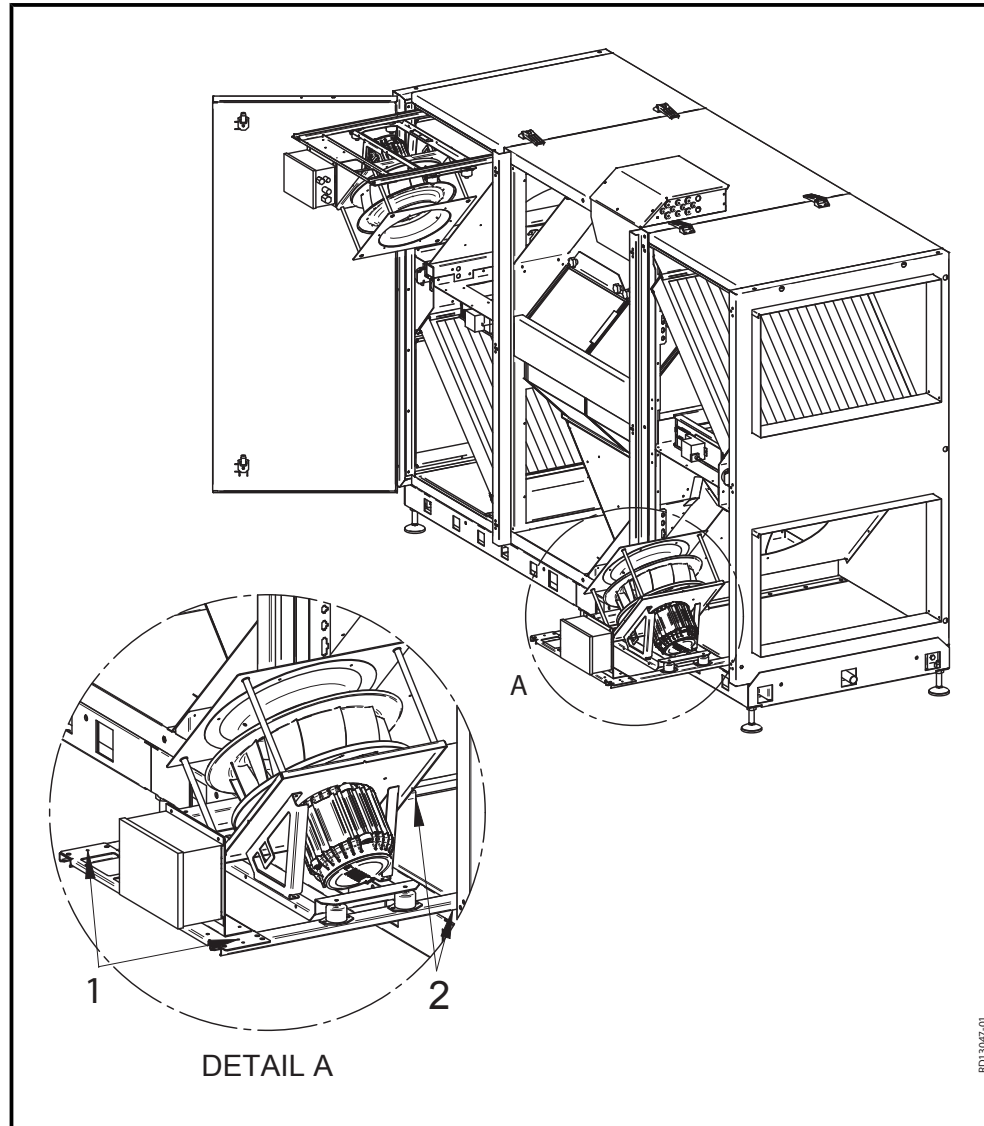

Step	Action
1	Remove the fixing screws (1) on the sliding rail (out towards the operating side)
2	Cut the cable ties holding the motor cable and the cable ties holding the measuring hose
3	Pull the fan unit out to the end-stop (a screw on each rail acts as a stop)
4	Remove the supply cable and the control cable in the motor control.
5	Remove the two end-stops (screws one on the sliding rail (2)). The fan unit can now be lifted off.

NB: A single fan unit weighs 32 kg.

Removing the counter flow heat exchangers

See section "Servicing"



3. Mechanical assembly

3.1 Installing the unit

3.1.1 Assembly instructions

Step 1, assemble the base	
Step 2, push the sections onto the base	Step 3-4, tighten the VEX together











Base



The unit must be assembled on the base – to ensure it is tightened correctly.

3.1.2 Step 1-4

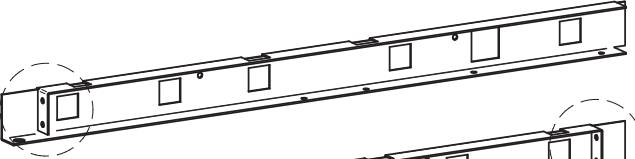
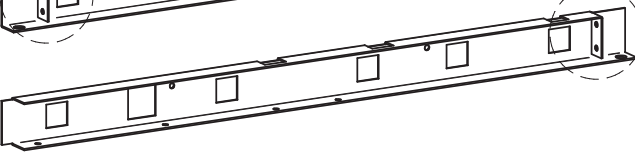
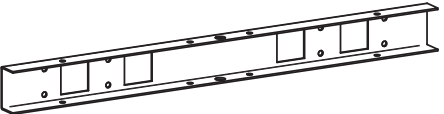
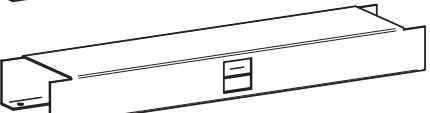
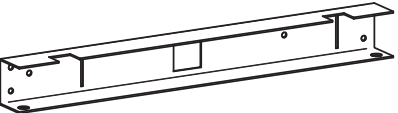
Step 1, Base: Assemble the base as shown in the drawing below.

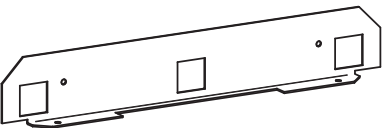
Base assembly	Drawing
<p>The base consists of the following parts:</p>	<div style="display: flex; justify-content: space-around; align-items: flex-start;"> <div style="text-align: center;">  <p>6x</p> </div> <div style="text-align: center;">  <p>6x</p> </div> <div style="text-align: center;">  <p>12x M20</p> </div> <div style="text-align: center;">  <p>12x</p> </div> </div> <div style="display: flex; justify-content: space-around; align-items: flex-start; margin-top: 10px;"> <div style="text-align: center;">  <p>34x M10x25</p> </div> <div style="text-align: center;">  <p>34x M10</p> </div> <div style="text-align: center;">  <p>4x M10x35</p> </div> <div style="text-align: center;">  <p>4x</p> </div> </div> <div style="margin-top: 20px;"> <p>A)  2x</p> <p>B)  2x</p> <p>C)  2x</p> <p>D)  2x</p> <p>E)  2x</p> <p>F)  4x</p> <p>G)  4x</p> </div> <div style="text-align: right; margin-top: 20px;"> <p>RD12784-01</p> </div>

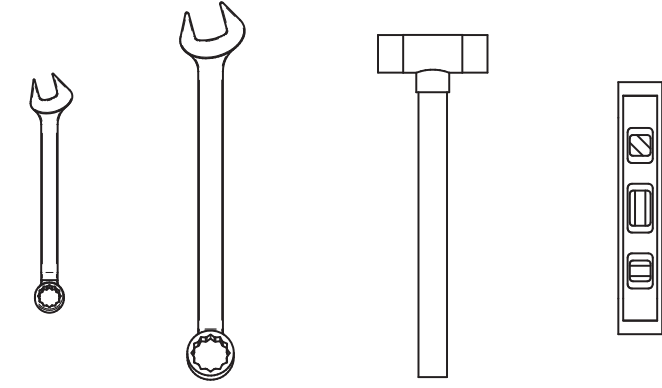
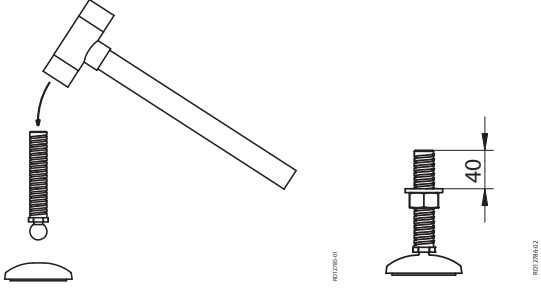
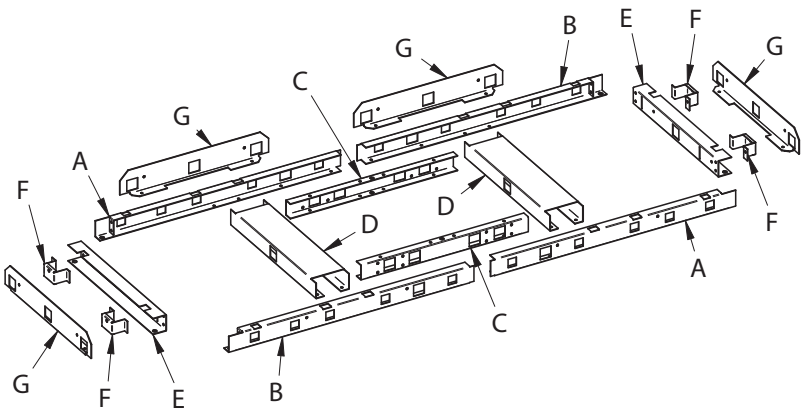
Base assembly	Drawing
<p>The following tools are required:</p>	 <p>2x17mm 2x30mm</p> <p style="text-align: right;">RD12781-01</p>
<p>Assemble the base levelling bolts, by tapping the threaded bar securely into the foot. Screw a nut onto the threaded bar and put a washer on.</p>	 <p style="text-align: right;">RD12781-01</p>
<p>Lay the base parts on the floor as shown in the illustration.</p>	 <p style="text-align: right;">RD12781-01</p>

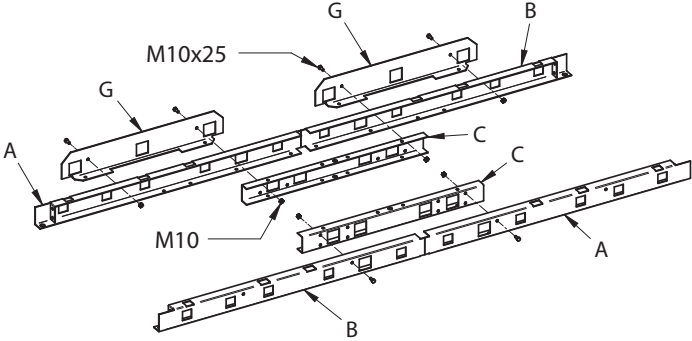
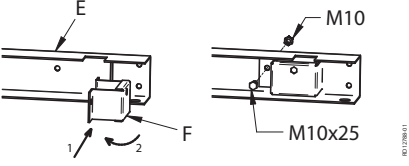
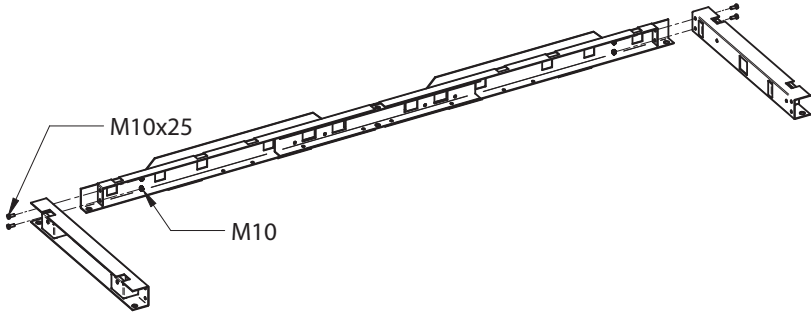
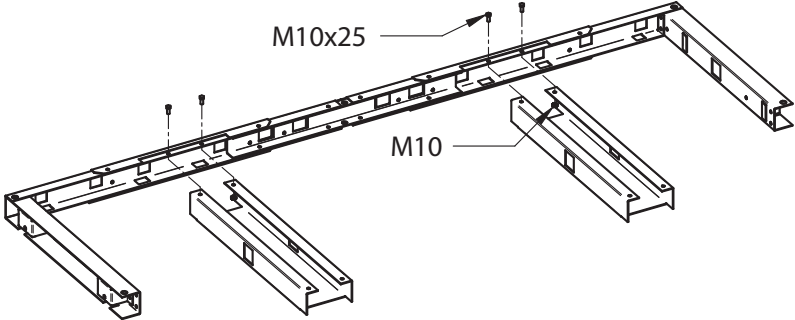
Base assembly	Drawing
<p>Assemble the long pieces:</p> <ul style="list-style-type: none"> • Front long piece: Join A, B and C with nuts and bolts. • Rear long piece: Join A, B, C and G with bolts and nuts. 	
<p>Fit the two small tension fittings (F) on each side of the short members (G) and secure firmly using nuts and bolts.</p>	
<p>Firmly screw the two short members (G) to one of the long pieces using nuts and bolts.</p>	
<p>Turn the base top-side-down and screw the spacers on using nuts and bolts (M10).</p>	

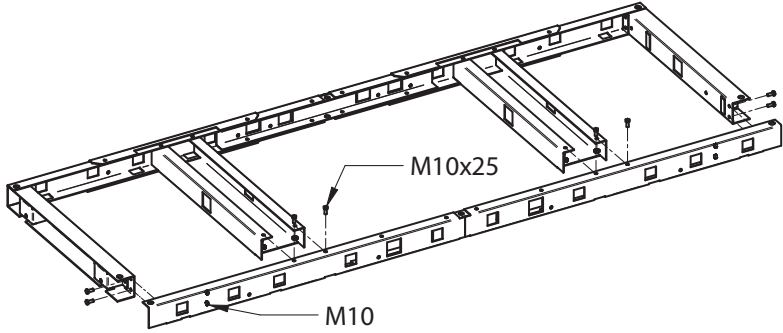
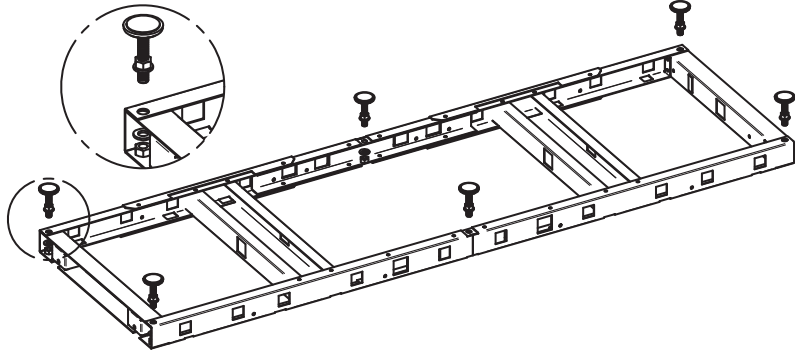
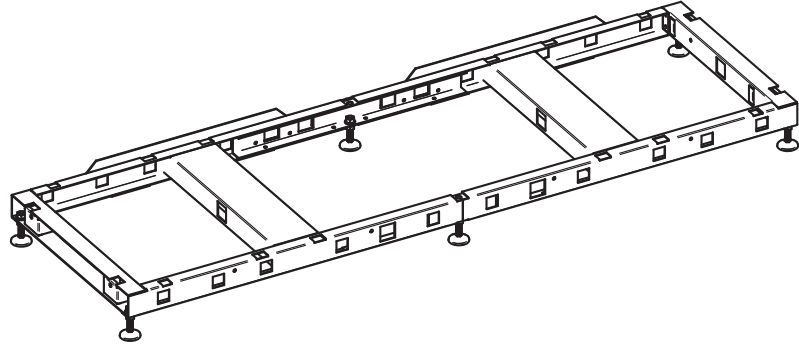
Base assembly	Drawing
<p>Screw the last long piece on using nuts and bolts.</p>	 <p>M10x25</p> <p>M10</p> <p style="text-align: right;">RD12794-01</p>
<p>Screw the levelling bolts on the base with M20 nuts and washers</p>	 <p style="text-align: right;">RD12792-01</p>
<p>Turn the base with legs down and place it so that the tension fittings face away from the operating side</p>	 <p style="text-align: right;">RD12795-01</p>



It is important that the base is levelled before the VEX unit is placed on the base. Adjust the levelling bolts, so that the base is horizontal.

NB

It is best to fit a condensation pipe to the base before the sections are pushed into position. See section "Condensation outlet".

Step 2, VEX sections Manoeuvre the sections onto the base by pushing them directly from the pallet onto the base.

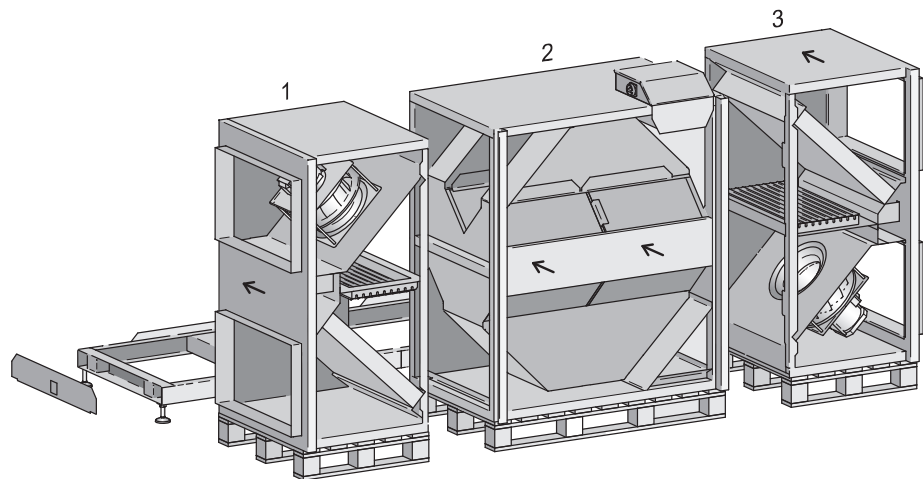

RD12816-01

1. Firstly, push a fan section onto the base.
2. Secondly, push the exchanger section onto the base
3. Lastly, push the last fan section onto the base.

Step 3, Assembly panels and fittings

When all three sections are on the base:

1. Tighten the two assembly panels against the VEX unit using the four bolts (M10 x 35)
2. Close the four fittings on the top of the VEX unit (2).

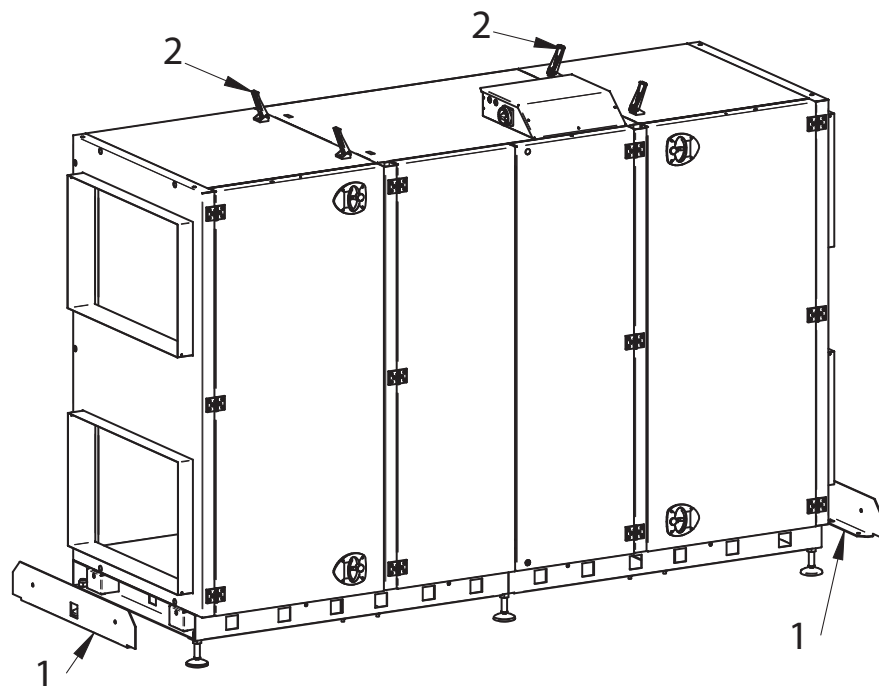

RD12754-01

Step 4, Smooth joints at the condensation tray

To ensure joints are sealed at the condensation tray, the transition between the bottom motor and the condensation tray must be sealed:

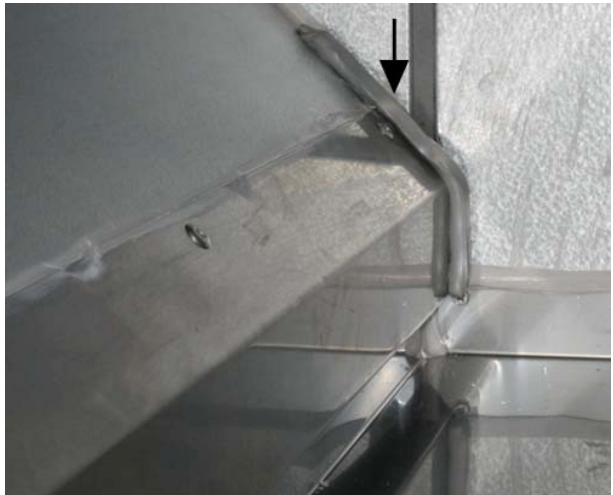
Action	
Smooth the two joints (front and rear on the transition) with a finger. (The arrow shows the rear joint)	

3.2 Condensation drain

3.2.1 Condensation outlet

Connection

The condensation from the unit is collected and directed under the VEX. The condensation outlet can run out from the base as shown in the drawing below.

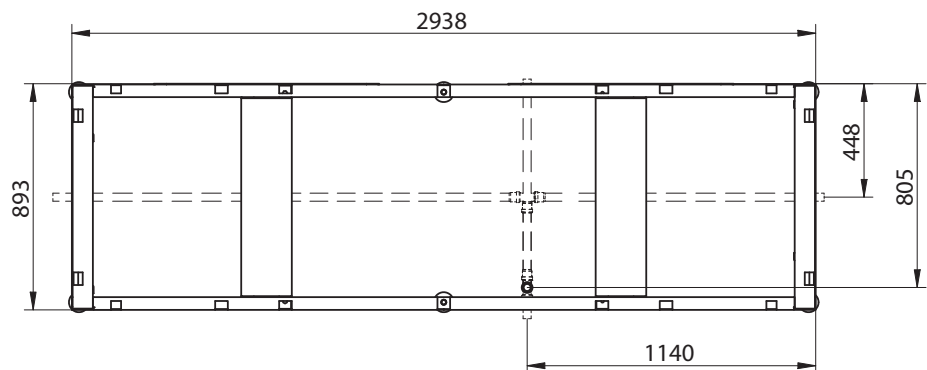

RD12814-01



Drain the condensation outlet into a floor gully or similar. The condensation outlet must be fitted with a water trap. See below.

Risk of frost



Where there is a risk of frost: Insulate the condensation outlet and protect it against frost - if necessary, using a heating cable. Both the condensation pipe under the VEX unit and the condensation outlet need insulating.

Water trap

See the correct dimensions for the water trap on the drawing below.

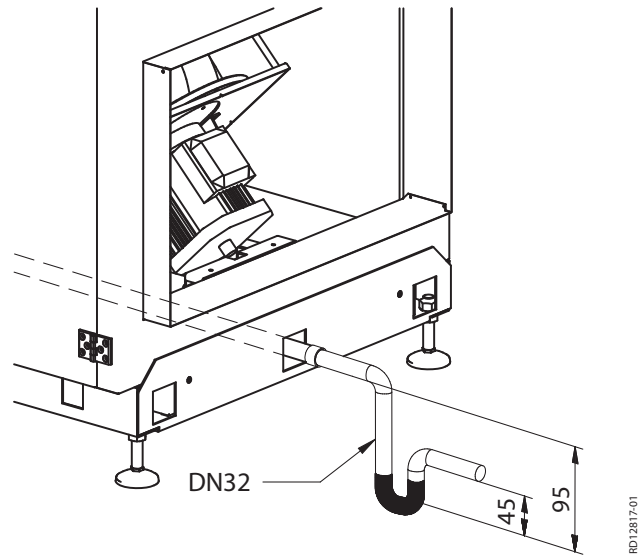



4. Electrical installation

4.1 Electrical installation

See the attached instructions “Electrical Installation Guide of VEX350H-VEX360H-370H with EXact2 control system”.

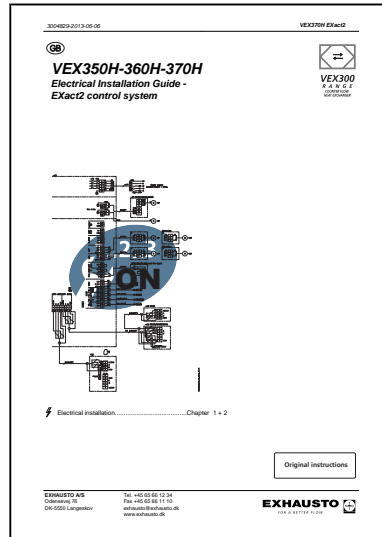



5. Maintenance

5.1 Operating readings via the HMI panel

HMI panel Refer to the "EXact Basic Instructions for the VEX320-330-340-350-360-370" for instructions on accessing Menu 2 "Operating readings" via the technician menu (access code 1111) to check the unit's operating status.

5.2 Maintenance Schedule

Recommended intervals The following chart details the recommended maintenance intervals, under normal operating conditions. EXHAUSTO recommends maintenance is adjusted to suit the actual operating requirements.

Component	Procedure	Once a year	Twice a year
Compact/bag filters*	Change when the display shows the filter alarm.. Recommended that both filters are replaced at the same time. NB: The control system can issue a warning when the filter is becoming soiled.		
	The filter should be changed at least		X
Filter monitor	Check that all the seals in the filter monitor are tight.	X	
Seals and sealing strips	Check that all the seals are tight.	X	
Fans	<ul style="list-style-type: none"> Check that the fan impeller is securely fixed to the shaft. Removal of fan unit. See section "Internal transport with reduced weight" Cleaning. See section "Servicing and cleaning" 	X	
Heating coil/cold water coil (accessory)	Cleaning. See section "Servicing and cleaning"	X	
Counterflow heat exchanger	Cleaning. See section "Servicing and cleaning"	X	
Checking the safety functions	Check: <ul style="list-style-type: none"> Fire thermostats Temperature sensors on heating pipe (accessories) 	X	
Closing damper	Function check	X	
Motor valve and circulation pump (accessories)	Function check	X	

As and when required Following parts are cleaned as and when required

Component	As and when required
Condensation tray	Cleaning and inspection of outlet and water trap
Counterflow heat exchanger	Cleaning. See next sections.

***Filters****Only use original filters**

- The provided filter data and pressure loss graphs (section "Technical data") are based on the use of original filters
- EUROVENT certification is only valid if original filters are used
- Use of non-original filters may cause leakage in the VEX and impair filter function
- EXHAUSTO recommends that you register the filter replacement date to ensure filters are replaced at the correct intervals

5.3 Hygiene

VDI6022 air hygiene standard

To ensure that the VEX300 meets the requirements of the VDI 6022 hygiene standard, its design ensures that:

- bacterial growth and dirt accumulation are minimal
- conditions for cleaning are optimum

Filter F7

The outdoor air side of the unit must be fitted with a F7 filter to meet VDI 6022 requirements.

5.4 Service

5.4.1 Filter change

Disconnect power at the isolation switch before opening the door.

Pull the filters out. Remember to check the flow direction - see the arrows on the filter. Discarded filters must be stored immediately in sealed plastic bags and disposed of responsibly.

Filter change in menu 8.1

After filter change (timer operation only): Go to menu 8.1 in the EXact control system and select "Yes" next to filter change to reset the operating days counter.

Removing the counter flow heat exchangers

Disconnect power at the isolation switch before opening the door.





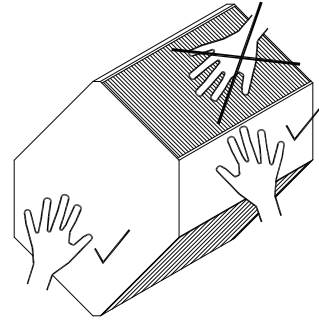



The counter flow heat exchanger fins can be easily damaged - avoid contact with the fins.

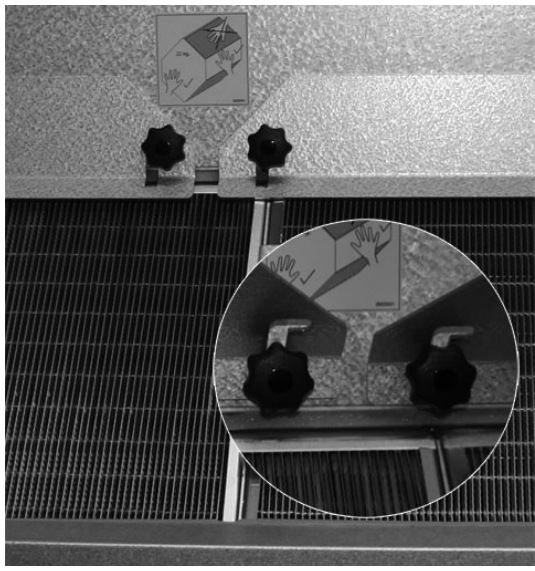

How to remove the counter flow heat exchangers

The following text describes how to remove the four counter flow heat exchangers.

Step		Action
1		<ul style="list-style-type: none"> ● In wall fan section, on panel facing exchanger section: turn the tensioner clockwise 7 times.
2		<ul style="list-style-type: none"> ● In exchanger section: Lift off the centre piece.
3		<ul style="list-style-type: none"> ● Loosen the finger screws on the bracket holding the counter flow exchanger. ● Slide the bracket to one side and down (follow the channel in the bracket). ● In the circle you can see how the bracket is located in the groove when released.

Step		Action
4		<ul style="list-style-type: none"> Remove the panel by pulling on the handle.
5		<ul style="list-style-type: none"> Lift out the right-hand heat exchanger. Lift out the left-hand heat exchanger. <p>NB: A single counter flow heat exchanger weighs 19 kg.</p>
6		<p>The rear exchangers can now be removed.</p> <ul style="list-style-type: none"> Turn the tensioner clockwise 7 times (See step 1)
7		<ul style="list-style-type: none"> Lift out the centre piece Repeat points 3-4-5

Refitting the counter flow heat exchangers

The following describes how to refit the counter flow heat exchangers and it refers directly to the above instructions for removing the heat exchangers.

Step	Action
1	<ul style="list-style-type: none"> Set the rear exchangers in place. Push the handle into place (step 4). Release the finger screws, insert the bracket and screw in the finger screws without tightening them (step 3).
2	<ul style="list-style-type: none"> Turn the rear tensioner anticlockwise 7 times (step 1). Tighten the finger screws. Refit the front panel (step 7).
3	<ul style="list-style-type: none"> Repeat steps 1 and 2 for the front exchangers.

5.4.2 Servicing and cleaning

Cleaning the counter flow heat exchanger:

- Clean the exchanger by flushing with hot water
- Water temperature max. 90°C.

How to clean the fan

See section "Internal transport with reduced weight" for details on how to remove the fan units.

Step	Action
1	Switch off the power supply to the unit at the isolation switch
2	Clean the fan impellers with a vacuum cleaner and by wiping with a damp cloth NB: Clean the impellers carefully to avoid disturbing the balance
3	Once re-fitted, check the unit operates without vibrating

Cleaning cold water coil/heating coil

Step	Action
1	Switch off the power supply to the unit at the isolation switch
2	Vacuum clean the heating coil
3	Cold water coil: clean the condensation tray



6. Technical data

6.1 Weight, corrosion class, temperature ranges

Weight

Weight	702 kg
--------	--------

Corrosion class

Corrosion class	Corrosion class C4 in accordance with EN ISO 12944-2
-----------------	--

Temperature ranges

Outdoor air temperature	-40°C to +35°C
Ambient temperature	-30°C to +50°C

At temperatures below -25°C (with outdoor installation), use of a thermostatically controlled heater in automated control box is recommended.

HMI-panel

Ingress protection	IP20
Ambient temperature	0°C - +50°C

At temperatures below 0°C the display may react more slowly than usual.

Fire thermostats

Cut-out temperature, BT70	70°C
Cut-out temperature, BT50	50°C
Cut-out temperature, BT40	40°C
Max. ambient temperature, sensor	250°C
Ambient temperature, thermostat housing	0°C - +80°C
Sensor length	125 mm
Ingress protection	IP40

Motor damper

Motor damper type	LS500x80024	LSR500x80024
Designation	LSA/LSF	LSFR
Motor type	NM24-F	AF-24
Rotation time	75–150 s	open: 150 s close: 16 s
Ingress protection	IP42	IP42
Ambient temperature	-20°C to +50°C	-30°C to +50°C
Damper depth (LS rail system)	115 mm	115 mm
Damper depth (METU rail system)	150 mm	150 mm

A maximum of two LSFR dampers or four LSA/LSF dampers may be connected.

6.2 Compact filters

Pressure loss curves for M5 and F7 filters

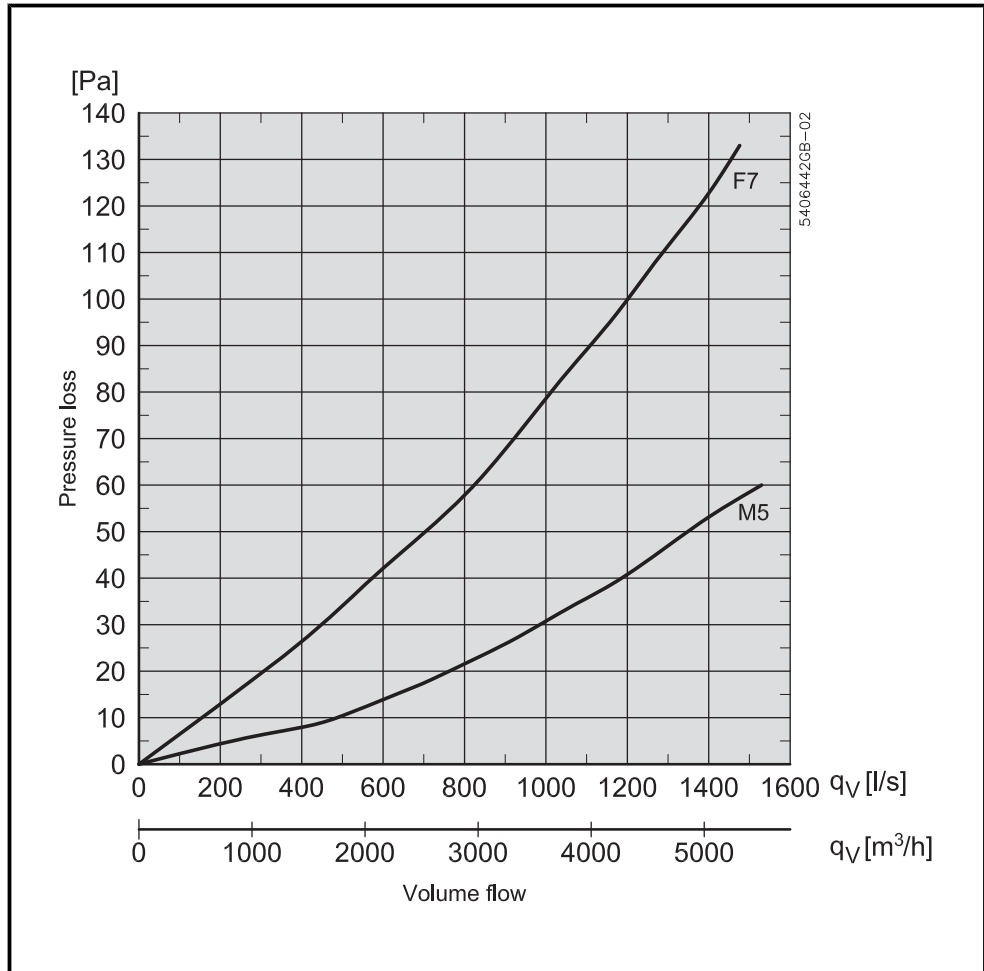

Filter data	M5	F7
Filter panel h x b (qty. 2 per air direction)	414 x 750 mm	414 x 750 mm
Panel filter thickness	96	96
Efficiency	45 %	85 %
Recommended difference between final pressure drop and initial pressure drop	+100 Pa	+100 Pa



EUROVENT certification is only valid if original filters are used. For more details about original filters, see section "Maintenance".

6.3 Bag filters

Pressure loss curves for M5 and F7 filters

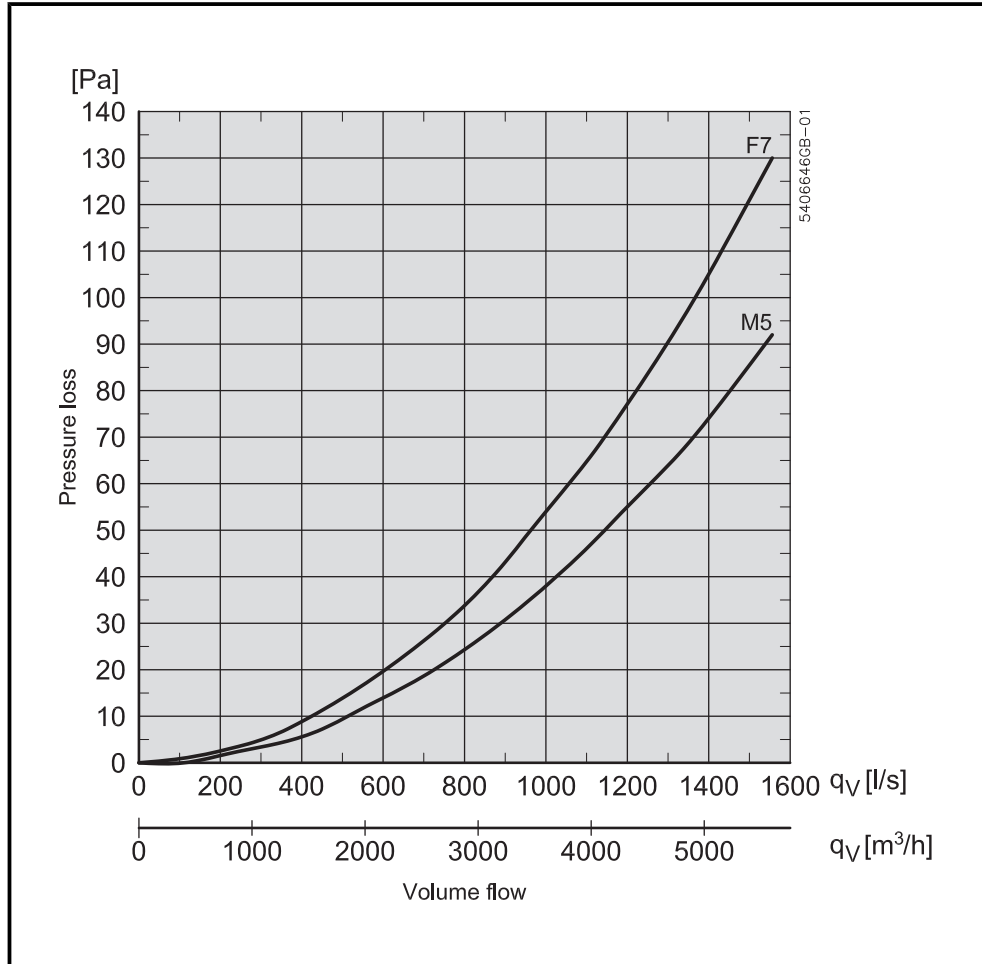

Filter data	M5	F7
Filter area h x b (qty. 2 per air direction)	1 x 592 x 490mm 1 x 592 x 287mm	1 x 592 x 490mm 1 x 592 x 287mm
Total number bags x depth	5 x 520mm 3 x 520mm	8 x 520mm 5 x 520mm
Volume flow rate	5000 m3/h	5000 m3/h
Initial pressure drop	58 Pa	86 Pa
Recommended difference between final pressure drop and initial pressure drop	+100 Pa	+100 Pa



EUROVENT certification is only valid if original filters are used. For more details about original filters, see section "Maintenance".

6.4 Capacity diagram

6.4.1 Capacity diagram, ventilation with heat recovery

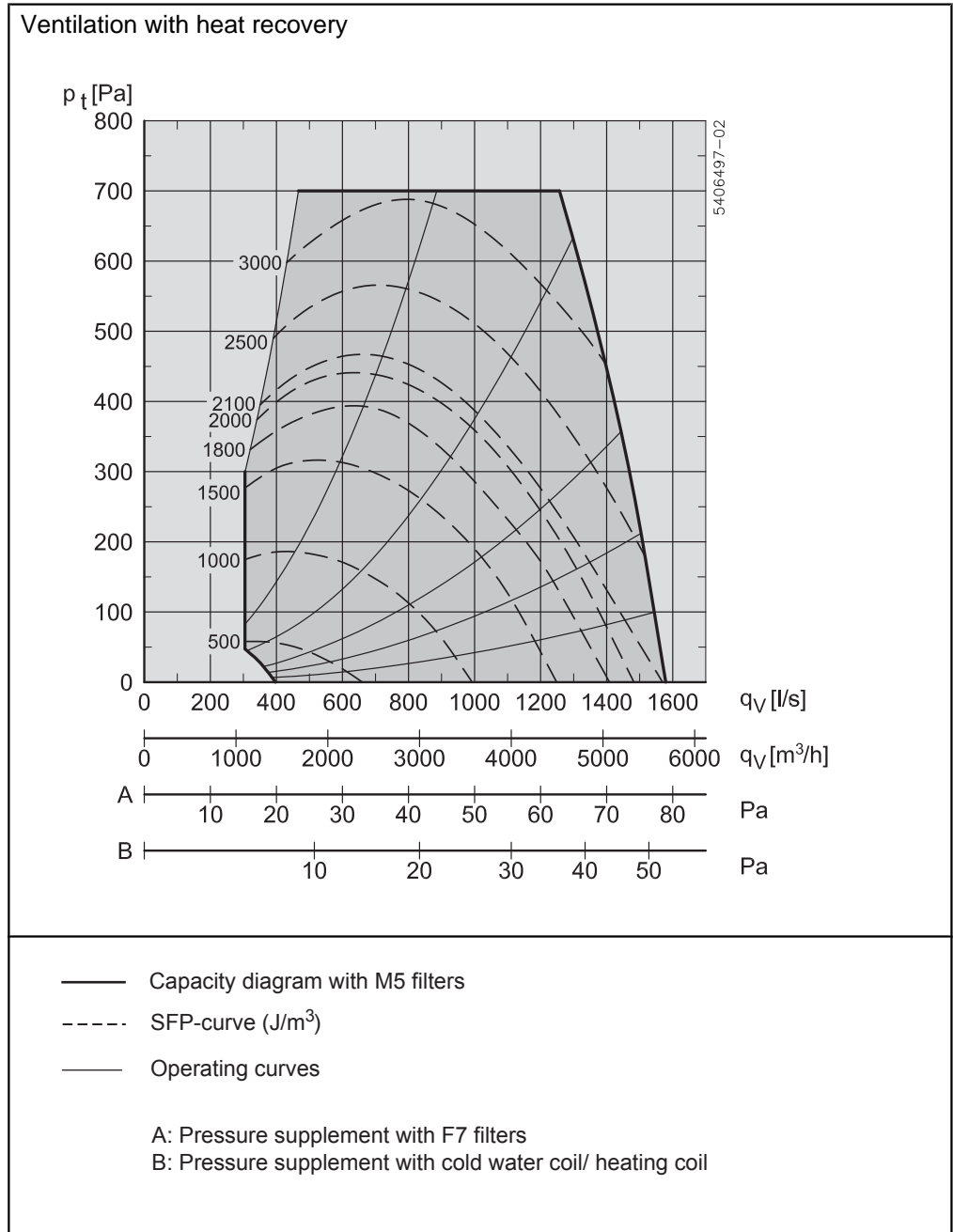

6.4.2 Capacity diagram, ventilation with bypass operation

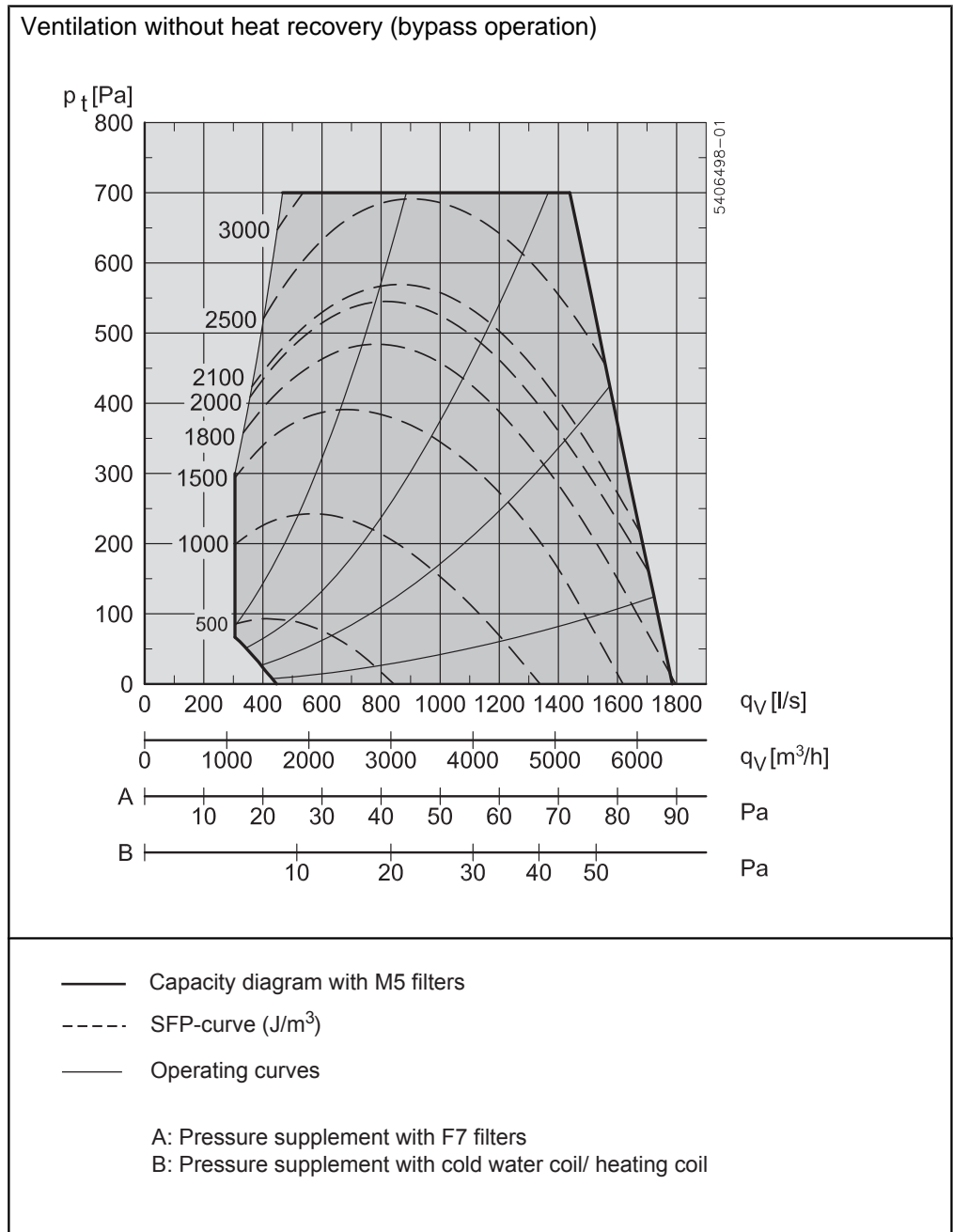

6.5 Ordering spare parts

Find production number

When ordering spares, please state the relevant production part number. This will ensure that the correct parts are delivered. The production number is given on the front of the VEX guidelines and on the VEX rating plate.

Contact:

Contact your local EXHAUSTO office service department to order a spare part. Contact information is given on the back cover of these instructions. See also the "Layout" section for an overview of the position and designation of parts in the VEX.



Scan code and go to addresses at
www.exhausto.com