

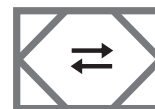

VEX370HX

Mechanical guidelines For third party control system



VEX300
R A N G E
COUNTER FLOW
HEAT EXCHANGER







Unit supplied with (factory fitted):

- Bag filter, FB
- M5-compact filter, FP
- F7-compact filter, FP
- OD - roof for outdoor
- Mounting base, (unassembled)
- Motor controller
- HCW370I - Integrated heating coil (water)

The following accessories are supplied separately:

- HCW-heating coil (water), duct-fitted
- Motor valve, MVM _____K_v-value
- Motor valve outdoor, MVM-OD (partially mounted)
- DX cooling/heating coil
- CCW-cold water coil
- Closing damper, LS600x1200, (LSA exhaust)
- Closing damper, LS600x1200, (LSF outdoor)
- Closing damper, LSR600x1200, with spring-return (LSAR exhaust)
- Closing damper, LSR600x1200, with spring-return (LSFR outdoor)
- _____

Serial no.: _____
 Prod.order no.: _____
 Sales order no.: _____

-  Product information..... Chapter 1 + 6
-  Mechanical assembly..... Chapter 2 + 3
-  Electrical installation..... Chapter 4
-  Maintenance..... Chapter 5

Original instructions



1. Product information

1.1. Designations used in these instructions.....	6
Model overview.....	6
1.1.1. Designations used in these instructions.....	7
1.2. Application.....	7
1.3. Location requirements.....	8
1.3.1. Space requirements.....	8
1.3.2. Requirements for underlying surface.....	8
1.3.3. Outlet.....	8
1.3.4. Requirements for duct system.....	9
1.4. Description.....	9
1.4.1. VEX unit construction.....	9
1.5. Main aim.....	11
1.5.1. Dimensional drawing.....	11



2. Handling

2.1. Unpacking.....	13
2.2. Transport.....	13
2.2.1. Passage through openings	13
2.2.2. Internal transport with reduced weight.....	14
2.2.3. Disassembly of integrated heating coil, HCW370I	17



3. Mechanical assembly

3.1. Installing the unit.....	18
3.1.1. Assembly instructions.....	18
3.1.2. Step 1–4.....	19
3.2. Condensation drain.....	24
3.2.1. Establishment of condensation outlet.....	24
3.3. Integrated water heating coil.....	25
3.3.1. Principles for connecting the water heating coil.....	25
3.3.2. MVM valve.....	27



4. Electrical installation

4.1. Electrical installation.....	28
--	-----------



5. Maintenance

5.1. Maintenance Schedule.....	29
5.2. Hygiene.....	30
5.3. Service.....	30
5.3.1. Filter change.....	30
5.3.2. Removing the counter flow heat exchangers.....	30
5.3.3. Servicing and cleaning.....	33
5.4. Airflow measurement.....	34
5.4.1. Determining airflow and pressure.....	34



6. Technical data

6.1. Weight, corrosion class, temperature ranges, etc.....	37
6.2. Compact filters.....	38

6.3. Bag filters.....	39
6.4. Integrated water heating coil HCWi.....	39
6.4.1. MVM motor valve	40
6.5. Capacity diagram.....	41
6.5.1. Capacity diagram, ventilation with heat recovery.....	41
6.5.2. Capacity diagram, ventilation with bypass operation.....	42
6.6. Ordering spare parts.....	42

Symbols, terms and warnings

Prohibition symbol



Failure to observe instructions marked with a prohibition symbol may result in serious or fatal injury.

Danger symbol



Failure to observe instructions marked with a danger symbol may result in personal injury and/or damage to the unit.

Scope

This instruction manual is for use with EXHAUSTO VEX-type air handling units. Please refer to the product instructions regarding accessories and extra equipment.

The instructions must be fully observed to ensure personal safety and to protect the equipment and ensure its correct operation. EXHAUSTO A/S accepts no liability for accidents caused by equipment not used in accordance with the manual's instructions and recommendations.

Supply air/extract air

These instructions use the following terms as given in DS447-2013:

- Supply air (air blown in)
- Extract air (air removed)
- Outdoor air
- Exhaust air

Left/Right

The term R for Right, indicates the supply air is to the right of the cooling unit, as seen from the operating side. The term L for Left, indicates the supply air is to the left.

Front page: Accessories

The front page of the instruction manual contains a checklist, detailing the accessories delivered with the VEX unit.

NB

When retrofitting EXHAUSTO accessories, please update the checklist on the front page.

Warnings

No duct connection



If one or more of the spigots is not connected to a duct: Fit a protective net to the spigots with a maximum mesh width of 20 mm (in accordance with EN294).

Lock the air handling unit during operation

The VEX unit must always be locked during operation:

- Use the cylinder lock in the handle. **Remember** to remove the key from the lock.
- Or use a padlock. Use the handle's built-in padlock fixture.

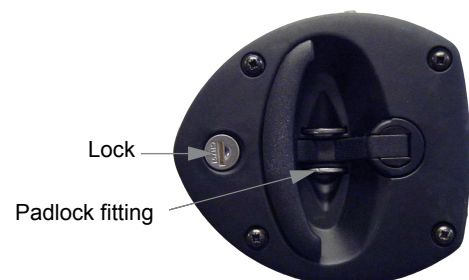

Rating plate

The VEX unit rating plate shows:

- VEX model (1)
- Production order no. (2)

Type	V370HLEC2	← Icu = 10kA	1
	No./Year 9999999/2013	←	2
Supply	Voltage: 3x400V+N+PE ~50Hz	Current: 17,5A	
ECO design	$\eta = 60,4\%$ (A) N62 (2015) N = 66,5 VSD integrated		

NB





Always have the production number ready when contacting EXHAUSTO A/S.



1. Product information

1.1 Designations used in these instructions

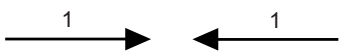
Model overview

Elements	Explanation
	Fan
	Compact filter
	Bag filter
1,1,A or B	Extract air spigot NB: In cases where the unit has two spigots (extract air/flue gases), the filter is always located by the extract air spigot
1,2,A	Exhaust air spigot
2,1,A	Outdoor air spigot
2,2,A or B	Supply air spigot
	Air direction, extract air
	Air direction, supply air

NB The sketch shows compact filters

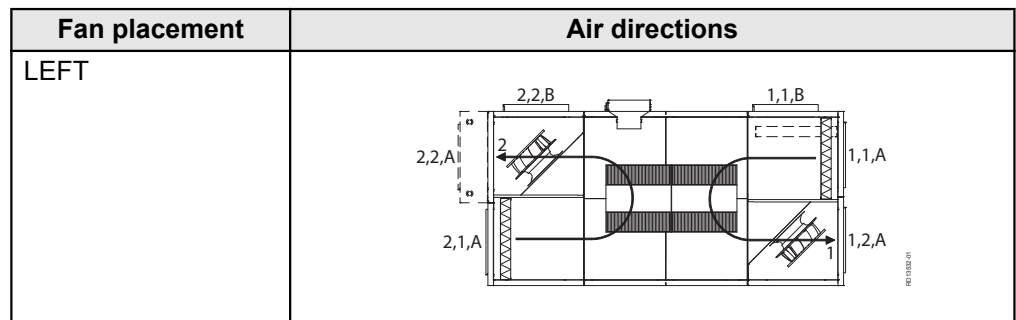

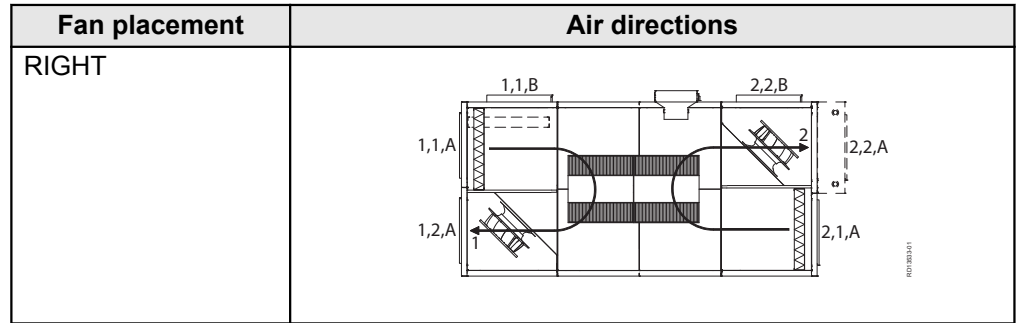

NB Spigot location B option not available with outdoor models.

1.1.1 Designations used in these instructions

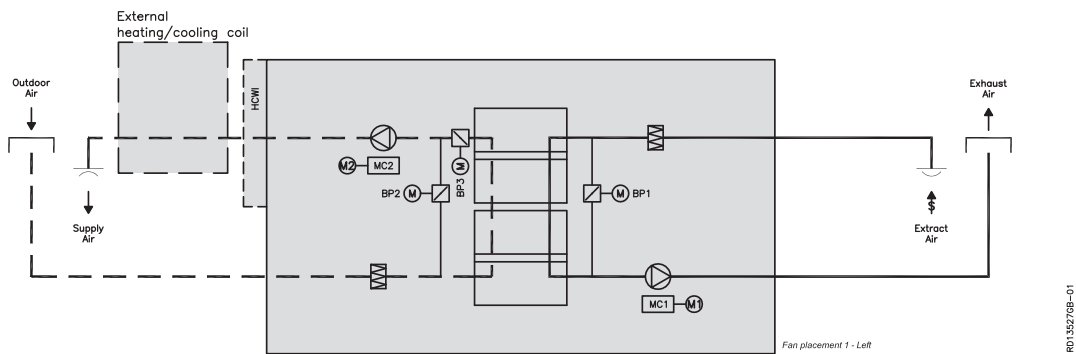

The simplified diagram shows a VEX unit with LEFT fan placement.

Component	Function
BP1	Bypass damper with motor (extract air - exhaust air)
BP2 + BP 3	Bypass damper with motor (outdoor air - supply air)
HWCi	Integrated water heating coil
MC1	Motor control, motor 1 (exhaust air)
MC2	Motor control, motor 2 (supply air)
M1	Exhaust motor
M2	Supply air motor

1.2 Application

Comfort ventilation EXHAUSTO VEX is used for comfort ventilation tasks. Operating temperature range for the unit – see section "Technical data".

Prohibited uses The VEX unit is not to be used to transport solid particles or in areas where there is a risk of explosive gases.

1.3 Location requirements

Positioning

The air handling unit is designed for indoor fitting. The air handling unit can be ordered for outdoor installation (accessory Outdoor, OD).

1.3.1 Space requirements

The drawing below indicates how much space is required to open the side-mounted doors for servicing, replacing filters, cleaning, etc. The drawing shows compact filters.

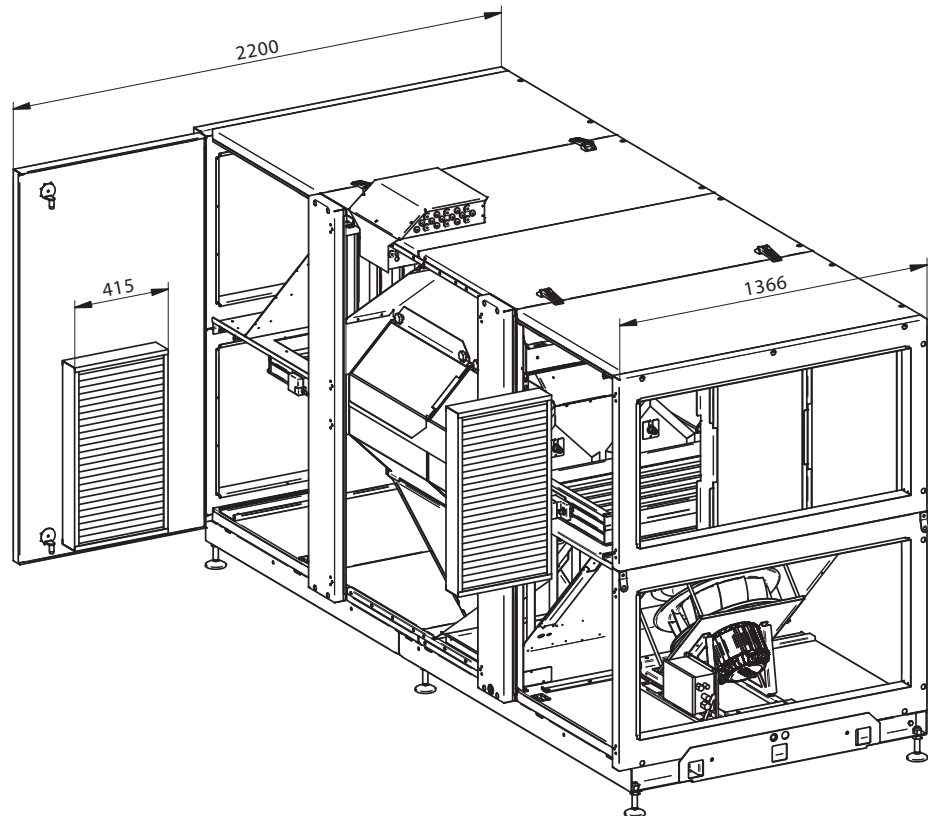

RD13499-01

NB

For servicing purposes, a free height of at least 200 mm is required above the unit's connection box.

1.3.2 Requirements for underlying surface

When floor-mounting the unit, the surface must be:

- level (+/- 10 mm per metre)
- hard
- resistant to vibration

The VEX unit leg height can be adjusted: 55–110 mm.

1.3.3 Outlet

A condensation outlet must be installed in the immediate vicinity of the unit. See also "Mechanical fitting" section.

1.3.4 Requirements for duct system

Silencers The duct system must be fitted with silencers specified by the Project Manager, which meet the requirements of the operating area.

Bends A duct bend may be fitted immediately after the unit, because the airflow in the spigot has a uniformly moderate speed profile, which results in negligible system pressure loss.

Insulation  **The duct system must be insulated against:**

- condensation
- sound leakage
- heating/cooling losses

Condensation Condensation in the ducts may occur when the exhaust/outdoor air has high humidity. EXHAUSTO recommends a condensation outlet is also fitted at the lowest point in the ducts.

No duct connection  **If one or more of the spigots is not connected to a duct: Fit a protective net to the spigots with a maximum mesh width of 20 mm.**

1.4 Description

1.4.1 VEX unit construction

Layout drawing, Left model The drawing below illustrates the construction of the unit, without doors: The drawing shows compact filters.

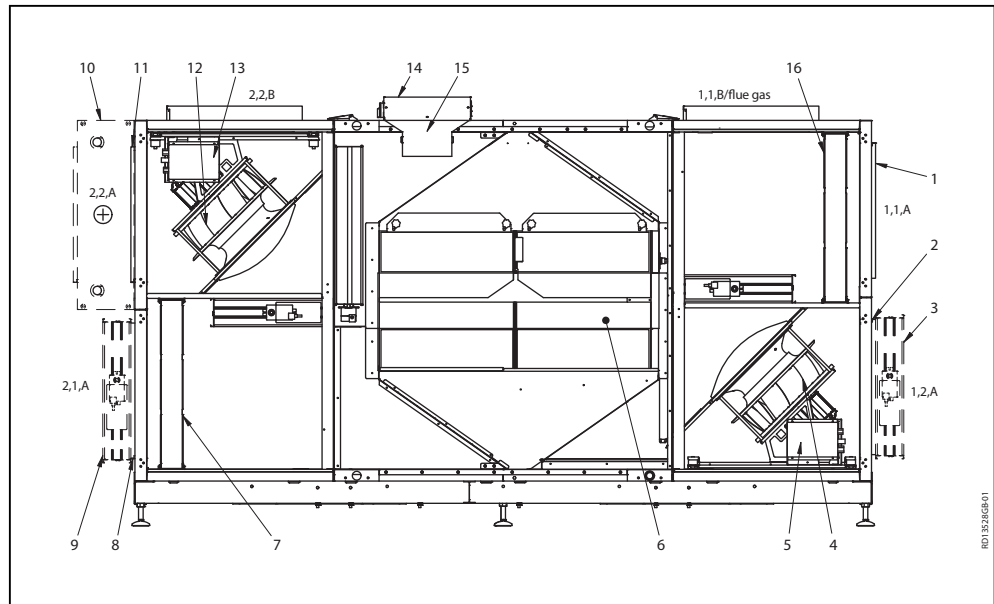

Layout drawing, Right model

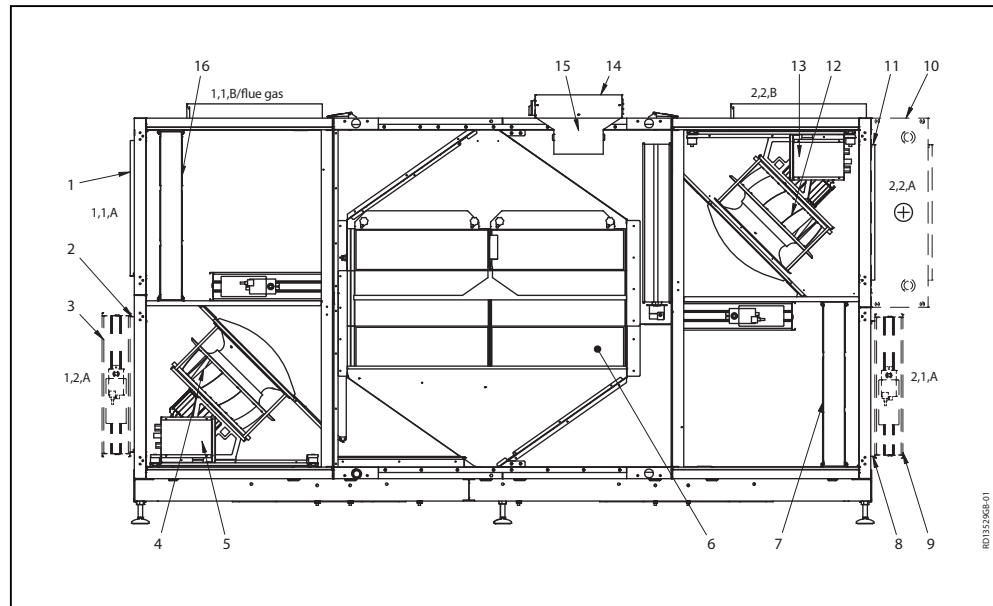

Pos. no.	Part	Function
1	Spigot 1,1,A	Extract air spigot The spigot can also be positioned on the top of the unit (1,1,B). Does not apply to units designed for outdoor fitting
2	Spigot 1,2,A	Exhaust air spigot
3	Closing damper LS	Closing damper, exhaust air, LSA (accessory).
4	Fan unit, exhaust air	Removes "stale" air
5	Motor control, extract air fan	Variably adjusts fan
6	Counterflow heat exchanger	Six aluminium counter flow heat exchangers
7	Outdoor air filter	Filters outdoor air
8	Spigot 2,1,A	Outdoor air spigot
9	Closing damper LS	Closing damper, outdoor air, LSF (accessory).
10	Heating coil	Integrated heating coil Heats supply air if heat recovery is insufficient (accessory).
11	Spigot 2,2,A	Supply air spigot. The spigot can also be positioned in the top of the unit (2,2,B). Does not apply to units designed for outdoor fitting
12	Fan unit, supply air	Blows air into the room
13	Motor control, extract air fan	Variably adjusts fan
14	Connection box	Connection terminal board
15	Connection box	Cover plate
16	Extract air filter	Filters extract air

Cabinet

The inside and outside of the cabinet is made of Aluzinc® The cabinet is insulated with 50 mm mineral wool.

Fans	The unit contains two centrifugal fans for exhaust air and supply air.
Counter flow heat exchangers	The unit's counterflow heat exchangers are made of aluminium and are highly efficient. The counterflow heat exchangers can be taken out and cleaned. See section "Servicing".
Filters	There are integral panel filters on both the extract air and outdoor air sides.
Bypass design	The unit has a built-in double modulating bypass. In the case of summer operation without heat/cold recovery, both outdoor air and extract air are directed around the heat exchanger to reduce energy consumption.

1.5 Main aim

1.5.1 Dimensional drawing

The sketches show compact filters.

VEX370H, Left

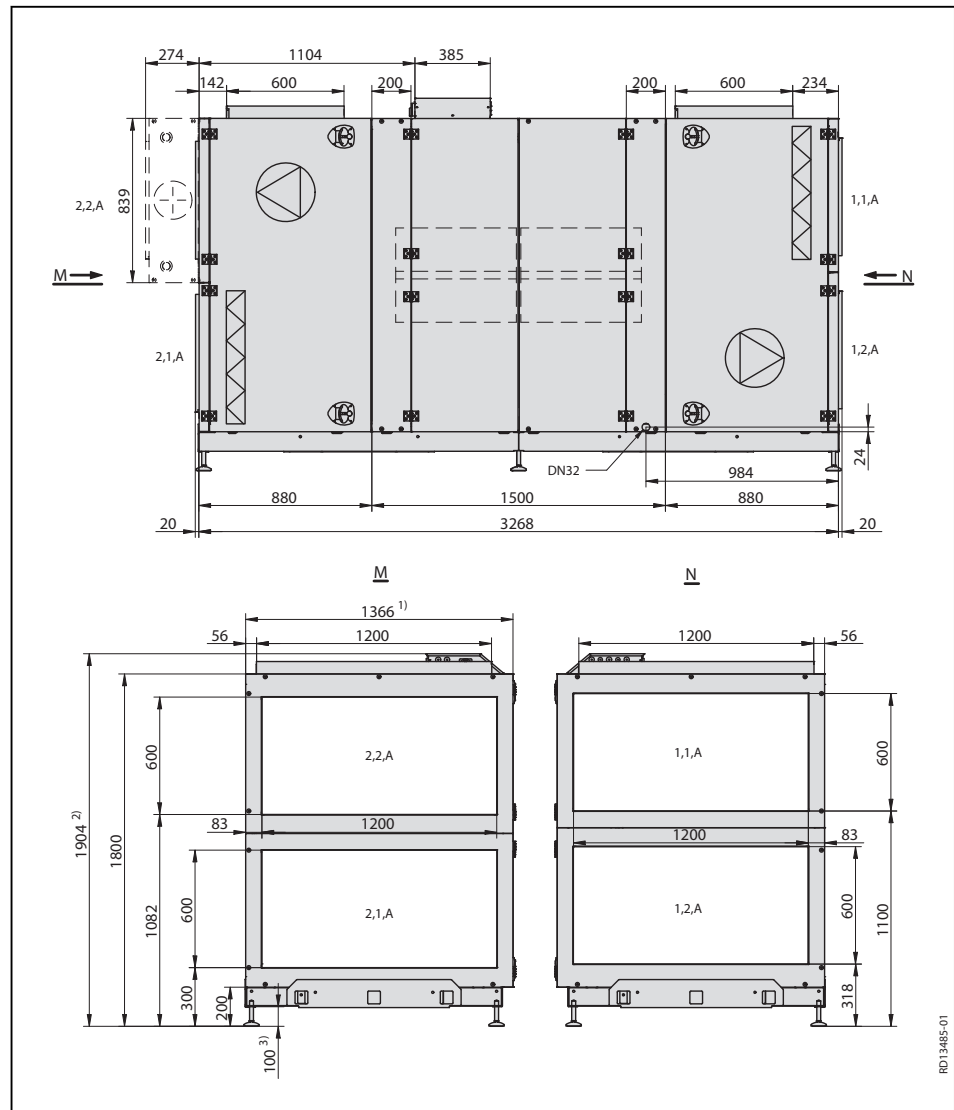

- 1) Allow for space in front of the VEX unit, so the doors can be opened
 - 2) Allow for free height over the VEX unit, so the connection box can be serviced
 - 3) The legs under the VEX unit can be adjusted for height between 55mm and 110mm.
- See "Space Requirements" section.

VEX370C, Right

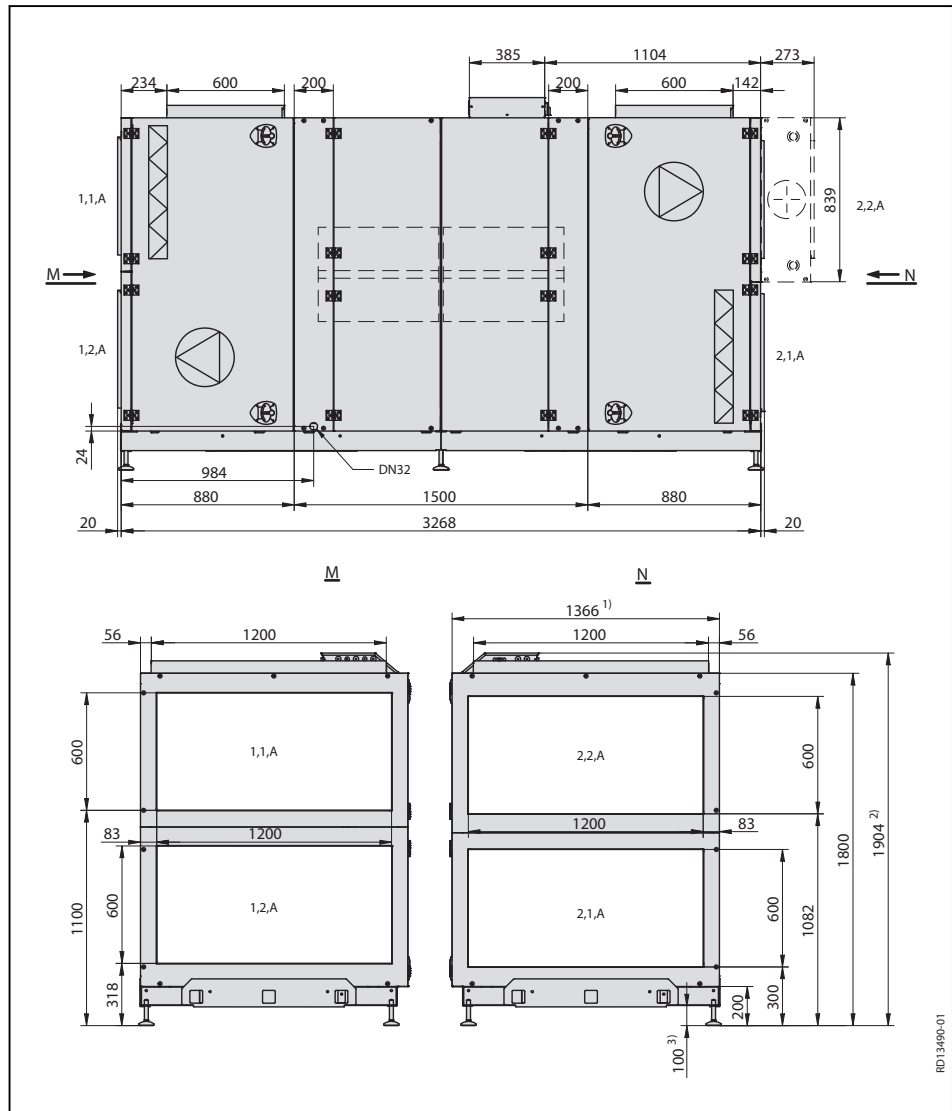

- 1) Allow for space in front of the VEX unit, so the doors can be opened
 - 2) Allow for free height over the VEX unit, so the connection box can be serviced
 - 3) The legs under the VEX unit can be adjusted for height between 55mm and 110mm.
- See "Space Requirements" section.

RD13490-01



2. Handling

2.1 Unpacking

Supplied components

The following components are supplied:

- VEX unit with associated base.
- Supplied accessories (as indicated in the checklist on the front page of the instructions)

Packaging

The unit is delivered in three sections on separate disposable pallets; packed in cardboard and clear plastic. The base is packed in a wooden box.

Unpacking

Depending on the installation site's spatial limitations, unpacking can be done in the following manner:

- Unpack and assemble the base and sections and subsequently transport the VEX unit to the site or
- set up the base at the installation side and mount the sections on the base afterwards.

Base assembly is described in section 3.1.

NB

Once the plastic has been removed, the unit must be protected against dirt and dust:

- **The covers on the spigots must not be removed until the spigots are connected to the ventilation ducts.**
- **Whenever possible, keep the unit closed during fitting.**

The unit should be cleaned before it is used.

Once the VEX unit is fitted, it must be checked and thoroughly cleaned. All dust, debris and metal shavings must be vacuumed up.

2.2 Transport

2.2.1 Passage through openings

The sections' principal dimensions

Measurements are based on the exact dimensions of the VEX unit. The VEX unit is shown with compact filters.

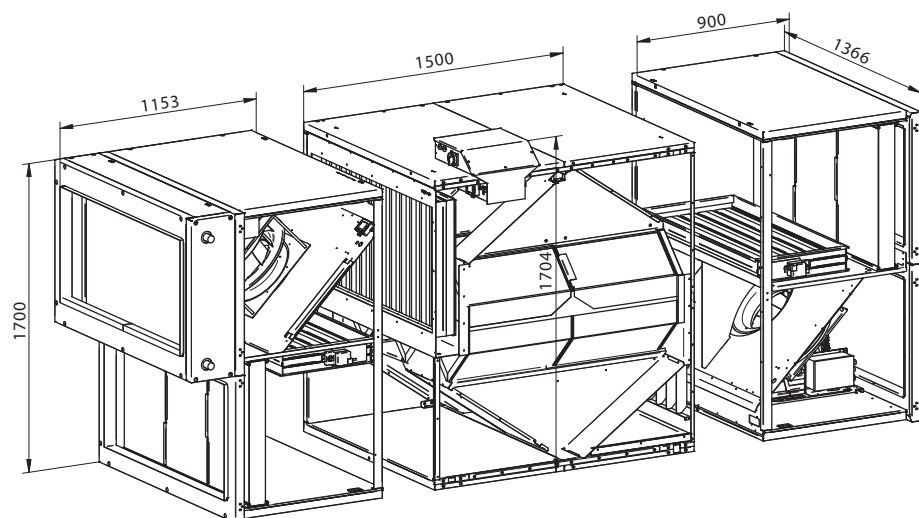

RD13504-01

Width - fan sections The list below shows how large an opening has to be for the fan sections to pass through:

If the opening width is	Then
Less than 900 mm	The unit will not pass through
Between 900 and 1,153 mm	For fan section with integrated heating coil: <ul style="list-style-type: none"> disassemble the integrated heating coil as described in the section "Disassembly of integrated heating coil".
Greater than 1153 mm	The unit can pass through

Width - heat exchanger section The list below shows how large an opening has to be for the heat exchanger section to pass through:

If the opening width is	Then
Less than 1,366 mm	passage is not possible, unless the VEX is constructed and delivered in a split version (agreed at time of order). See separate instructions.
Greater than 1,366 mm	The unit can pass through

VEX370 supplied in split version

VEX370 can be ordered as a SPLIT 1 or SPLIT 2 model:

Model	Conditions
SPLIT 1	<ul style="list-style-type: none"> VEX370 is supplied with normal fan sections, but the heat recovery section can be separated for transport through door openings of 900 x 2000 mm The VEX is assembled and joints sealed on site by the installer in accordance with the supplied instructions
SPLIT 2	<ul style="list-style-type: none"> VEX370 is supplied in assembled state but without joint sealing The VEX is ready for disassembly, transport into the building, reassembly and joint sealing by certified personnel

2.2.2 Internal transport with reduced weight

Weight reduction The weight can be reduced during transport by removing the service doors, fan units and counter flow heat exchanger. The table below shows the how much weight is reduced when the subcomponents are removed.

Section	Subcomponents	Weight
Fan section, 2 x 220 kg		
	Fan section, empty cabinet	150 kg
	Door	24 kg
	Fan unit	40 kg

Section	Subcomponents	Weight
	Compact or bag filters, 3 items of 2 kg weight	6 kg
Exchanger section, 1 x 430 kg		
	Exchanger section, empty cabinet	285 kg
	Counter flow heat exchangers, 6 x 19 kg	114 kg
	Doors, 2 x 15.5 kg	31 kg
Integrated heating coil HCWI, 58 kg		
Base, 1 x 90 kg		
Total weight VEX370 unit		1018 kg

Removing the service doors

To remove the service doors:

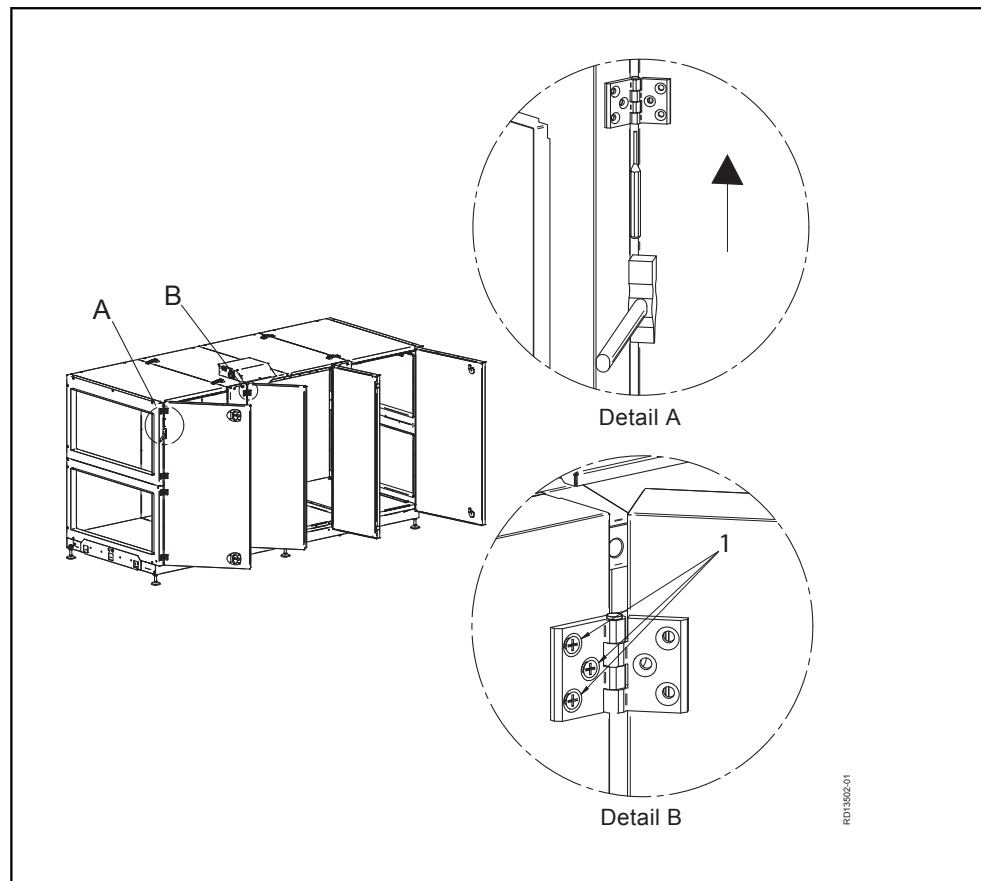

- A**
- How to remove the doors (2 in no.) to the fan sections:
- Open the door
 - Tap the hinge door pin out from below using a small pin bolt or similar
 - Lift the door off (**Note - weight 23.5 kg**).

B	<p>How to remove the doors (2 in no.) to the heat exchanger sections:</p> <ul style="list-style-type: none"> • Open the door • Unscrew the door hinge from the front panel (1) and take the door off.
----------	---

To remove the fan unit

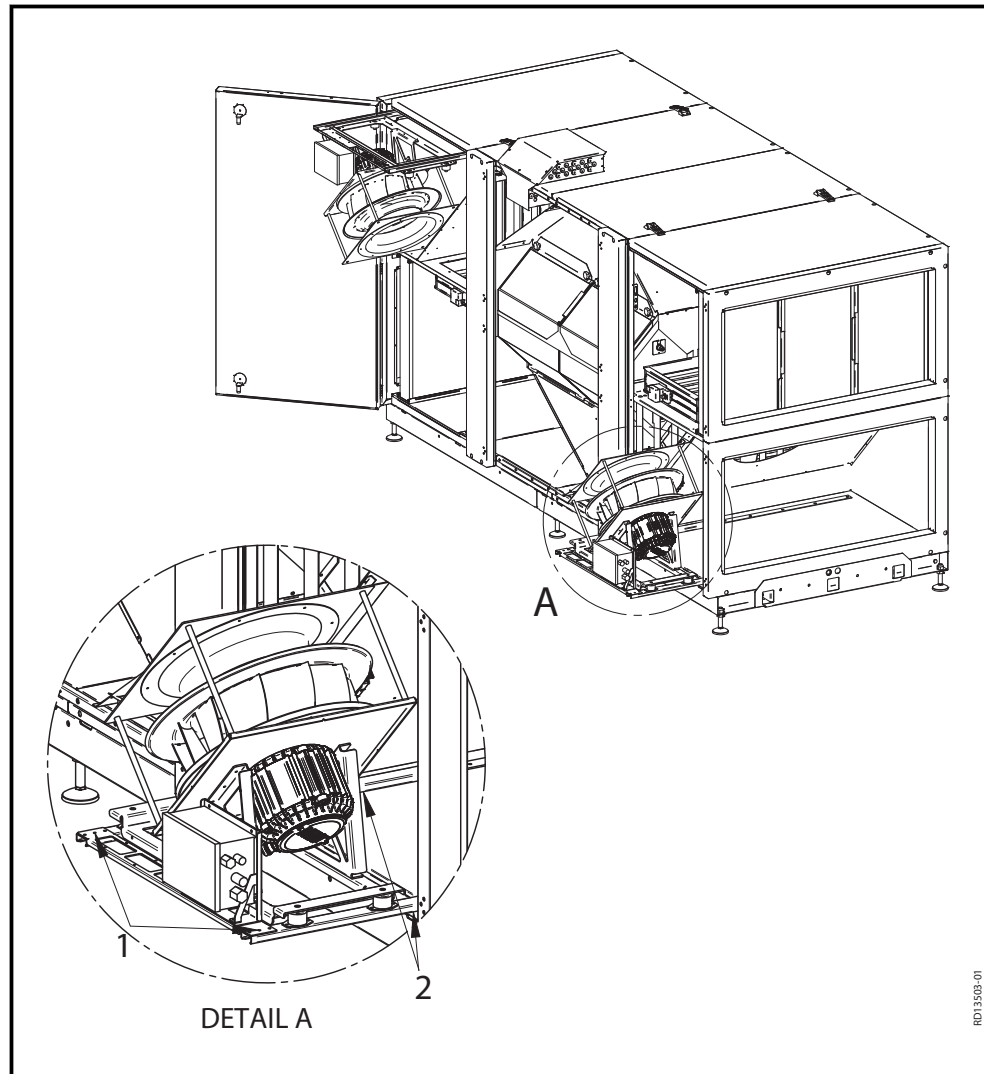

Step	Action
1	Remove the fixing screws (1) on the sliding rail (out towards the operating side)
2	Cut the cable ties holding the motor cable and the cable ties holding the measuring hose
3	Pull the fan unit out to the end-stop (a screw on each rail acts as a stop)
4	Remove the supply cable and the control cable in the motor control.
5	Remove the two end-stops (screws one on the sliding rail (2)). The fan unit can now be lifted off.
<p>NB: A single fan unit weighs 40 kg.</p>	

RD13503-01

Removing the counter flow heat exchangers See section "Servicing"

2.2.3 Disassembly of integrated heating coil, HCW370I

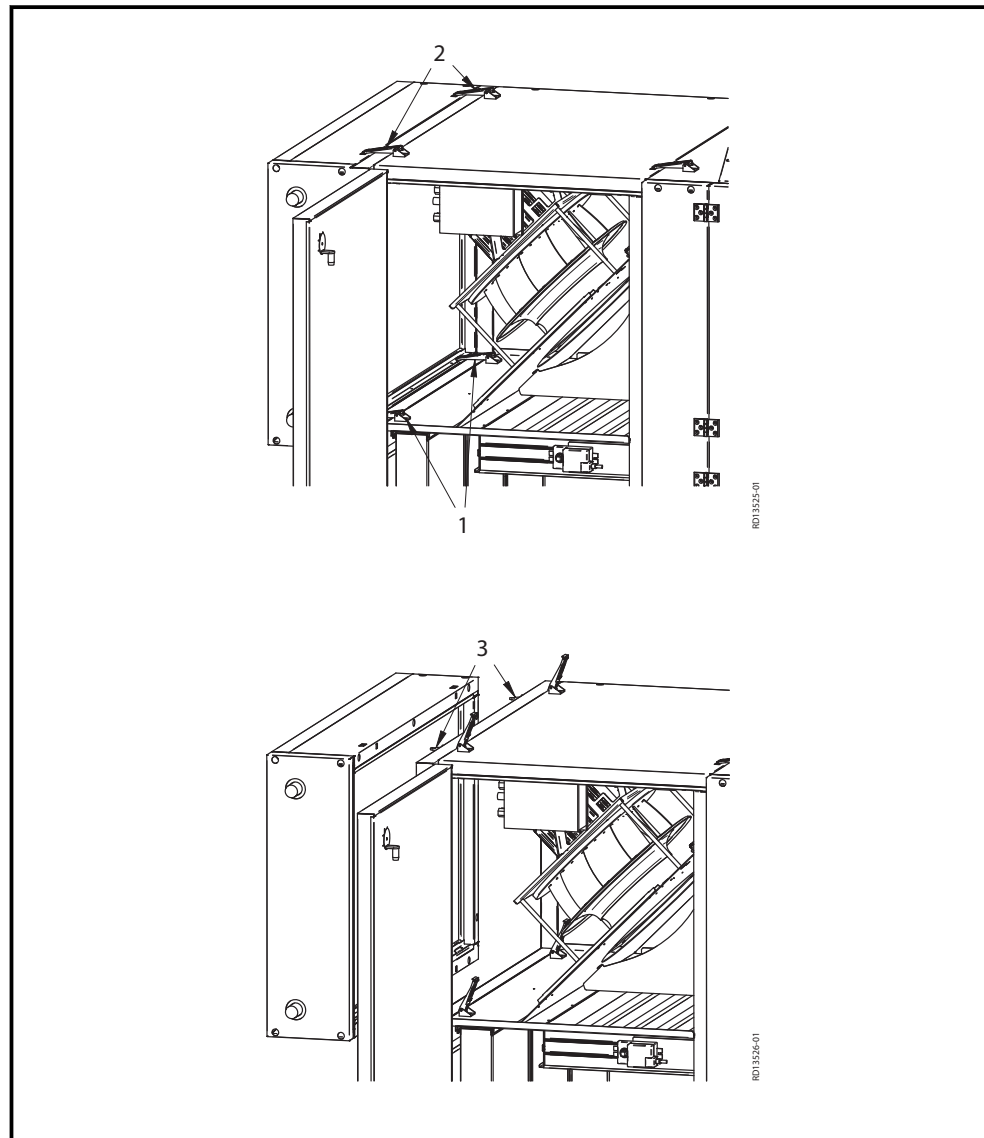

Step	Action
1	Support the heating coil before disassembling it. NB: The heating coil weighs 58 kg. - make sure there are at least two persons to lift the coil off.
2	Open the door of the fan section nearest the heating coil and release the two snap locks (1) inside the VEX.
3	Then release the two snap locks (2) on the top
4	The heating coil can now be lifted from the four guide pins (3).



3. Mechanical assembly

3.1 Installing the unit

3.1.1 Assembly instructions

The assembly of VEX370 is divided into 4 steps as shown below, see the following sections for a detailed description of each step.

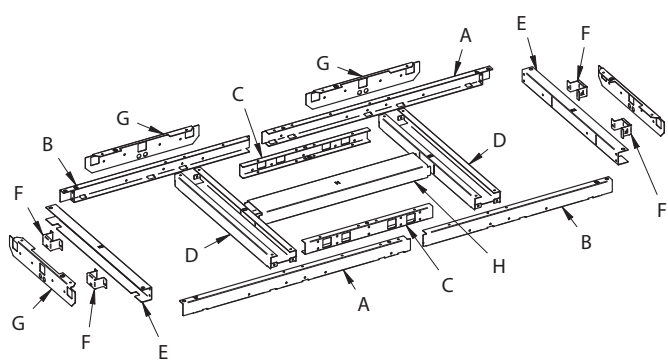
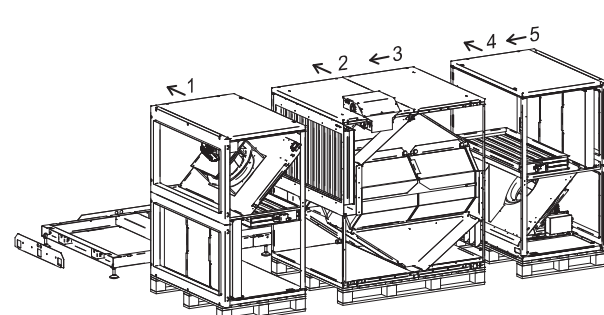
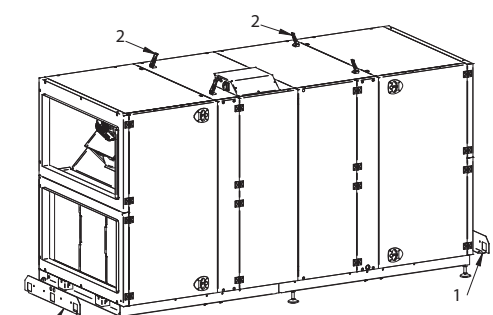
Step 1, assemble the base	
	
Step 2, push the sections onto the base	Step 3 - 4, tighten the VEX section joints
	

Base







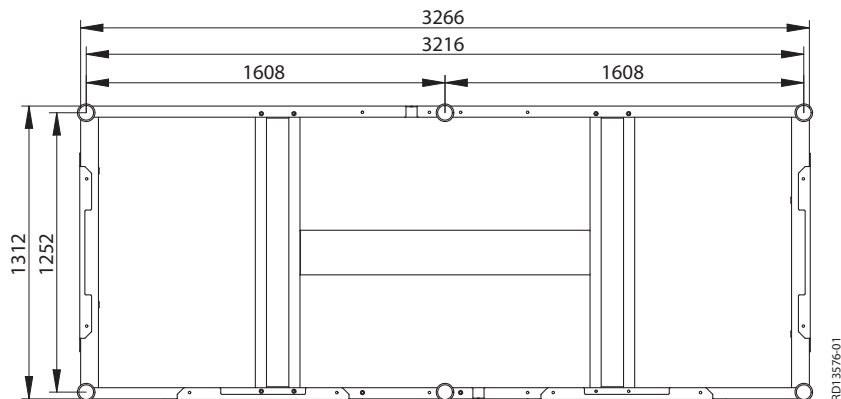



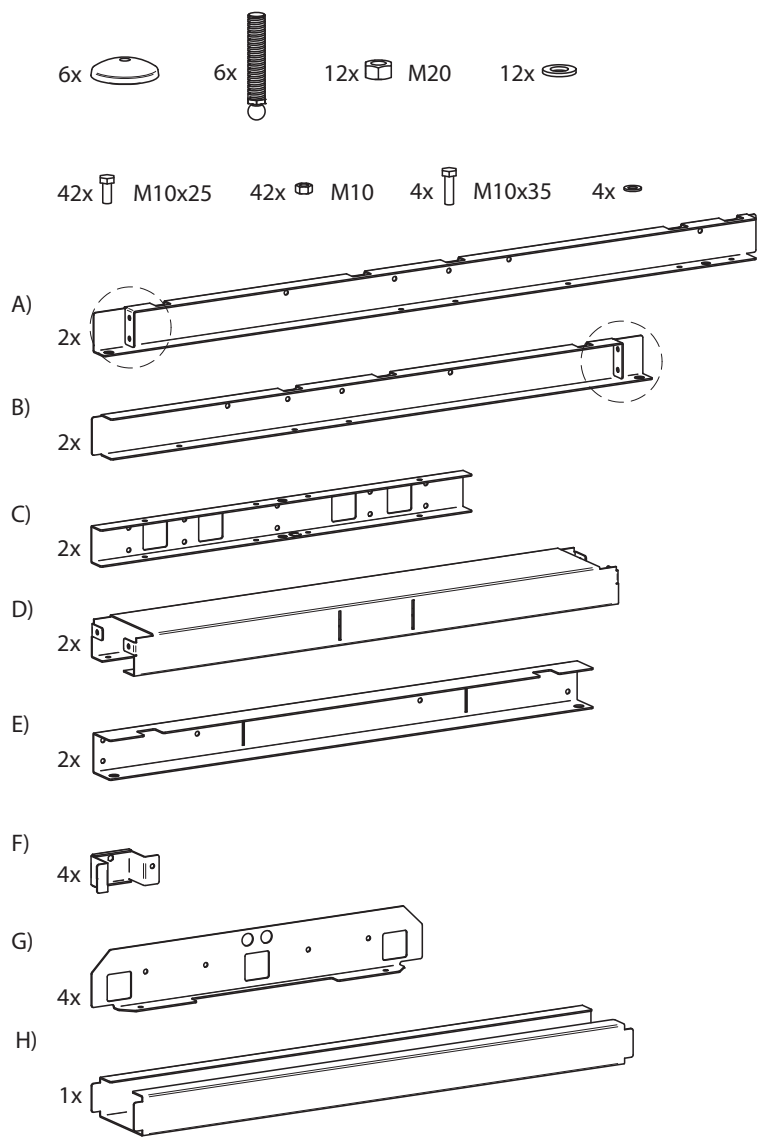

The unit must be assembled on the base – this is essential to ensure its airtightness.

Dimensional drawing

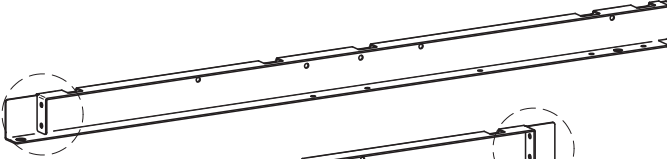
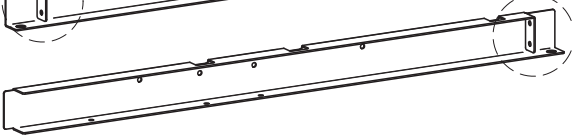
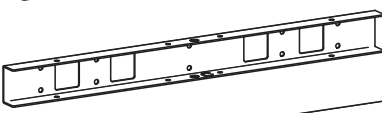
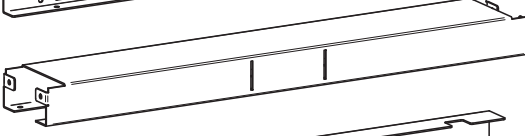
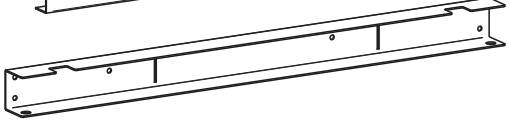

3.1.2 Step 1-4

Step 1, Base: Assemble the base as shown in the drawing below.

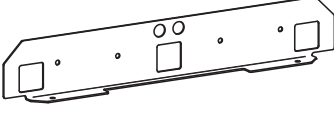
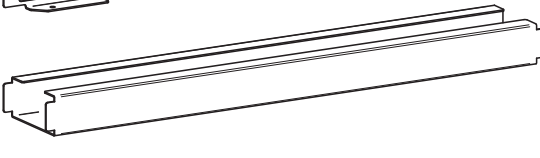
Base assembly	Drawing
<p>The base consists of the following parts:</p>	 <p>6x  6x  12x  M20 12x </p> <p>42x  M10x25 42x  M10 4x  M10x35 4x </p> <p>A) 2x </p> <p>B) 2x </p> <p>C) 2x </p> <p>D) 2x </p> <p>E) 2x </p> <p>F) 4x </p> <p>G) 4x </p> <p>H) 1x </p> <p style="text-align: right;">RD13514-01</p>

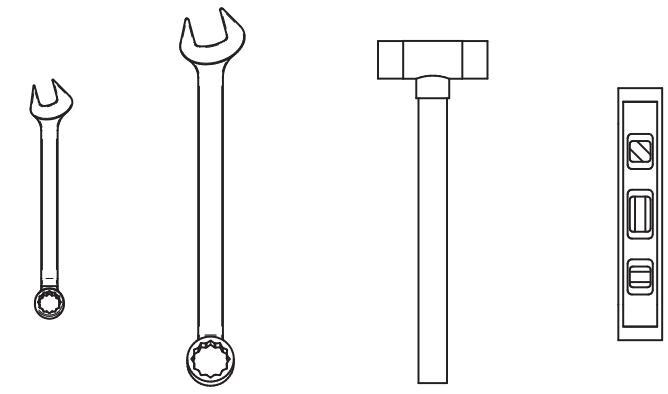
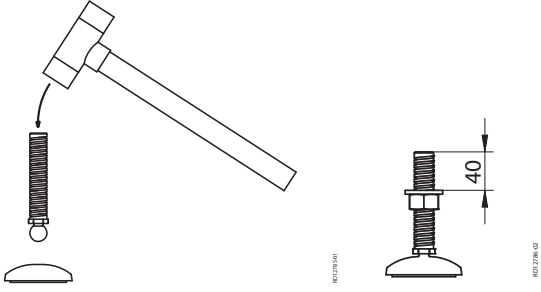
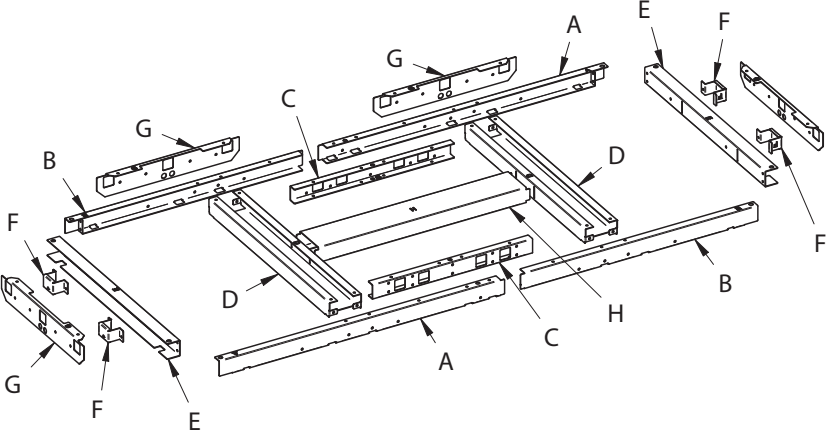
Base assembly	Drawing
<p>The following tools are required:</p>	 <p>2x17mm 2x30mm</p> <p style="text-align: right;">RD12758-01</p>
<p>Assemble the base levelling bolts, by tapping the threaded bar securely into the foot. Screw a nut onto the threaded bar and put a washer on.</p>	 <p style="text-align: right;">RD12758-02</p>
<p>Lay the base parts on the floor with the top facing downwards, as shown in the illustration.</p>	 <p style="text-align: right;">RD13511-01</p>

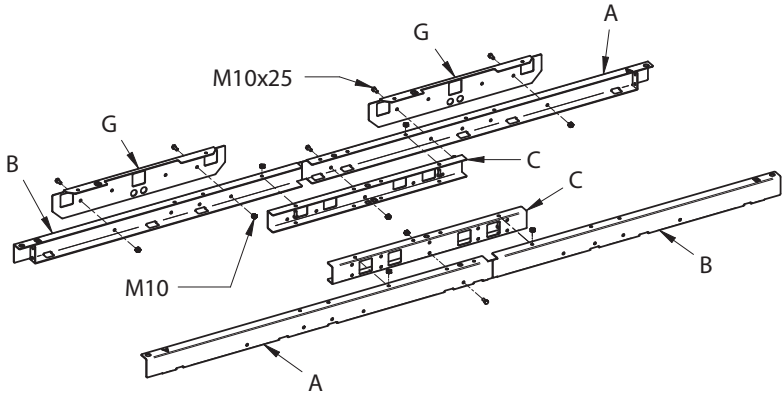
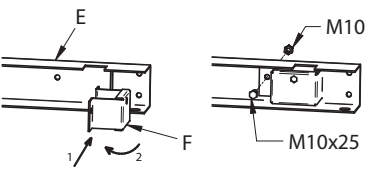
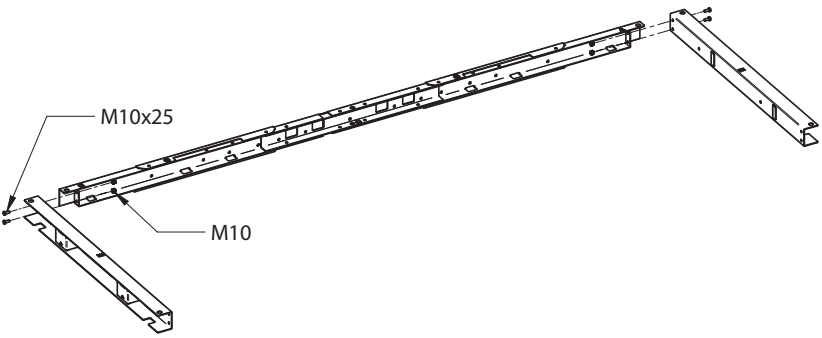
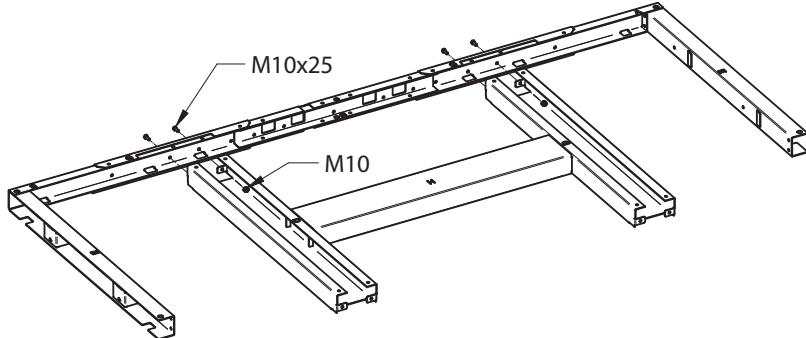
Base assembly	Drawing
<p>Assemble the long pieces:</p> <ul style="list-style-type: none"> • Front long piece: Join A, B and C with nuts and bolts. • Rear long piece: Join A, B, C and G with bolts and nuts. 	 <p>RD13515-01</p>
<p>Fit the two small tension fittings (F) on each side of the short members (G) and secure firmly using nuts and bolts.</p>	 <p>RD13516-01</p>
<p>Firmly screw the two short members (G) to one of the long pieces using nuts and bolts.</p>	 <p>RD13516-01</p>
<p>Fix the spacers with M10 nuts and bolts.</p>	 <p>RD13517-01</p>

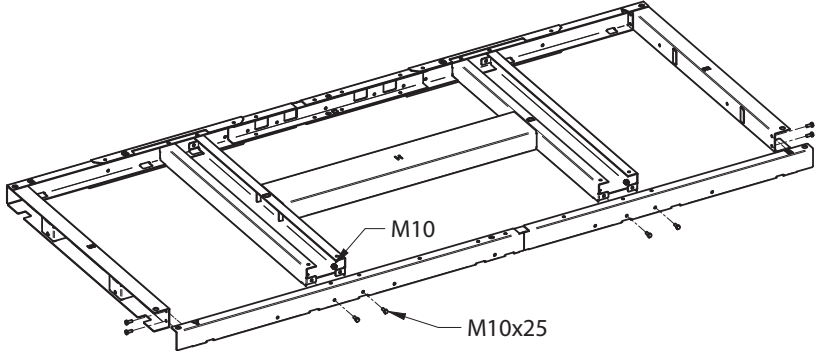
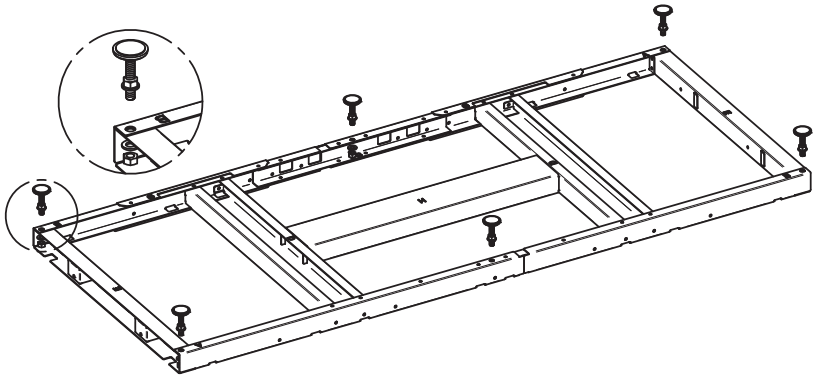
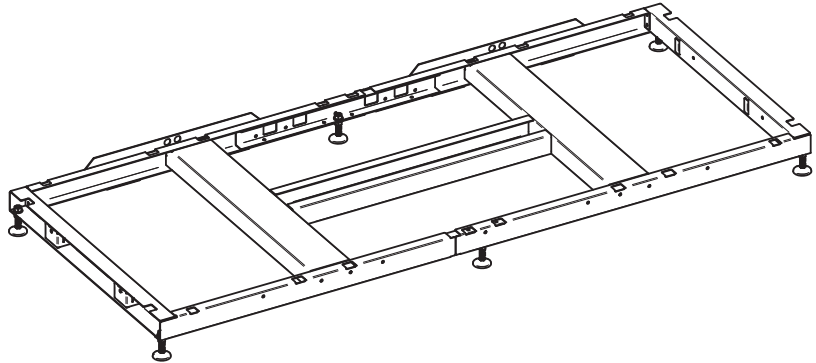
Base assembly	Drawing
<p>Screw the last long piece on using nuts and bolts.</p>	 <p>M10</p> <p>M10x25</p> <p style="text-align: right;">RD13518-01</p>
<p>Screw the levelling bolts on the base with M20 nuts and washers</p>	 <p style="text-align: right;">RD13519-01</p>
<p>Turn the base with legs down and place it so that the tension fittings face away from the operating side</p>	 <p style="text-align: right;">RD13520-01</p>



It is important that the base is levelled before the VEX unit is placed on the base. Adjust the levelling bolts, so that the base is horizontal.

Step 2, VEX sections

Manoeuvre the sections onto the base by pushing them directly from the pallet on to the base.

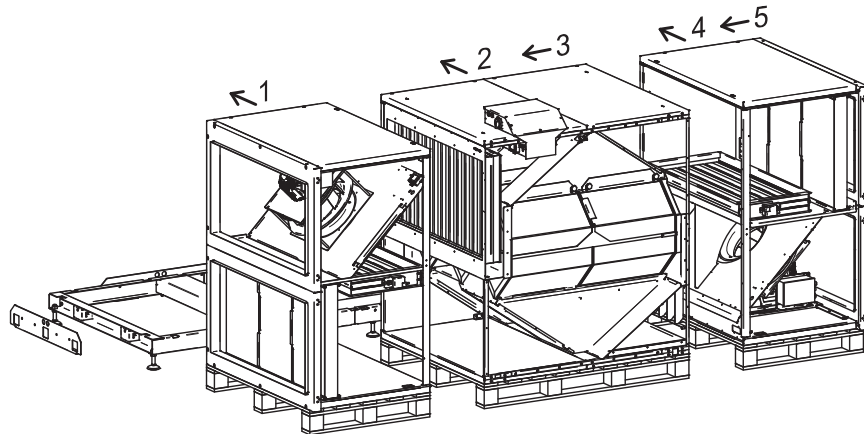

RD1351/201

1. Push a fan section onto the base first
2. Next, push the exchanger section onto the base
3. Push the sections together with the guide pins engaging
4. Push the last fan section onto the base
5. Push the sections together with the guide pins engaging

Step 3, Assembly panels and fittings

When all three sections are on the base:

1. Tighten the two assembly panels against the VEX unit using the four bolts (M10 x 35)
2. Close the four closures on the top of the VEX unit (2).

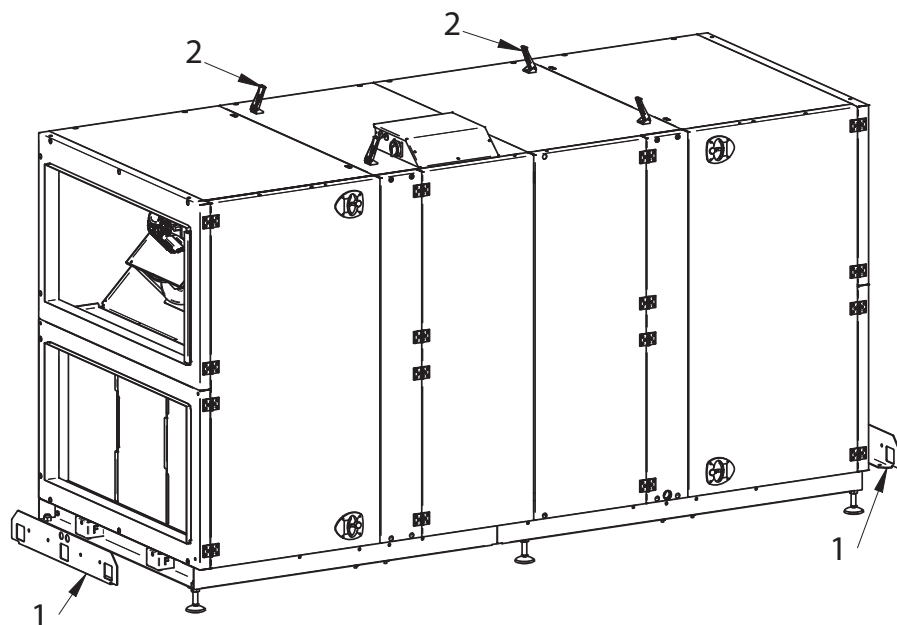

RD13513-01

Step 4, Smooth joints at the condensation tray

To ensure joints are sealed at the condensation tray, the transition between the bottom motor and the condensation tray must be sealed:

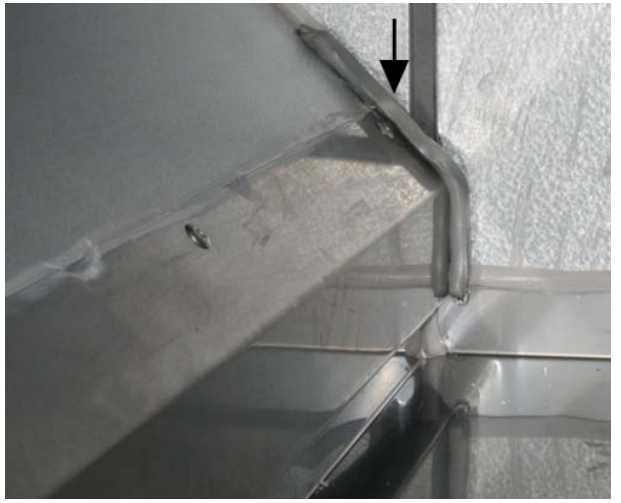
Action	
Smooth the two joints (front and rear on the transition) with a finger. (The arrow shows the rear joint)	

3.2 Condensation drain

3.2.1 Establishment of condensation outlet

Positioning

The following two drawings show examples of how the drain from the condensation outlet can be established and the correct dimensions for the water trap:

Solution with siphon water trap (accessory)

The siphon water trap is easy to install and service.

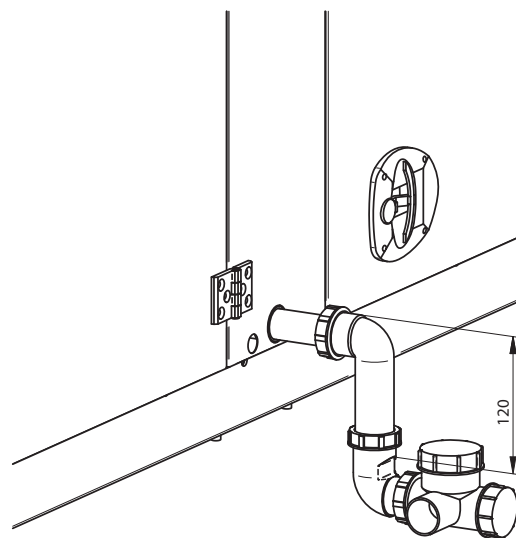

RD13505-01

Solution with HT pipe

Use HT pipe (HT, DN32, DIN4102), if the above solution is not employed (not supplied by EXHAUSTO).

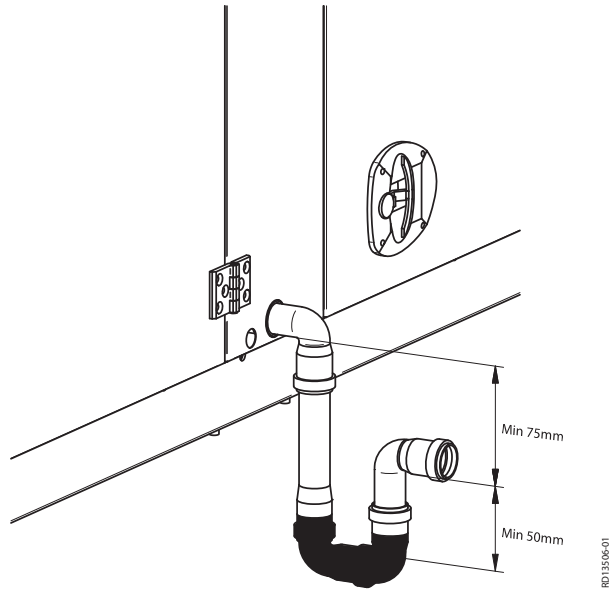

3.3 Integrated water heating coil

3.3.1 Principles for connecting the water heating coil

Mixing loop

The diagrams below are simplified. The dimensioning of valves, pipes, etc. and heating coil connection must always be carried out by authorised fitters in accordance with applicable regulations and legislation.

Type	Principle	Simplified diagram
Mixing loop 1	Variable flow in the primary circuit (supply) and constant flow in secondary circuit (VEX unit)	
Mixing loop 2	Variable flow in the primary circuit (supply) and constant flow in secondary circuit (VEX unit) a) When there is no heating requirement, valve adjustment must be based on the required primary circuit water flow	

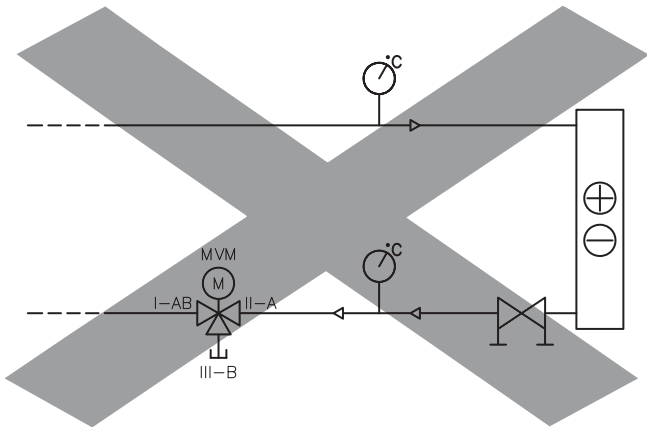
Type	Principle	Simplified diagram
	<p>Do not connect the heating coil like this!</p> <p>Connection without circulation pump risks frost damage!</p>	

Explanation of simplified diagram

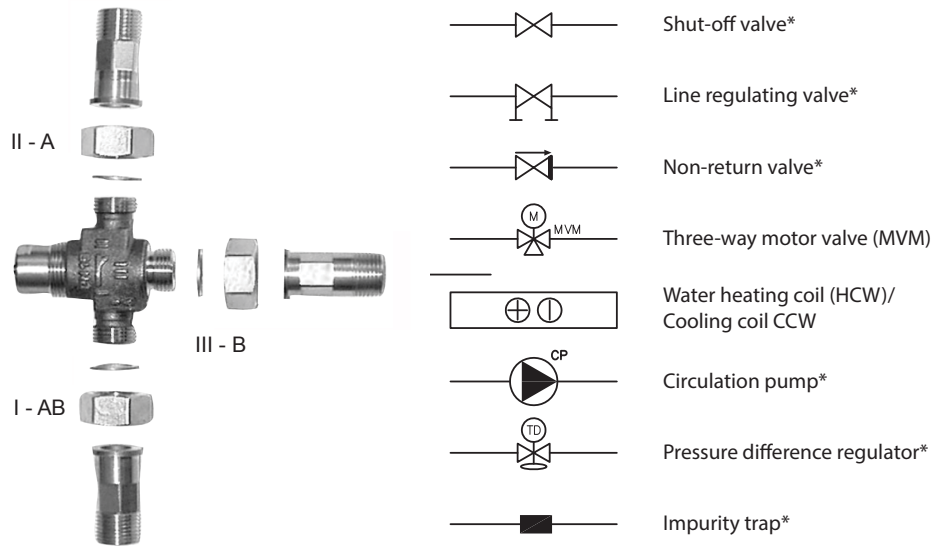

NB The heating coil pipes must not be in the way when opening the nearest door on the VEX for extraction of the fan section. Use a 90° bend on the heating coil connection spigots.

*) not EXHAUSTO delivery (refer to the technical specifications in section 7).

Bleeding Following connection of water supply to the unit:

- Bleed the system thoroughly using the upper bleed screw on the water heating coil

Insufficient bleeding  **Insufficient bleeding can result in still water forming in the system, which may result in frost-induced leaks during the winter.**

Fitting motor valve

The valve must not be fitted with the motor facing down

Insulate the water pipes

The pipes to and from the heating coil must be insulated according to applicable regulations

3.3.2 MVM valve**Screening**

Screen the valve motor from direct sunlight. Due to heat emissions, the valve motor must not be encapsulated (max. ambient temperature: 50°C).

Insulating the valve

To ensure normal operation at ambient temperatures below 0°C, it is very important that the valve section is insulated according to current standards/procedures.

MVM-OD, valve for outdoor fitting

If MVM-OD (MVM intended for outdoor fitting) is used, the screening and insulation are part of the delivery. MVM-OD is only possible for valve sizes below 6.3 K_{VS} .

Regulating properties

Optimal regulation is achieved when the differential pressure is between 5–20 kPa. See section "Technical specifications" to calculate K_{VS} .

Heat supply

The heat supply **must** be constant.

Exercise cycle of circulation pump

The circulation pump is exercised with the EXact2 control, as described here:

1. With no heat requirement, the MVM valve runs at 0%.
2. The circulation pump will then run for a further 5 min and stop.
3. EXact control will start a 24 hour timer.
4. When the 25 hours are over, the circulation pump will exercise for 5 min.
5. The exercise cycle will repeat once a day until the next time a heat requirement arises.



4. Electrical installation

4.1 Electrical installation

See the attached instructions "Electrical Installation Guide VEX350HX-VEX360HX-370HX for third-party control system".

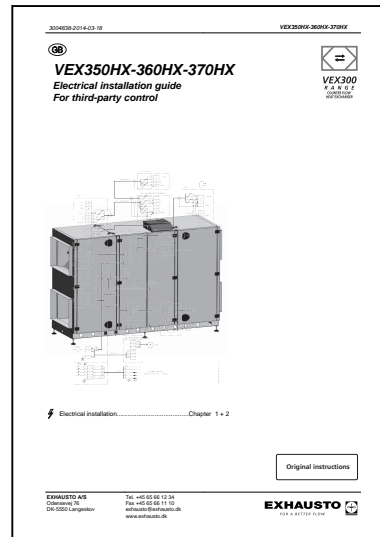



5. Maintenance

5.1 Maintenance Schedule

Recommended intervals The following chart details the recommended maintenance intervals, under normal operating conditions. EXHAUSTO recommends maintenance is adjusted to suit the actual operating requirements.

Component	Procedure	Once a year	Twice a year
Compact/bag filters*	The filter should be changed at least... Recommended that both filters are replaced at the same time.		X
Filter monitor	Check that all the seals in the filter monitor are tight.	X	
Seals and sealing strips	Check that all the seals are tight.	X	
Fans and heating coil (accessories)	Check Dismantling of fan unit, see section "Internal transport with reduced weight" Cleaning, see following sections	X	
Counter flow heat exchanger	Check	X	
Closing damper	Function check	X	
Motor valve and circulation pump (accessories)	Function check	X	

As and when required Following parts are cleaned as and when required

Component	As and when required
Condensation tray	Cleaning and inspection of outlet and water trap
Counterflow heat exchanger	Cleaning. See next sections.

***Filters**



Only use original filters

- The provided filter data and pressure loss graphs (section "Technical data") are based on the use of original filters
- EUROVENT certification is only valid if original filters are used
- Use of non-original filters may cause leakage in the VEX and impair filter function
- EXHAUSTO recommends that you register the filter replacement date to ensure filters are replaced at the correct intervals

5.2 Hygiene

VDI6022 air hygiene standard

To ensure that the VEX300 meets the requirements of the VDI 6022 hygiene standard, its design ensures that:

- bacterial growth and dirt accumulation are minimal
- conditions for cleaning are optimum

Filter F7

The outdoor air side of the unit must be fitted with a F7 filter to meet VDI 6022 requirements.

5.3 Service

5.3.1 Filter change



Disconnect power at the isolation switch before opening the door.

Pull the filters out. Remember to check the flow direction - see the arrows on the filter.

Redundant filters must be stored immediately in sealed plastic bags and disposed of responsibly.

5.3.2 Removing the counter flow heat exchangers



Disconnect power at the isolation switch before opening the door.



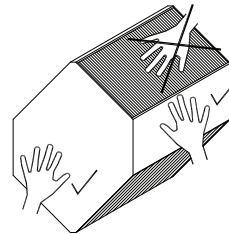

The counter flow heat exchanger fins can be easily damaged - avoid contact with the fins.





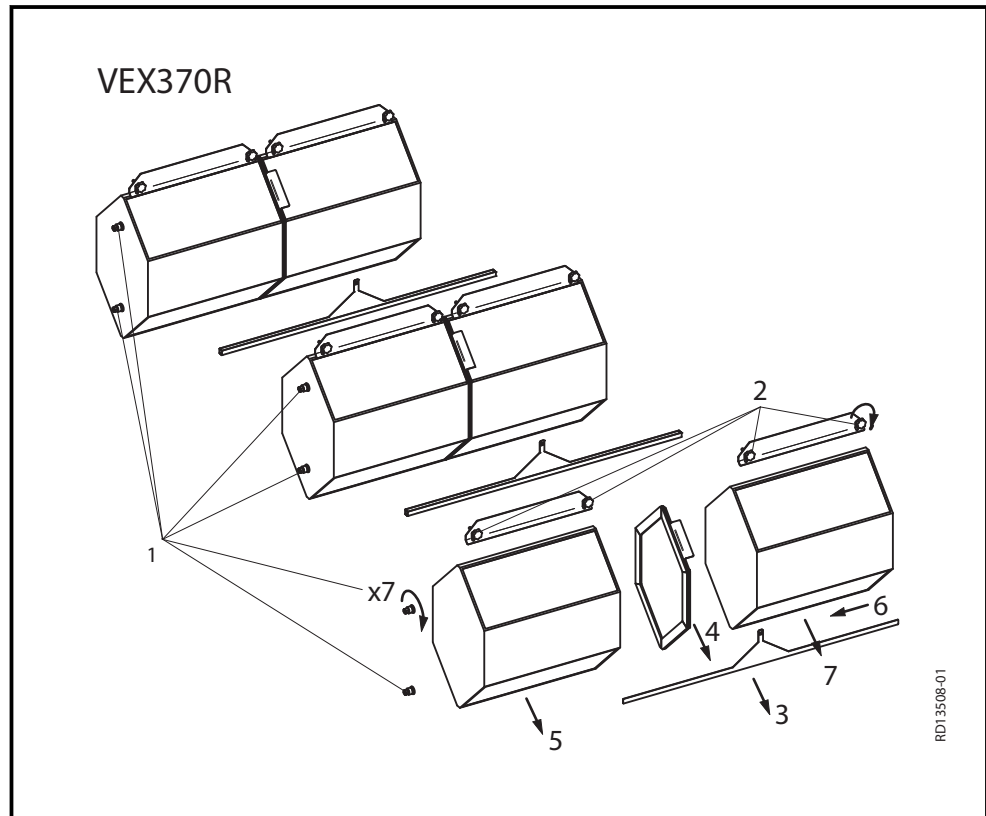

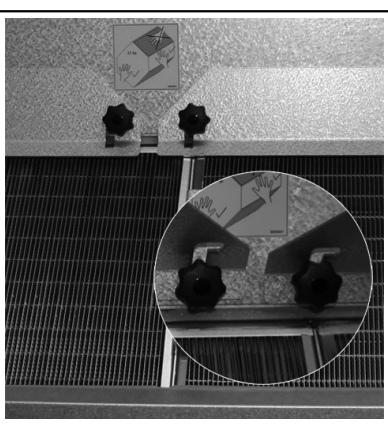

Summary of parts in the heat exchanger section

There is a difference in the sequence for removing counterflow heat exchangers, depending on whether the VEX is a left or right-hand unit. On a left-hand unit the heat exchanger to the left is removed first, while on a right-hand unit the right-hand heat exchanger is removed first.



Step		Action
1		<p>Start by opening the door to the fan section (right-hand section for a left-hand unit) and release the 6 tensioners: turn the tensioner clockwise 7 times.</p>
2		<p>Loosen the finger screws on the bracket. Push the bracket to one side and remove it.</p>

Step		Action
3		Remove the sealing profile in front of the heat exchangers (unhooks).
4		Remove the sealing panel between the heat exchangers (pull the handle).
5		Remove the first heat exchanger. NB: A single heat exchanger weighs 19 kg.
6+7		Push the other heat exchanger to the side and remove it also.

Step		Action
8		<p>Use the first of the two panels on the inside of the door in the heat exchanger section as an underlay for the next row of heat exchangers. Lay the panel at the side from which the heat exchanger is to be removed. Remove the heat exchangers in the same way as described above.</p>
9		<p>Use the final panel as an underlay for the rear row of heat exchangers. These are also removed as described above.</p>

5.3.3 Servicing and cleaning

Cleaning the counter flow heat exchanger:

- Clean the exchanger by flushing with hot water
- Water temperature max. 90°C.

How to clean the fan

See section "Internal transport with reduced weight" for details on how to remove the fan units.

Step	Action
1	Switch off the power supply to the unit at the isolation switch
2	Clean the fan impellers with a vacuum cleaner and by wiping with a damp cloth NB: Clean the impellers carefully to avoid disturbing the balance
3	Once re-fitted, check the unit operates without vibrating

Cleaning cold water coil/heating coil

Step	Action
1	Switch off the power supply to the unit at the isolation switch

Step	Action
2	Vacuum clean the heating coil
3	Cold water coil: clean the condensation tray

Scan the QR code
and see the video
about removal

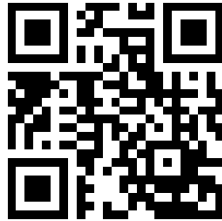

5.4 Airflow measurement

5.4.1 Determining airflow and pressure

Use the formulae in the table to calculate airflow and pressure drop over the filters.

Airflow:	Airflow q_V (l/s, m ³ /h) can be read from the differential pressure Δp_M [Pa]
Extract air	$\Delta p_{M1.2} = P_{1.2X} - P_{1.2Y}$ [Pa]
Supply air	$\Delta p_{M2.2} = P_{2.2X} - P_{2.2Y}$ [Pa]

Pressure drop across:	
Extract air filter	$\Delta p_{1.1} = P_{1.1X} - P_{1.1Y}$ [Pa]
Supply air filter	$\Delta p_{2.1} = P_{2.1X} - P_{2.1Y}$ [Pa]

Location of measurement points

The location of measurement points is shown on the drawing:

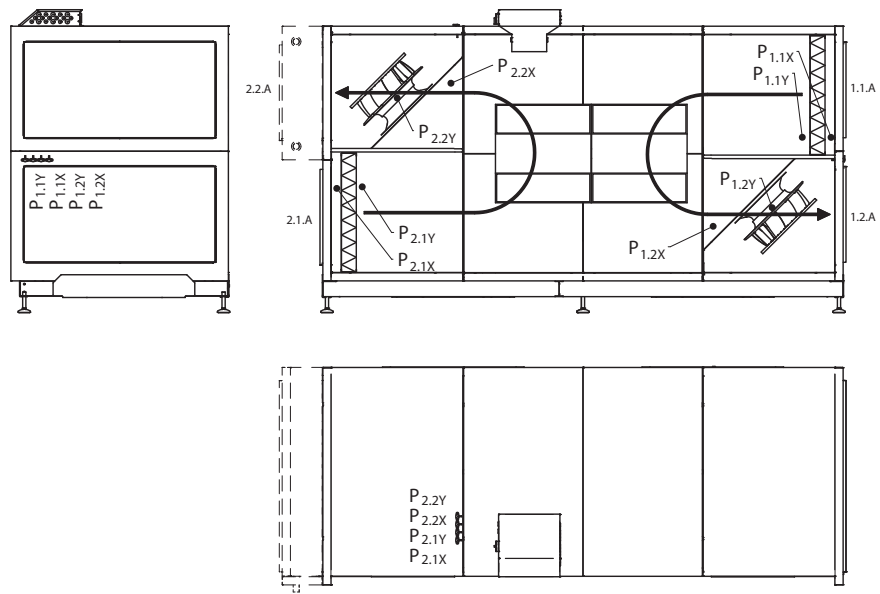

RD13530-01

Supply air:

Airflow diagram for supply air

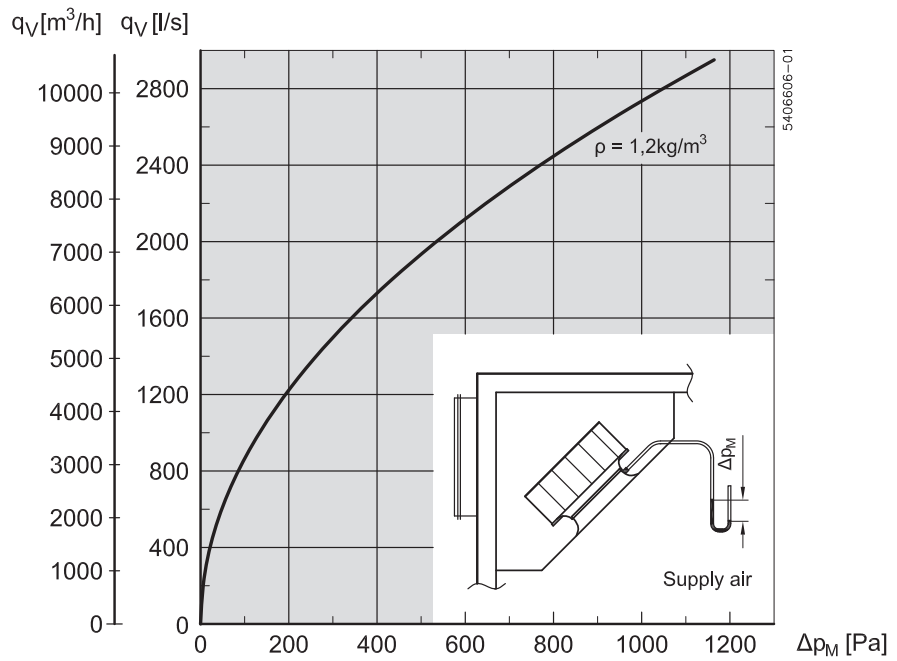

— Airflow (q_V) according to pressure difference (Δp_M)

$$\left. \begin{aligned} q_V &= 241,2 \cdot \sqrt{\frac{2 \cdot \Delta p_M}{\rho}} \text{ [m}^3/\text{h]} \\ q_V &= 67 \cdot \sqrt{\frac{2 \cdot \Delta p_M}{\rho}} \text{ [l/s]} \end{aligned} \right\} \pm 10\% \text{ for } \Delta p_M > 40 \text{ Pa}$$

Extract air:

Airflow diagram for extract air

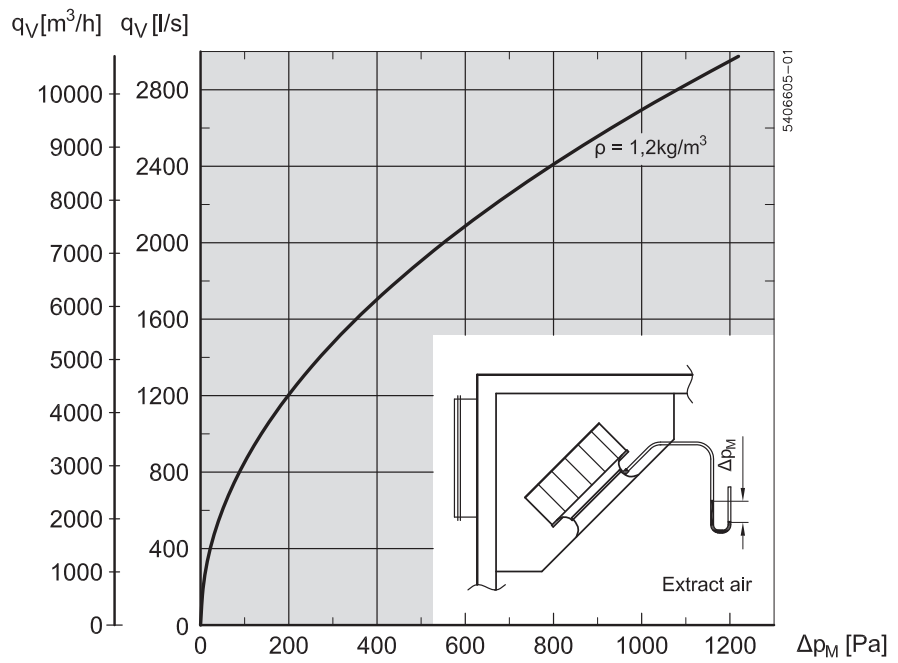

— Airflow (q_V) according to pressure difference (Δp_M)

$$\left. \begin{aligned} q_V &= 237,6 \cdot \sqrt{\frac{2 \cdot \Delta p_M}{\rho}} \text{ [m}^3/\text{h]} \\ q_V &= 66 \cdot \sqrt{\frac{2 \cdot \Delta p_M}{\rho}} \text{ [l/s]} \end{aligned} \right\} \pm 10\% \text{ for } \Delta p_M > 40 \text{ Pa}$$



6. Technical data

6.1 Weight, corrosion class, temperature ranges, etc.

Weight

Weight	1,018 kg
--------	----------

Corrosion class

Corrosion class	Corrosion class C4 in accordance with EN ISO 12944-2
-----------------	--

Temperature ranges

Outdoor air temperature	-40°C to +35°C
Ambient temperature	-30°C to +50°C

At temperatures below -25°C (with outdoor installation), use of a thermostatically controlled heater in automated control box is recommended.

Motor damper

Motor damper type	LS600x120024	LSR600x120024
Designation	LSA/LSF	LSFR
Motor type	NM24-F	AF-24
Rotation time	75–150 s	open: 150 s close: 16 s
Ingress protection	IP42	IP42
Ambient temperature	-20°C to +50°C	-30°C to +50°C
Damper depth (LS rail system)	115 mm	115 mm
Damper depth (METU rail system)	170 mm	170 mm

A maximum of two LSFR dampers or four LSA/LSF dampers may be connected.

Motor data

Voltage	3 x 400 V
Max. rpm	2900 rpm
Torque	13,5 Nm
Motor class in accordance with IEC TS 60034-30-2	IE5 (Ultra Premium efficiency)

6.2 Compact filters

Pressure loss curves for M5 and F7 filters

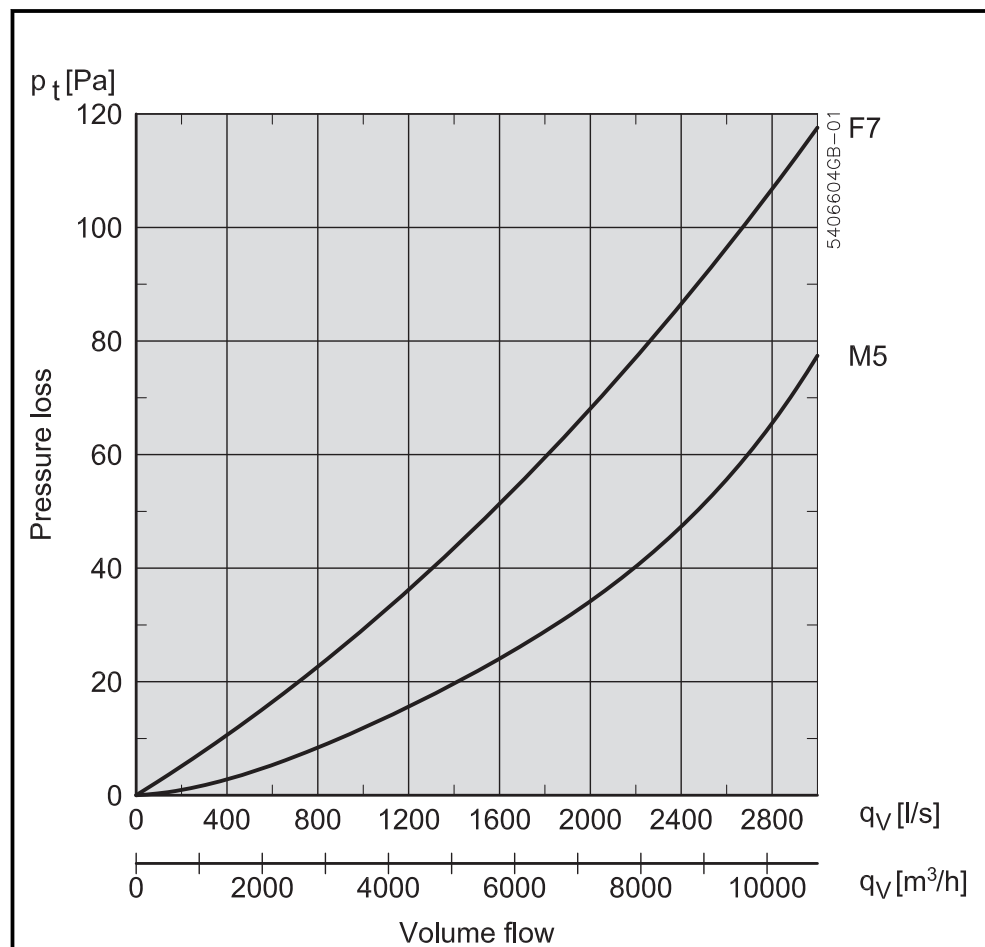

Filter data	M5	F7
Filter panel h x b (qty. 3 per air direction)	414 x 750 mm	414 x 750 mm
Panel filter thickness	96	96
Efficiency	45 %	85 %
Recommended difference between final pressure drop and initial pressure drop	+100 Pa	+100 Pa



EUROVENT certification is only valid if original filters are used. For more details about original filters, see section "Maintenance".

6.3 Bag filters

Pressure loss curves for M5 and F7 filters

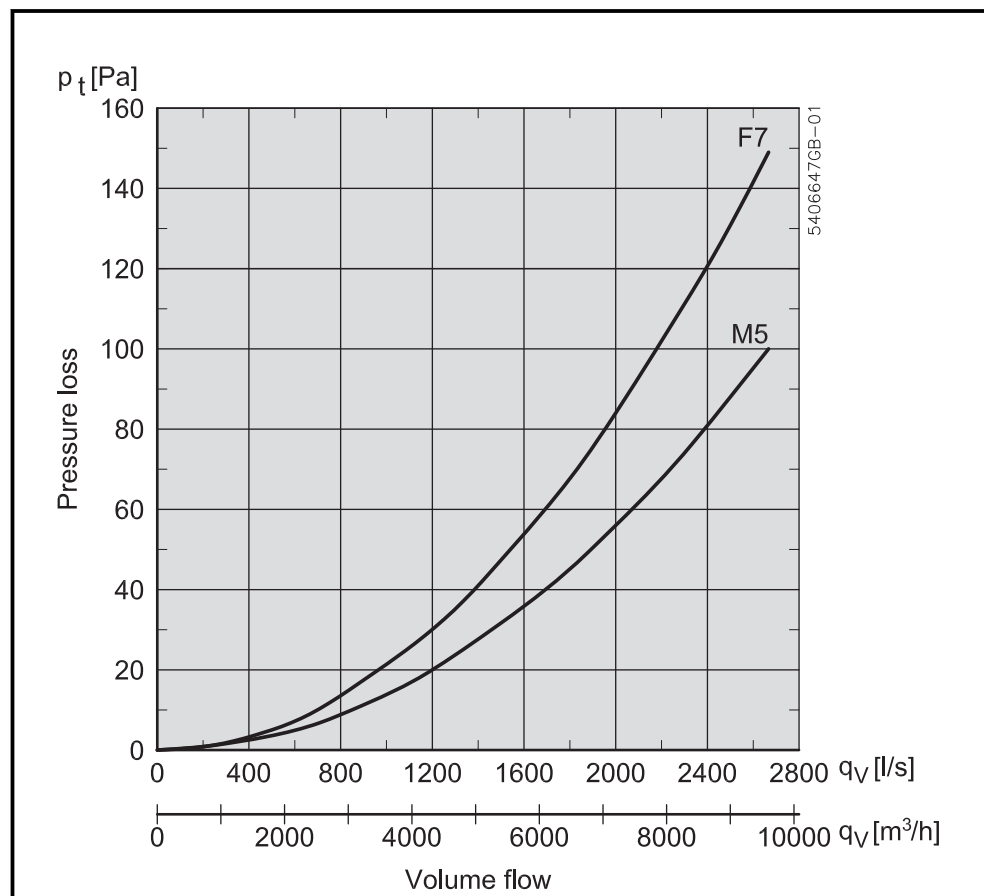

Filter data	M5	F7
Filter area h x b (qty. 2 per air direction)	2 x 592 x 592mm	2 x 592 x 592mm
Total number bags x depth	2 x 6 x 520mm	2 x 10 x 520mm
Volume flow rate	7500 m³/h	7500 m³/h
Initial pressure drop	57 Pa	85 Pa
Recommended difference between final pressure drop and initial pressure drop	+100 Pa	+100 Pa



EUROVENT certification is only valid if original filters are used. For more details about original filters, see section "Maintenance".

6.4 Integrated water heating coil HCWi

Integrated water heating coil

		HCWi
Weight/content	Weight without fluid	35 kg
	Water content	11.8 l
Dimensions	Face area (h x b)	700 x 1,175 mm
Data	Test pressure	3000 kPa

		HCWi
	Max. operating pressure	1000 kPa
	Number of pipe rows	qty. 3
	Number of circuits	qty. 15
	Pipe connection	DN32 (1¼")
	Fin spacing	2.3 mm
	Permissible media temperature	5..0.95°C

Recommendation



A precise calculation of the heating coil is recommended, to be carried out with calculation program EXselect, available on www.exhausto.dk.

6.4.1 MVM motor valve

Valve	K _{Vs} 1.0 - 4.0	K _{Vs} 6.3
Test pressure	1600 kPa	1600 kPa
Max. differential pressure	100 kPa	200 kPa
Permissible media temperature	5°C - 110°C	5°C - 110°C
The valve will remain permanently open if the differential pressure	is greater than 100 kPa	is greater than 200 kPa

Motor	K _{Vs} 1.0 - 4.0	K _{Vs} 6.3
Permissible ambient temperature	-30°C - +50°C	-30°C - +50°C
Ingress protection, in accordance with IEC	IP40	IP40
Time taken to open/close	34 s	30 s
Power supply (50/60 Hz, AC/DC)	24VAC ±20% 24 VDC ±20%	24VAC ±20% 24 VDC ±20%
Regulation	0–10 VDC	0–10 VDC

6.5 Capacity diagram

6.5.1 Capacity diagram, ventilation with heat recovery

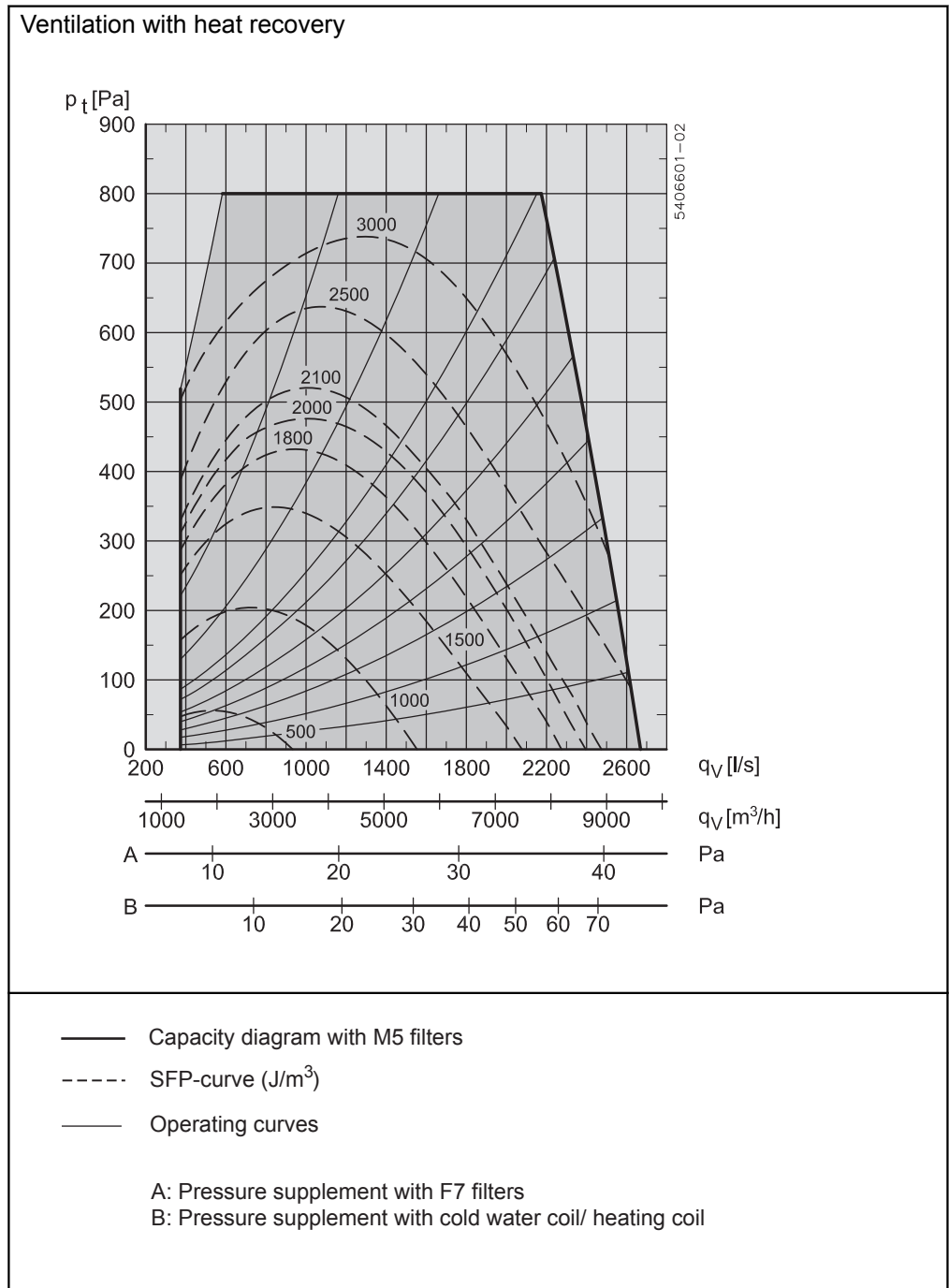

6.5.2 Capacity diagram, ventilation with bypass operation

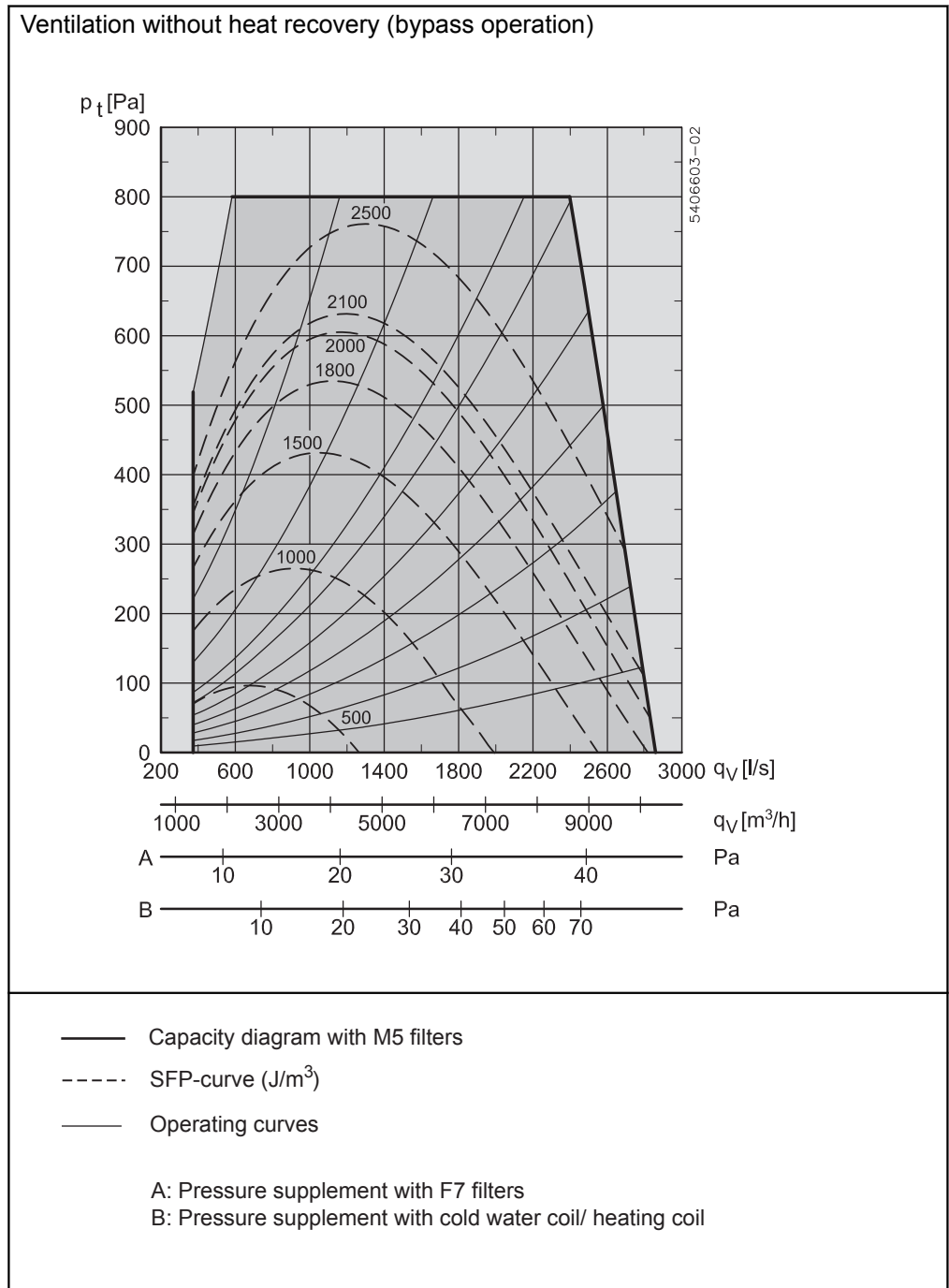

6.6 Ordering spare parts

Find production number

When ordering spares, please state the relevant production part number. This will ensure that the correct parts are delivered. The production number is given on the front of the VEX guidelines and on the VEX rating plate.

Contact:

Contact your local EXHAUSTO office service department to order a spare part. Contact information is given on the back cover of these instructions. See also the "Layout" section for an overview of the position and designation of parts in the VEX.



Scan code and go to addresses at
www.exhausto.com