

Notice d'installation **FR**

Installation instructions **EN**

Installationsanleitung **DE**

Montagehandleiding **NL**

Instrucción de utilización **ES**

Manuale di installazione **IT**



# EasyVEC®



[www.aldes.com](http://www.aldes.com)

# 1. GÉNÉRALITÉS • GENERAL INFORMATION • ALLGEMEINES • ALGEMEEN • GENERALIDADES • GENERALITÀ

## 1.1. Documents de référence associés • Related reference documents • Zugehörige Referenzdokumente • Bijbehorende referentiedocumenten • Documentos de referencia asociados • Documenti di riferimento associati

Documents / Documents / Dokumente / Documenten / Documentos / Documenti	Aldes.com
Guide de démarrage rapide / Quick Start Guide / Kurzanleitung / Snelstartgids / Guía de arranque rápido / Guida per l'avvio rapido	✓
Documentation commerciale / Sales brochure / Verkaufsdokumentation / Verkoopdocumentatie / Documentación comercial / Documentazione commerciale	✓
Documentation technique / Technical documentation / Technische Dokumentation / Technische documentatie / Documentación técnica / Documentazione tecnica	✓
PV C4	✓
Tutoriels d'installation et de maintenance / Installation & maintenance tutorials / Installations un Wartungstutorials / Montage- en onderhouds zelfstudiegids / Tutoriales de instalación y de mantenimiento / Tutorial di installazione e di manutenzione	<p>FR</p>  <p>EN</p> 

1.2. Schéma de principe • Layout diagram • Schaltplan • Blokschema • Esquema de principio • Schema generale

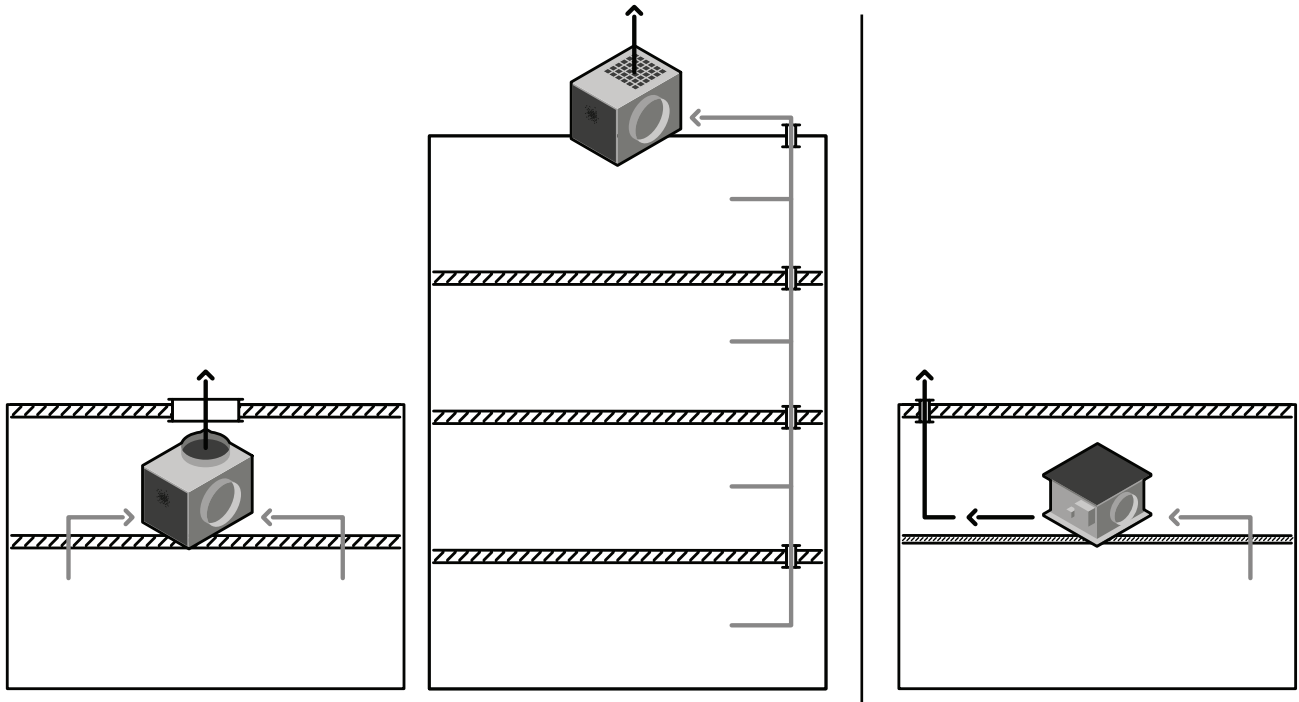

1.3. Vue éclatée • Exploded view • Explosionszeichnung • Explosietekening • Vista despiezada • Vista esplosa

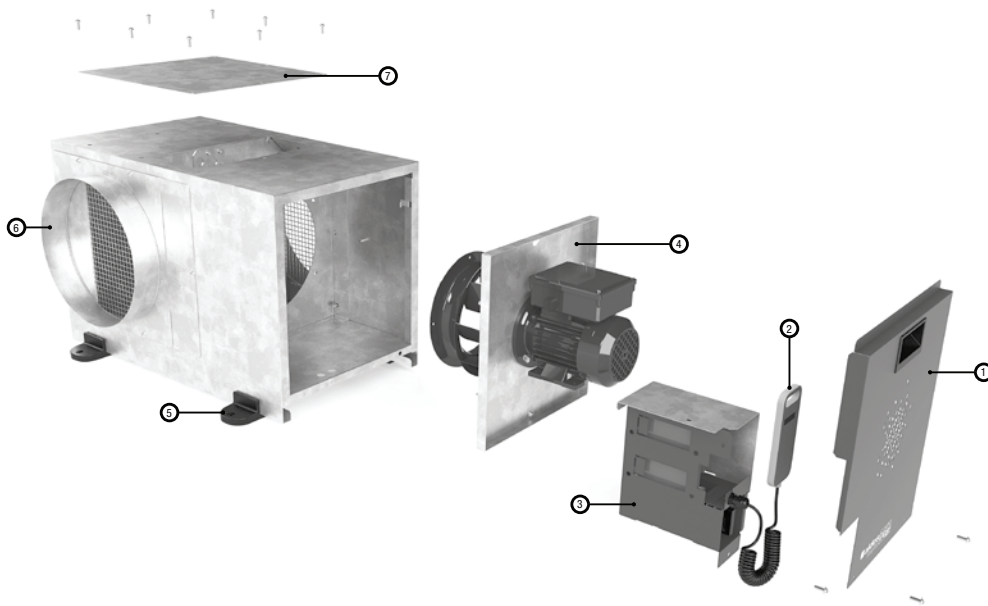

	FR	GB	DE	NL	ES	IT
1	Panneau d'accès	Access panel	Abdeckplatte	Toegangspaneel	Panel de acceso	Pannelo di accesso
2	Télécommande	Remote control	Fernbedienung	Afstandsbediening	Telecomando	Telecomando
3	Boîtier électronique	Electrical box	Schaltkasten	Elektronische module	Caja electrónica	Unità elettronica
4	Moto-ventilateur	Fan	Motorventilator	Elektrische ventilator	Motoventilador	Motoventilatore
5	Pied isolant (accessoire)	Insulating base (accessory)	Isolierfuß (Zubehör)	Isolatievoet (accessoire)	Pie aislante (accessorio)	Piede isolante (accessorio)
6	Piquage	Branch	Messanschluss	Leidingsaansluiting	Derivación	Presa
7	Bouchon ou grille	Plug or grille	Verschluss oder Gitter	Afsluitdop of rooster	Tapón o rejilla	Tappo o griglia

# 1.4. Encombrement • Dimensions • Abmessungen • Afmetingen • Dimensiones generales • Ingombri

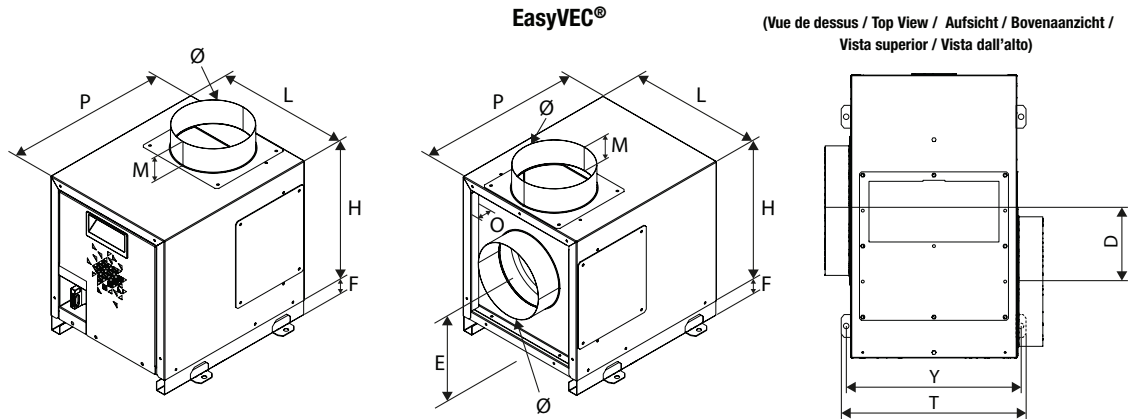

EasyVEC®	P (mm)	L (mm)	H (mm)	Ø (mm)	D (mm)	E (mm)	F (mm)	M (mm)	O (mm)	Y (mm)	T (mm)	kg
300	372	302	321	160	-	205	35	57	25	340	356	12
300*	374	354	347	160	-	205	35	57	0,8	392	408	15
700	562	352	371	250	125	230	35	58	25	390	406	16
700*	564	404	397	250	125	230	35	58	0,8	442	458	20
1000	688	402	421	315	157,5	255	35	63	25	440	456	19
1000*	691	454	447	315	157,5	255	35	63	0,8	492	508	25
1500	688	402	421	315	157,5	255	35	63	25	440	456	21
1500*	691	454	447	315	157,5	255	35	63	0,8	492	508	27
2000	738	452	471	355	177,5	280	35	63	25	490	506	30
2000*	741	504	497	355	177,5	280	35	63	0,8	542	558	39
2500	795	502	521	400	200	305	35	73	25	540	556	40
2500*	797	554	547	400	200	305	35	73	0,8	592	608	52
3000	795	502	521	400	200	305	35	73	25	540	556	42
3000*	797	554	547	400	200	305	35	73	0,8	592	608	54

## EasyVEC® Compact

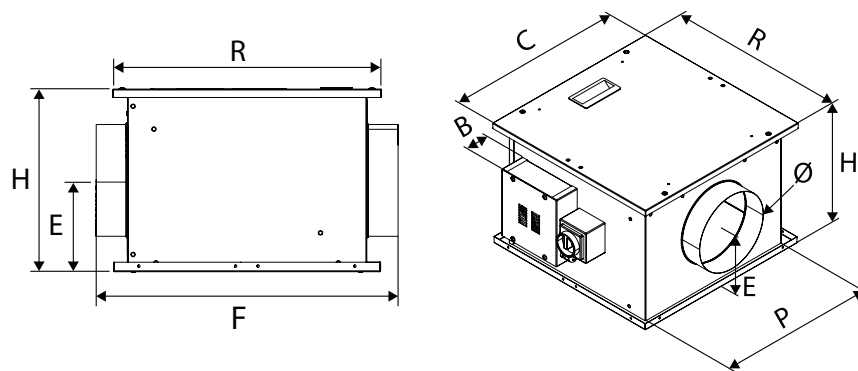

EasyVEC® Compact	B	C	P	R	F	H	E	Ø (mm)	kg
EasyVEC® 300 Compact	93	432	377	432	488	277	139	160	9
EasyVEC® 300 Compact isolé	67	432	427	432	488	279	140	160	14
EasyVEC® 600 Compact	93	482	427	482	538	327	164	200	12
EasyVEC® 600 Compact isolé	67	482	477	482	538	329	165	200	19
EasyVEC® 1000 Compact	93	532	477	532	588	352	177	250	14
EasyVEC® 1000 Compact isolé	67	532	527	532	588	354	178	250	22
EasyVEC® 2000 Compact	93	582	527	582	648	352	177	315	20
EasyVEC® 2000 Compact isolé	67	582	577	582	648	354	178	315	26

\* isolé / insulated / isoliert / los / aislado / isolato



## 2. DESCRIPTION GÉNÉRALE • GENERAL DESCRIPTION • ALLGEMEINE BESCHREIBUNG • ALGEMENE BESCHRIJVING • DESCRIPCIÓN GENERAL • DESCRIZIONE GENERALE

### 2.1. Déchargement • Unloading • Entladen • Uitladen • Descarga • Scarico

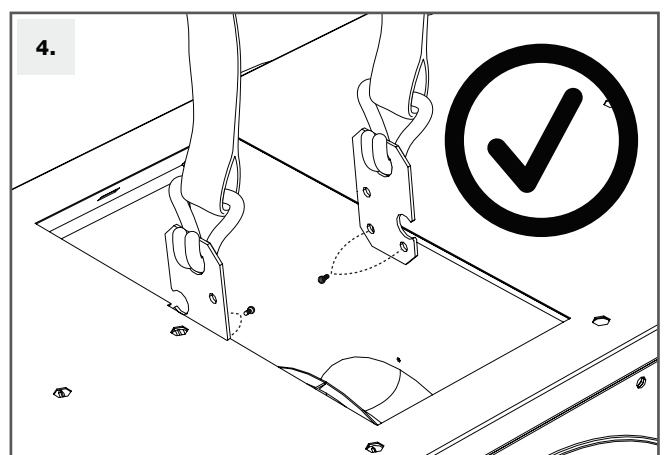
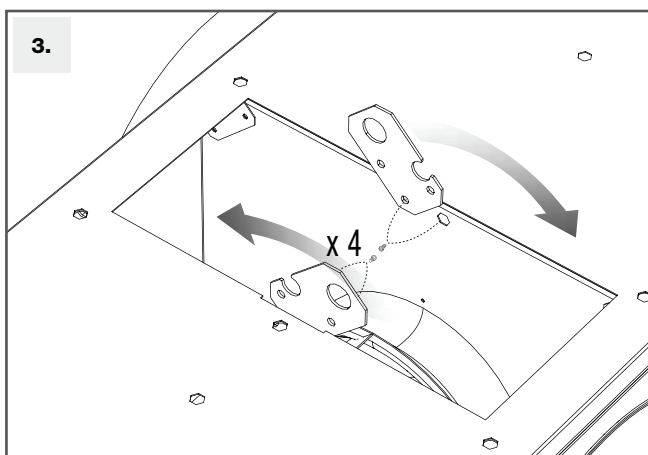
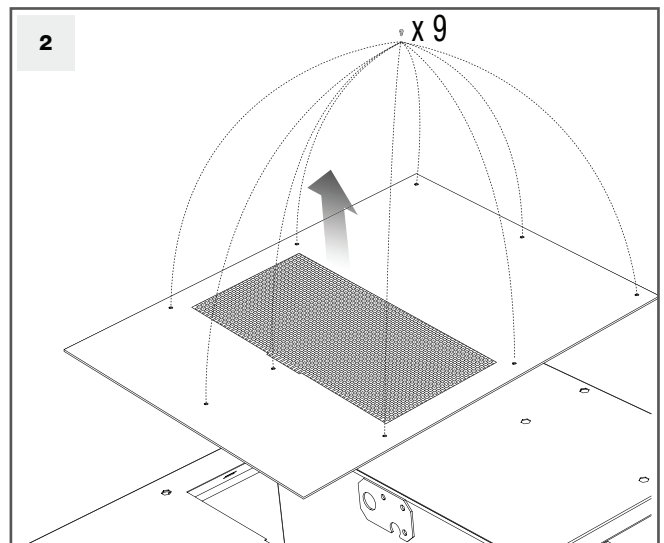
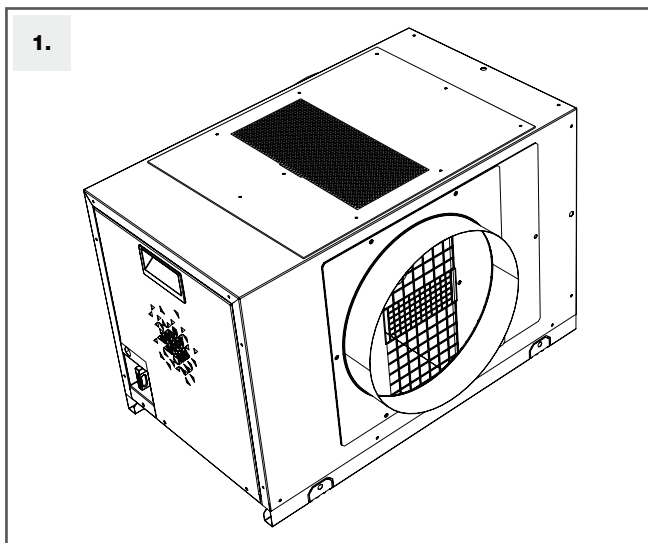
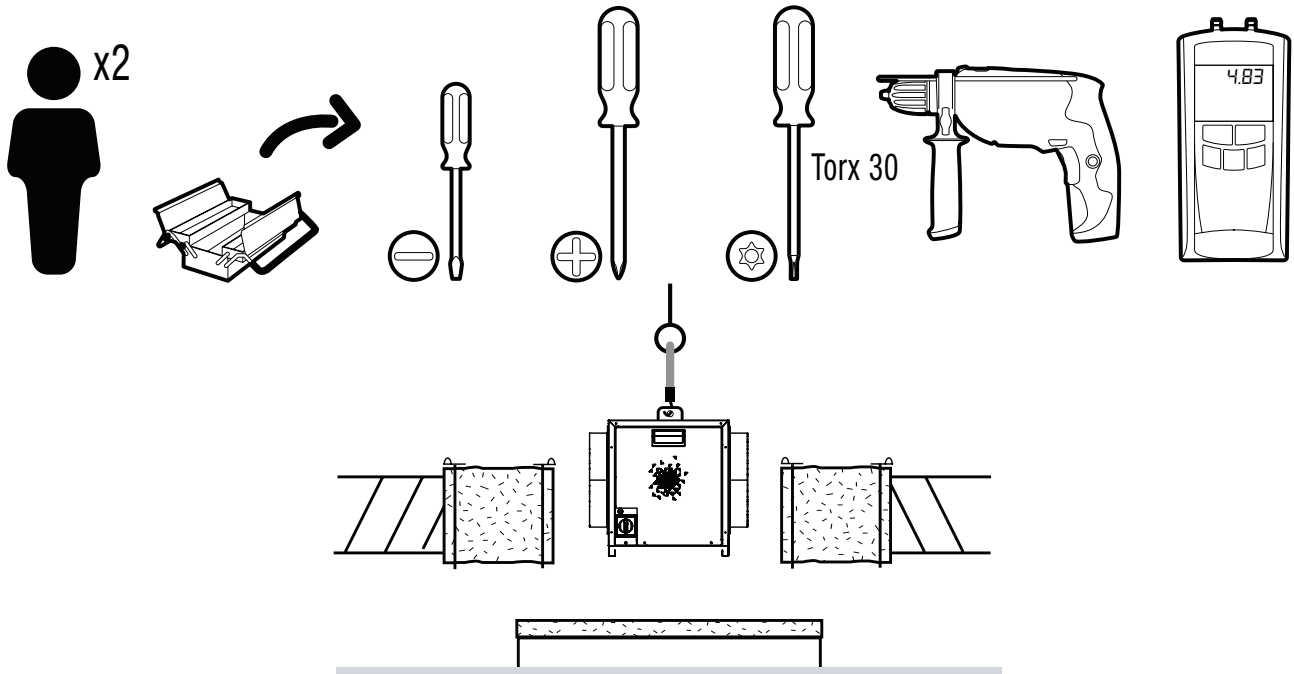

## 2.2. Déballage • Unpacking • Auspacken • Uitpakken • Desembalaje • Disimballaggio

EasyVEC®

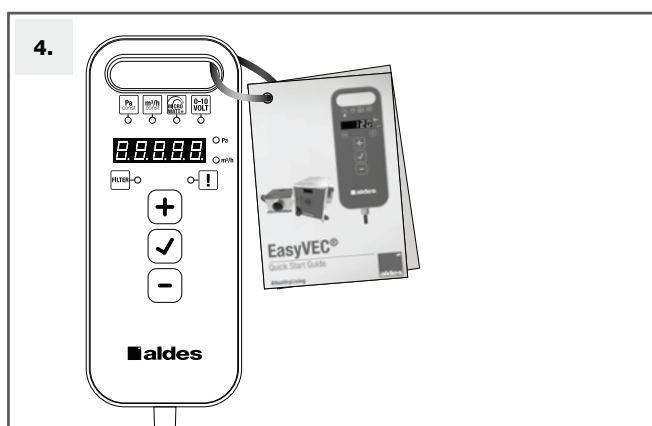
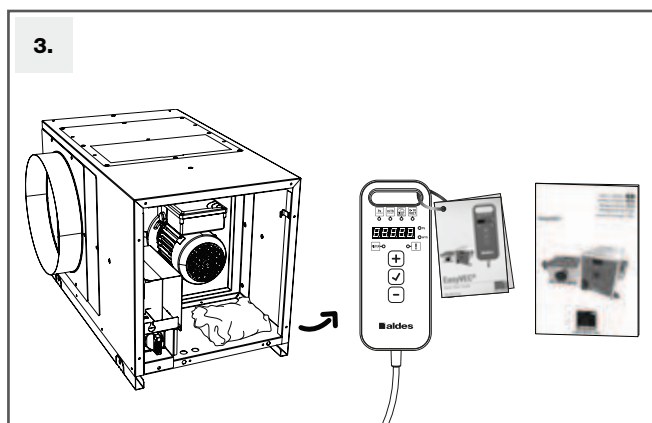
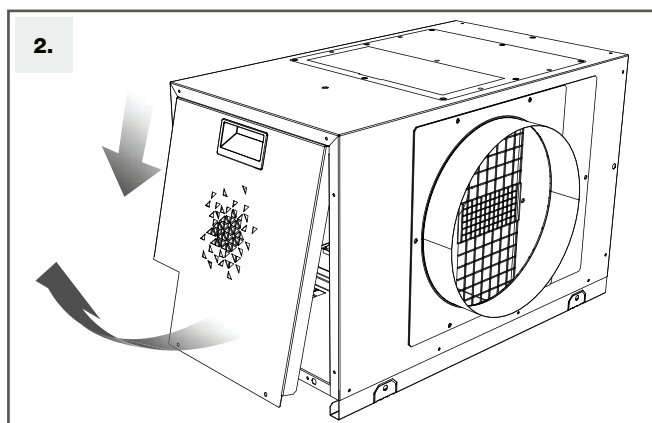
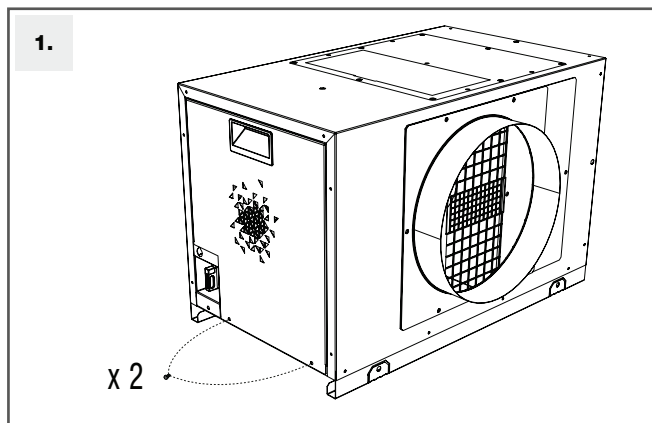

EasyVEC® Compact

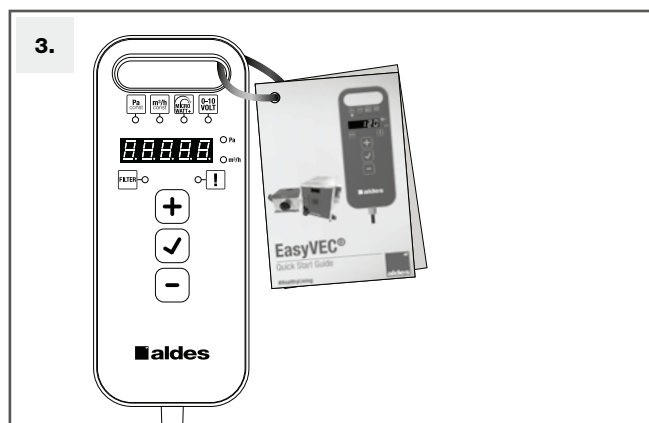
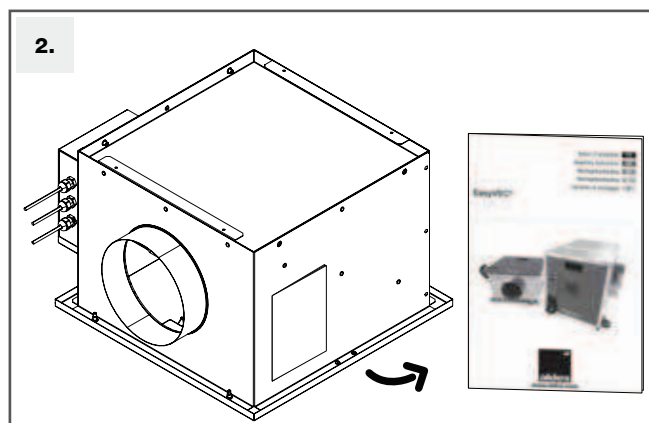
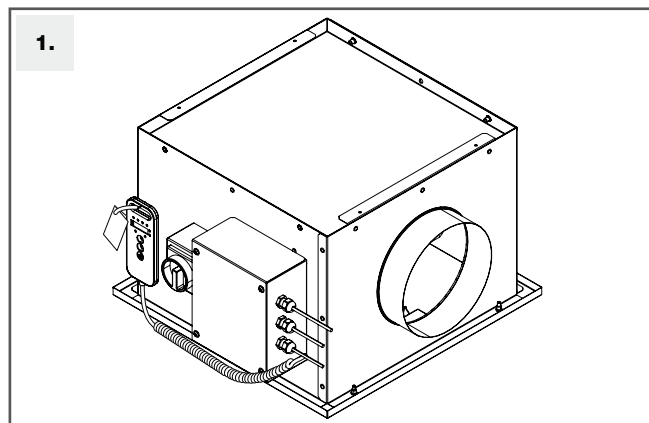

**3. PRÉCONISATIONS AVANT MONTAGE • RECOMMENDATIONS PRIOR TO ASSEMBLY • EMPFEHLUNG VOR MONTAGE • MONTAGEVOORSCHRIFTEN • RECOMENDACIONES ANTES DEL MONTAJE • RACCOMANDAZIONI PRIMA DEL MONTAGGIO**

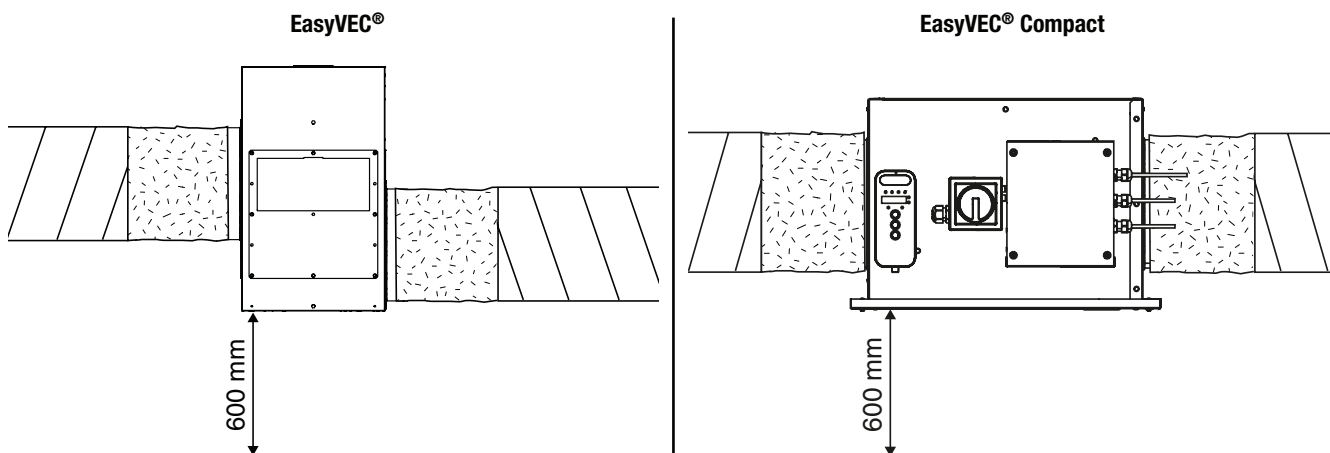

**4. MONTAGE • ASSEMBLY • EINBAU • MONTAGE • MONTAJE • MONTAGGIO**

**4.1. Consignes de sécurité • Safety instructions • Sicherheitshinweise • Veiligheidsinstructies • Consignas de seguridad • Istruzioni di sicurezza**

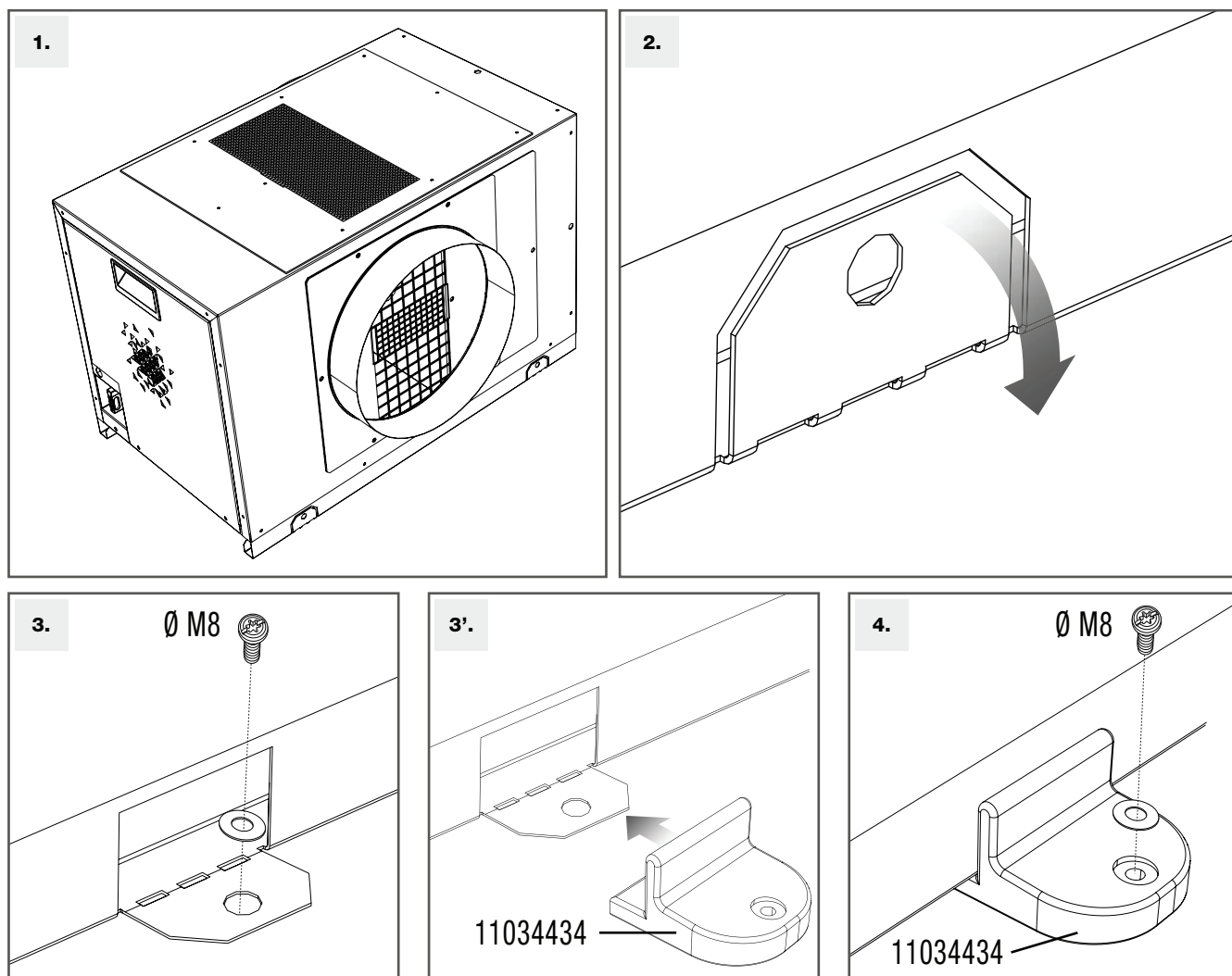

EasyVEC®

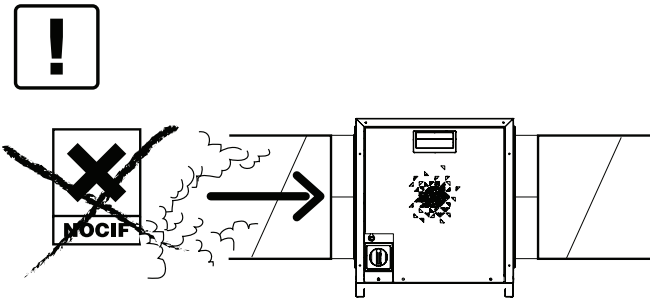
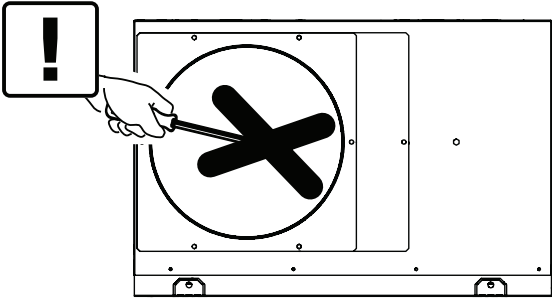
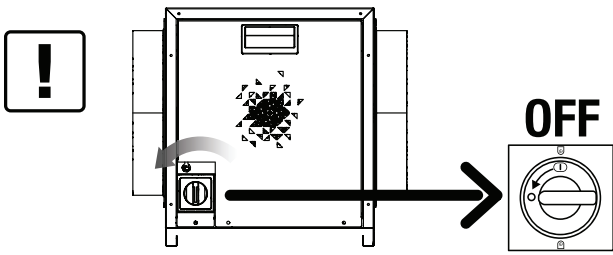

EasyVEC® Compact

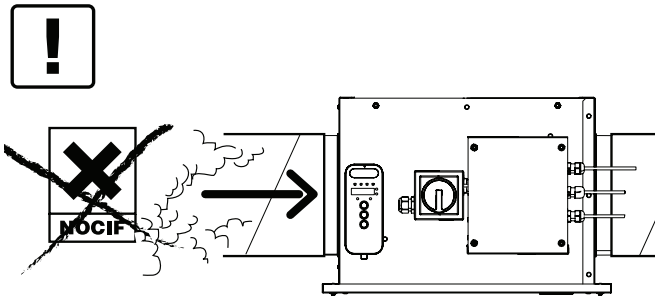
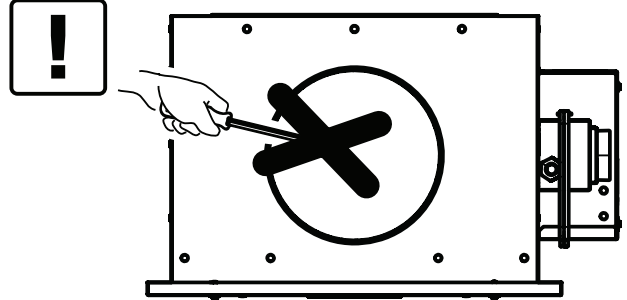
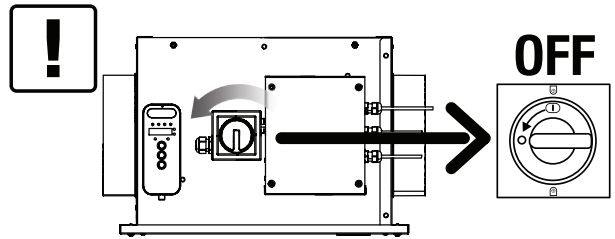

4.2. Raccordements aérauliques • Air duct connections • Lufttechnische Anschlüsse • Aansluiting van luchtkanalen • Conexiones aeráulicas • Raccordi aeraulici

EasyVEC® C4 300

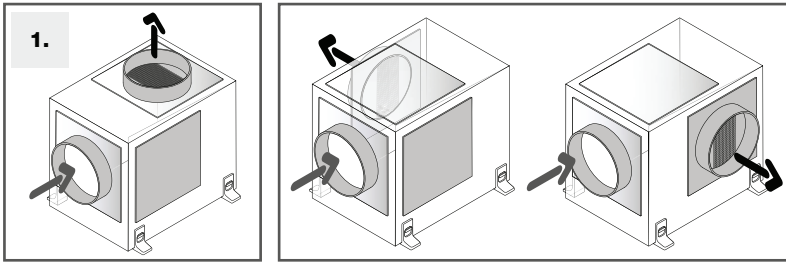

EasyVEC® C4 & EasyVEC®

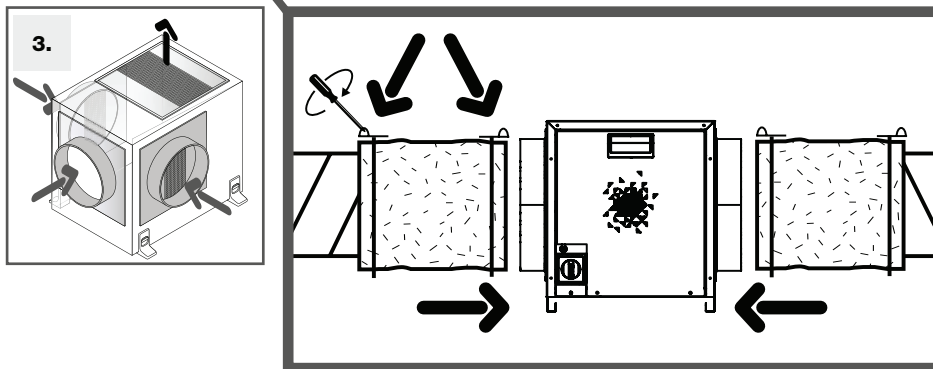
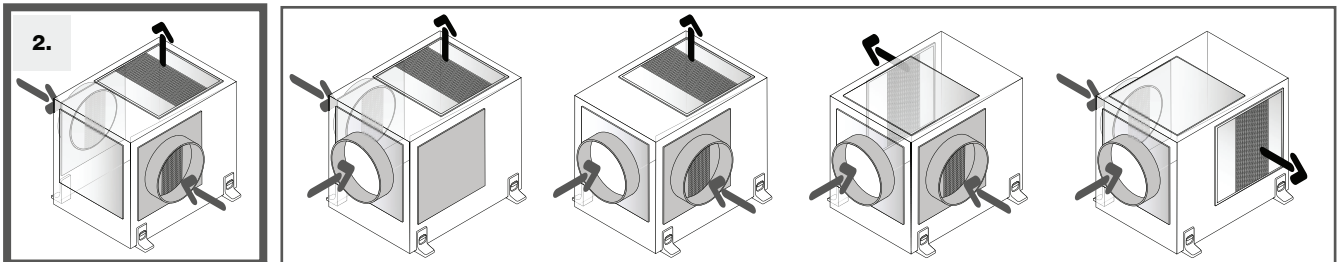
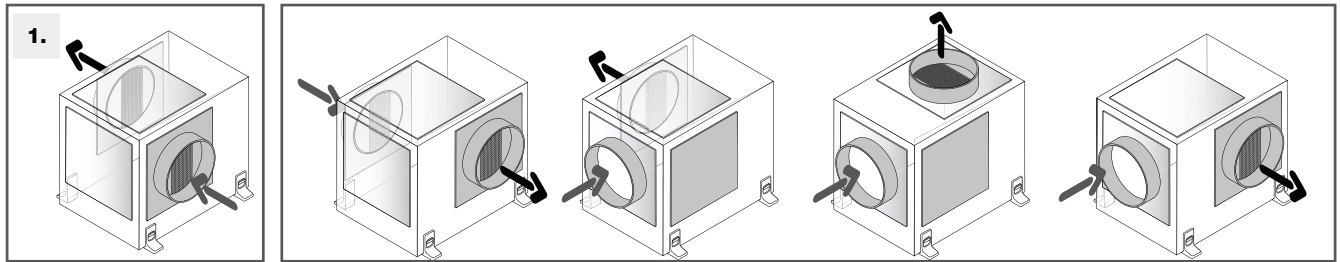

EasyVEC® Compact

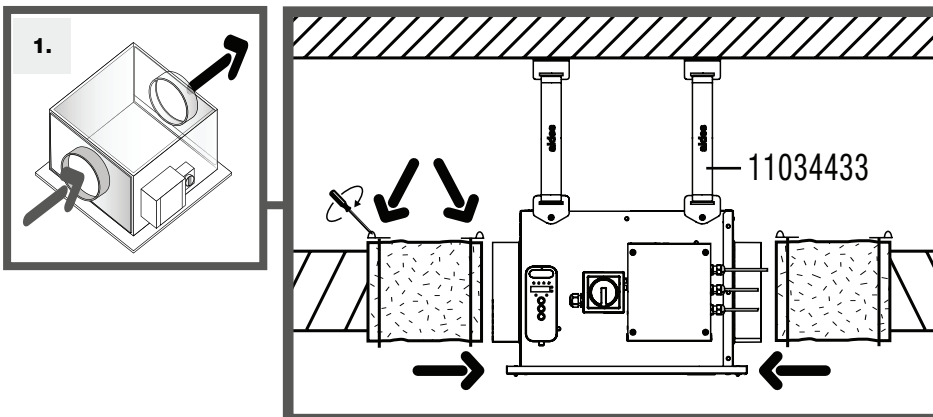

4.3. Raccordements électriques • Electrical connections • Elektroanschlüsse • Elektrische aansluitingen • Conexiones eléctricas • Connessioni elettriche

EasyVEC®

EasyVEC® Compact

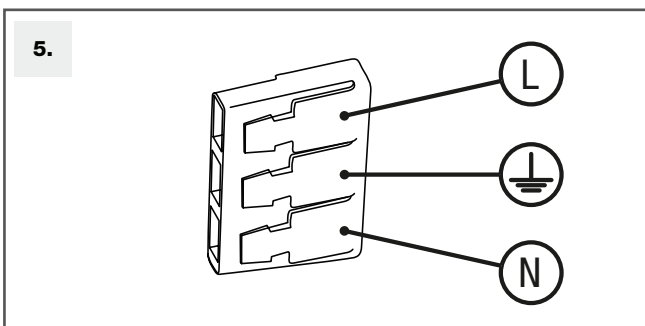
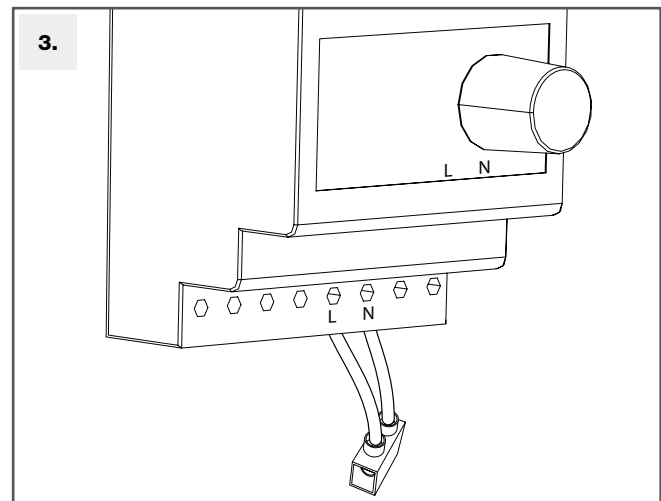
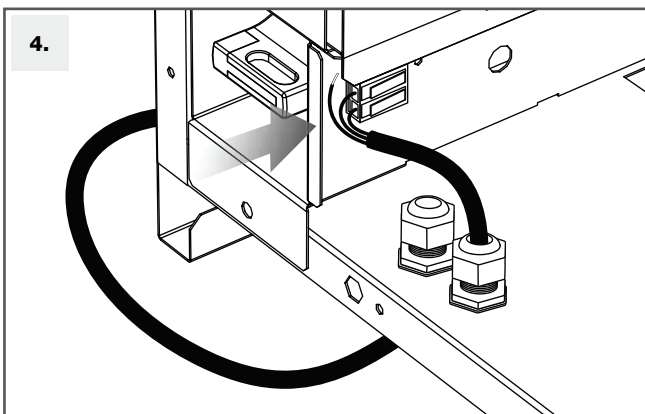
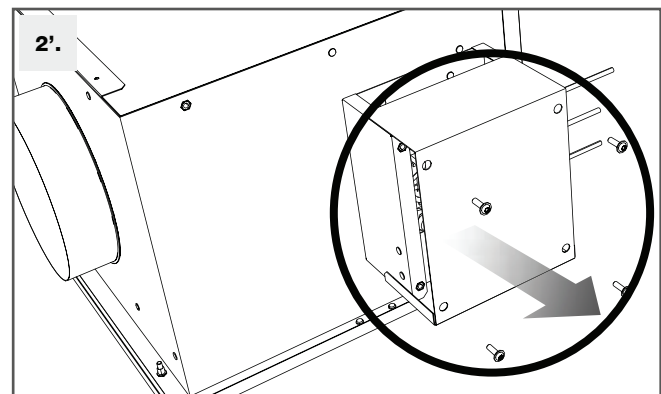
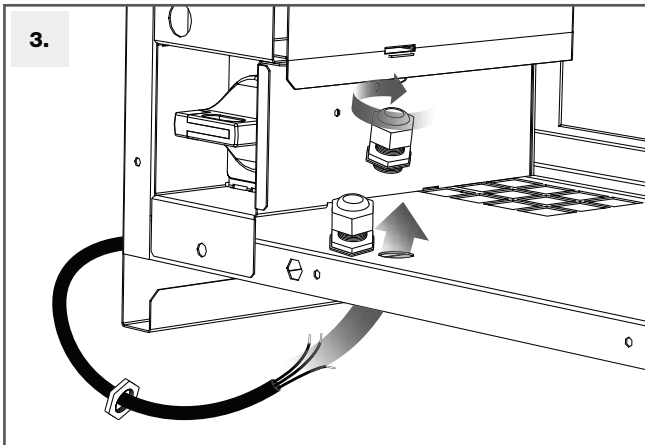
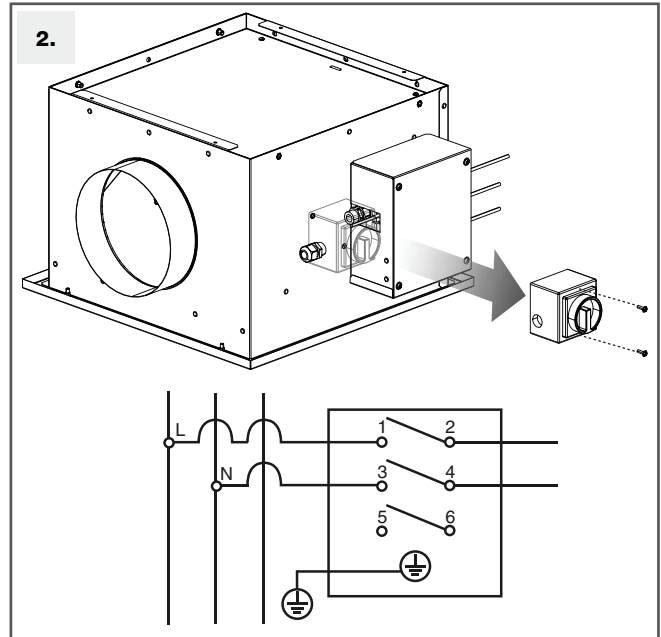
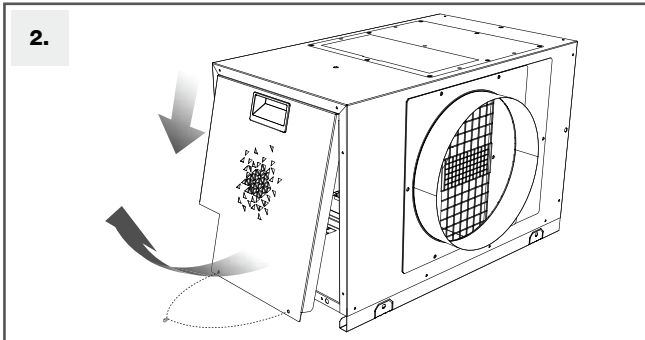
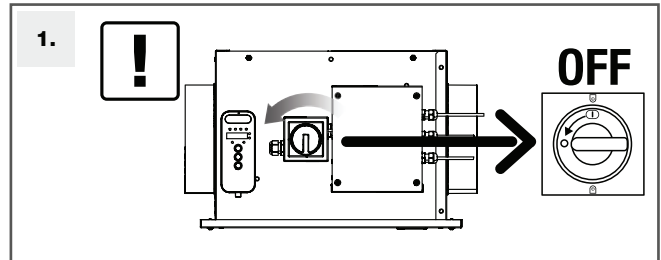
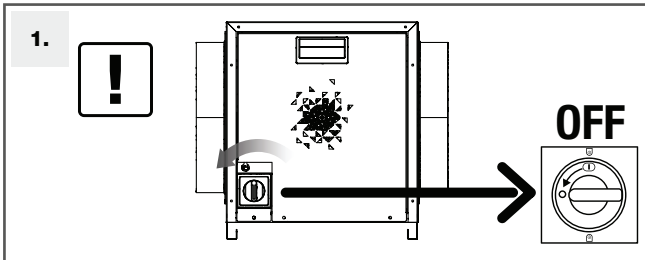

**6. Thermo Contact hors/except MW, MW+**

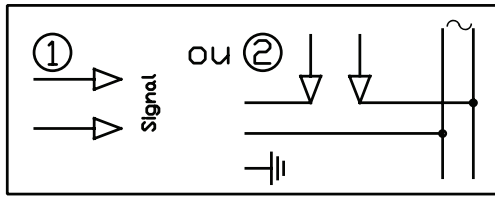

FR	GB	DE	NL	ES	IT
Marron	Brown	Braun	Bruin	Marrón	Marrone
Rouge	Red	Rot	Rood	Rojo	Rosso
Bleu	Blue	Blau	Blauw	Azul	Blu
GV = Vitesse élevée	GV = High speed	GV =	GV =	GV =	GV =
MV = Vitesse moyenne	MV = Medium speed	MV =	MV =	MV =	MV =
PV = Vitesse basse	PV = Low speed	PV =	PV =	PV =	PV =

**4.4. Raccordement télécommande • Remote control connection • Fernbedienungsanschluss • Aansluiting afstandsbediening • Conexión telecomando • Raccordo telecomando**

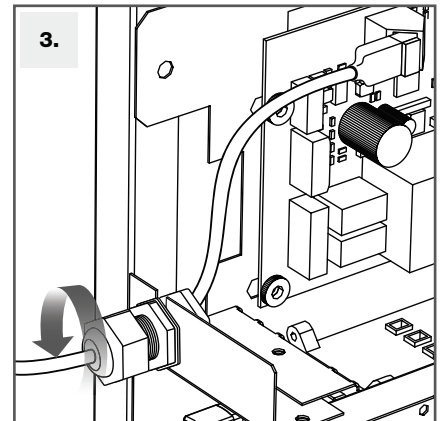
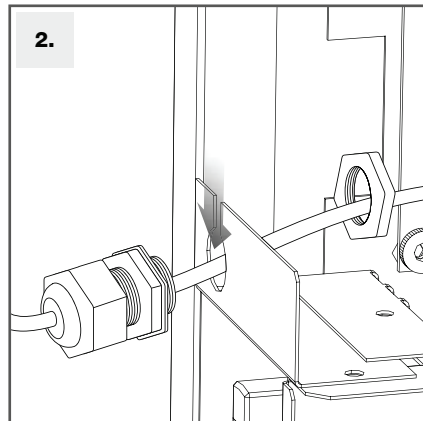
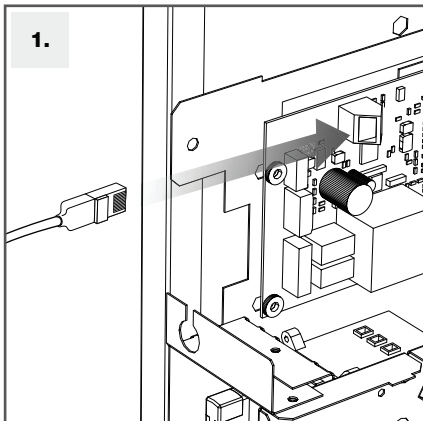

# 5. MISE EN SERVICE • ACTIVATION • INBETRIEBNAHME • INBEDRIJFSTELLING • PUESTA EN SERVICIO • MESSA IN SERVIZIO

## 5.1. Opérations de mise en service • Activation operations • Inbetriebnahmearbeiten • Uit te voeren taken voor de ingebruikneming • Operaciones de puesta en servicio • Operazioni di messa in servizio

### EasyVEC®

#### 1. EasyVEC® C4 300 / 700 mono-débit

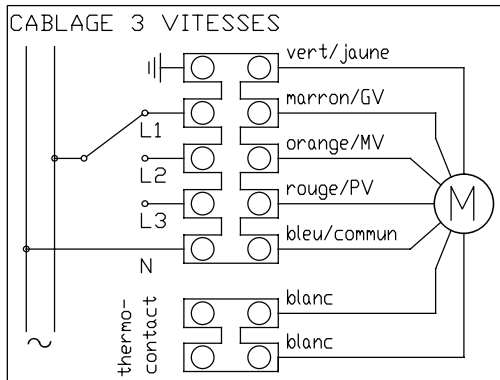

#### 1'. EasyVEC® C4 300 / 700 / 1000 / 1500 / 2000 / 2500 EasyVEC® 1000 / 1500 / 2000 / 2500

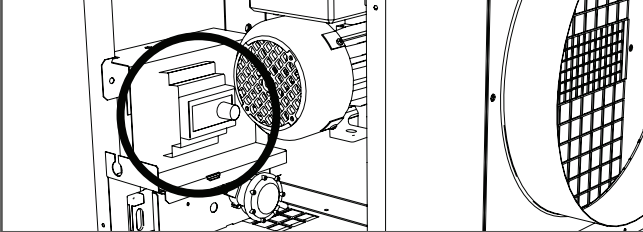

#### 2. EasyVEC® 1000 / 1500 / 2000 / 2500

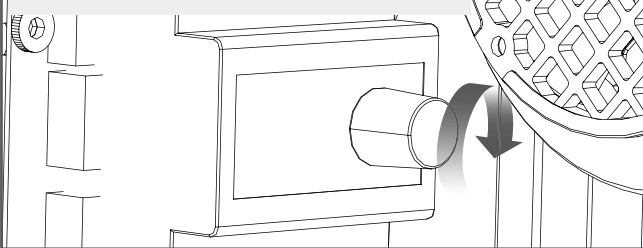

#### 2'. EasyVEC® C4 300 / 700 / 1000 / 1500 / 2000 / 2500

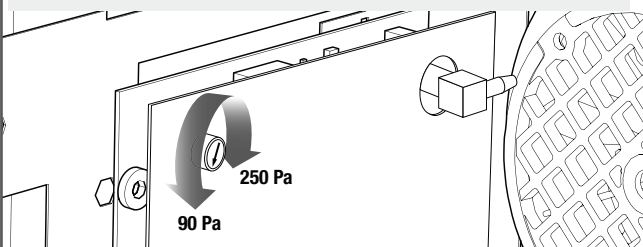

#### 3.

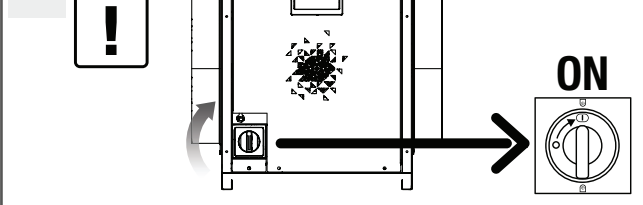

### EasyVEC® Compact

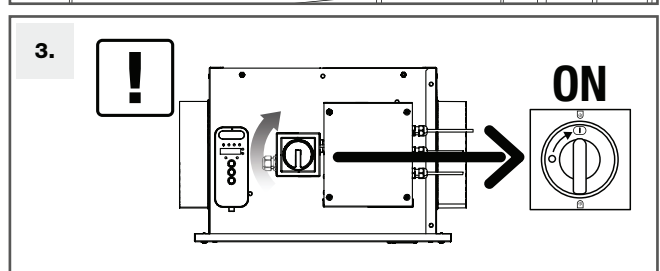
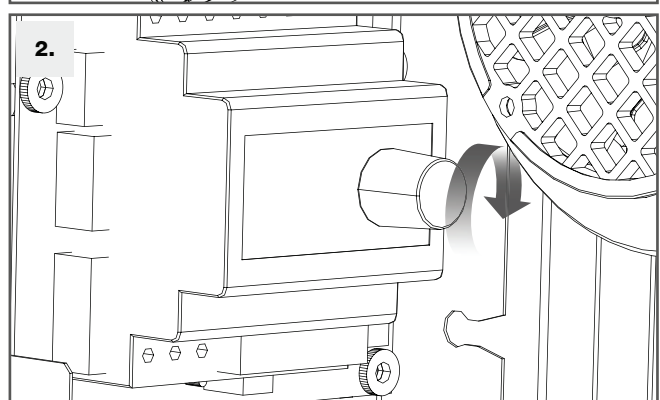
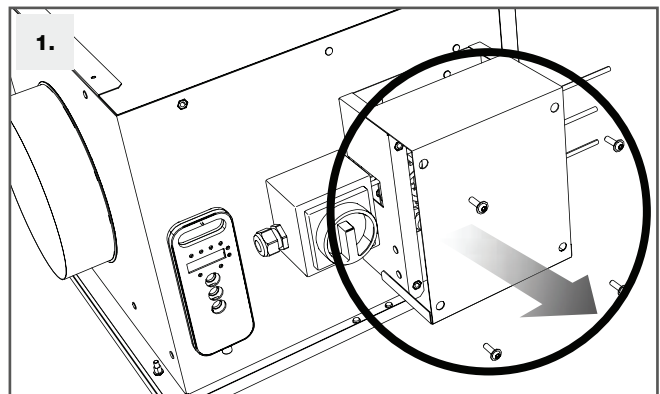



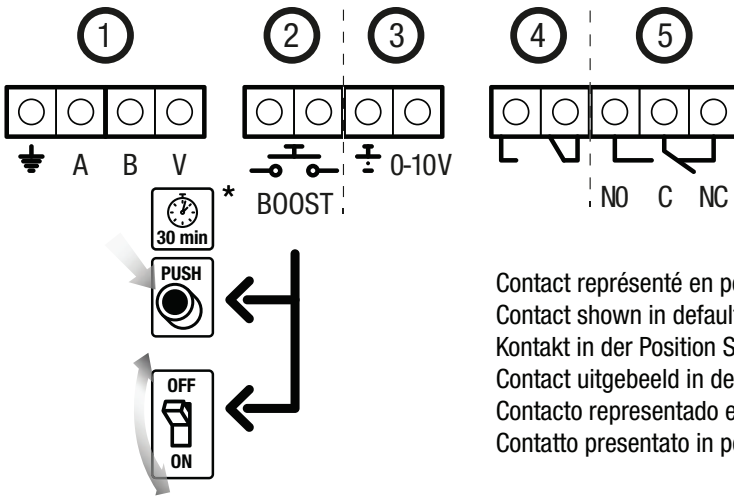
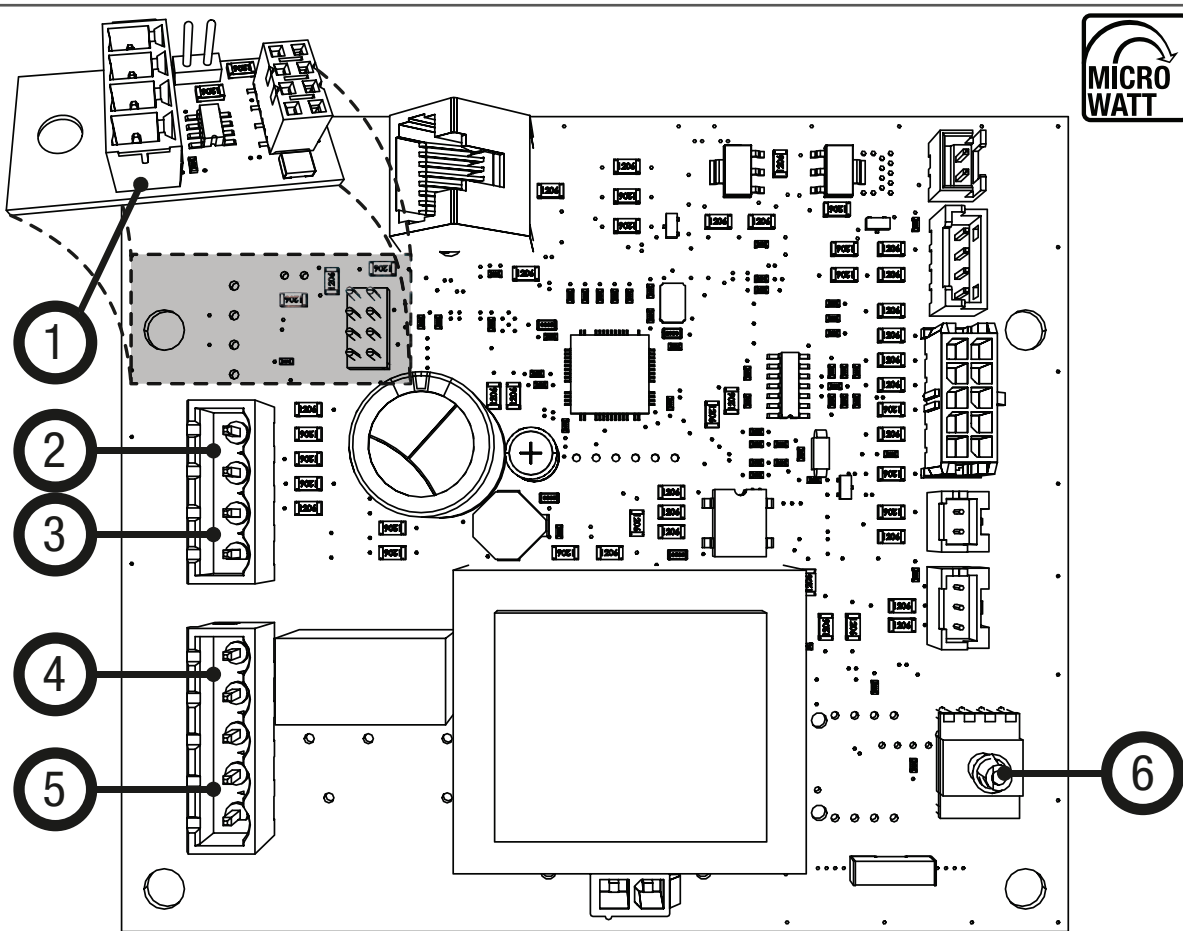

Contact représenté en position défaut/hors tension  
 Contact shown in default/de-energized position  
 Kontakt in der Position Störung/Aus dargestellt  
 Contacto representado en posición defecto/sin tensión  
 Contatto presentato in posizione guasto/fuori tensione

	FR	GB	DE	NL	ES	IT
1	Modbus	Modbus	Modbus	Modbus	Modbus	Modbus
2	Entrée Boost	Boost input	Eingang Boost	Ingang Boost	Entrada Boost	Ingresso Boost
3	Entrée 0-10 V	0-10 V input	Eingang 0-10 V	Ingang 0-10 V	Entrada 0-10 V	Ingresso 0-10 V
4	Indicateur de changement de filtre Relais 5A	Filter change lamp 5A Relay	Filterwechselanzeige Relais 5A	Filtervervangingsindicator Relais 5A	Indicador de cambio de filtro Relé 5 A	Indicatore di sostituzione filtro Relè 5A
5	Signal défaut Relais 5A	Fault signal 5A Relay	Störungssignal Relais 5A	Storingssignaal Relais 5A	Señal defecto Relé 5 A	Segnale guasto Relè 5A
6	Captur de dépression	Pressure loss sensor	Unterdrucksensor	Onderdruksensor	Captador de depresión	Sensore di depressione

\* durée réglable voir 6.3 / Adjustable duration, see 6.3 / einstellbare Dauer, siehe 6.3 / regelbare duur, zie 6.3 / duración regulable, ver 6.3 / durata regolabile, vedere 6.3

5.2. Paramétrage Télécommande • Remote control configuration • Fernbedienungsparametrierung • Instelling afstandsbediening • Parametrización telecomando • Impostazioni telecomando

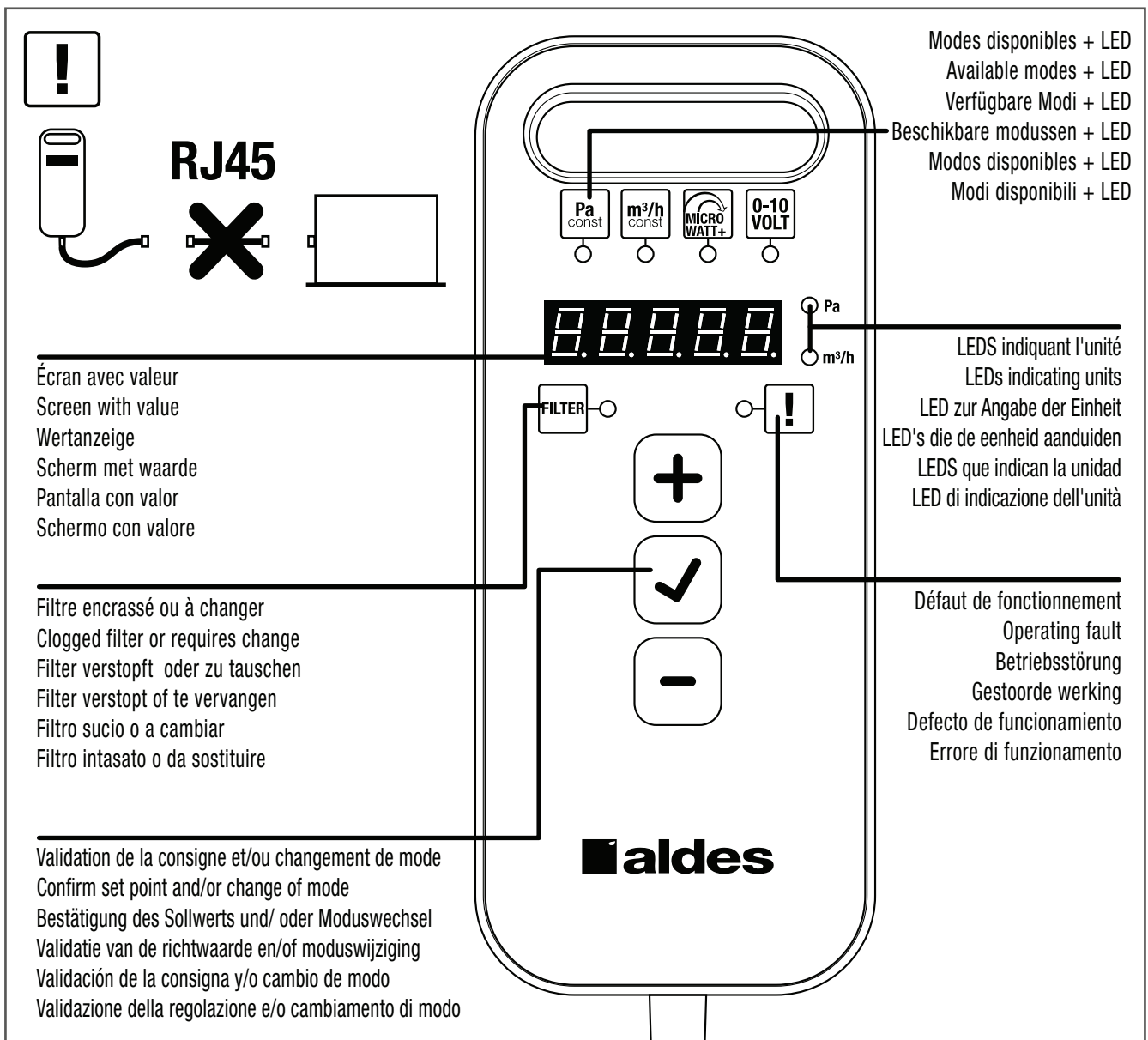

## 6. MODE DE FONCTIONNEMENT • OPERATING MODE • BETRIEBZUSTAND • WERKSTAND • MODO DE FUNCIONAMIENTO • MODO OPERATIVO

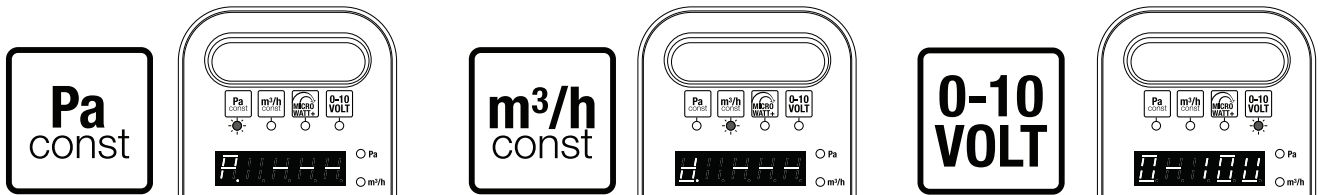

**FR** Pression constante  
extraction ou soufflage

**GB** Constant pressure  
exhaust or supply

**DE** Konstanter Druck  
Abluft oder Gebläse

**NL** Constante druk  
afzuigen of inblazen

**ES** Presión constante  
extracción o soplado

**IT** Pressione costante  
estrazione o soffiaggio

**FR** Débit constant

**GB** Constant airflow

**DE** Konstante Fördermenge

**NL** Constant debiet

**ES** Caudal constante

**IT** Portata costante

**FR** Pilotage 0-10 V

**GB** Control via 0-10 V signal

**DE** Steuerung 0-10 V

**NL** Aansturing 0-10 V

**ES** Pilotaje 0-10 V

**IT** Gestione 0-10 V

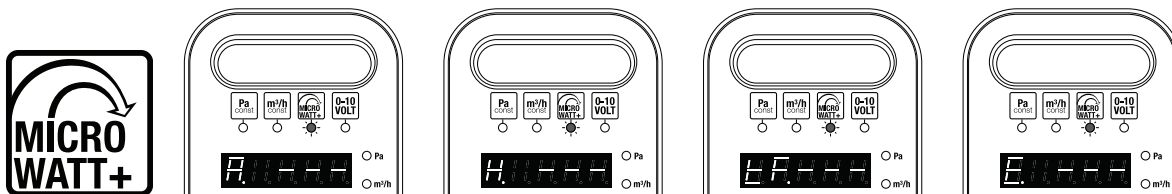

**FR** Pression réglée  
(autoréglable, hygroréglable, T.Flow et expert)

**GB** Controlled pressure  
(self-balanced, humidity-controlled, T.Flow and Expert)

**DE** Geregelter Druck  
(selbstgeregelt, feuchtigkeitsgeregelter, T.Flow und Experte)

**NL** Gereguleerde druk  
(automatisch, hygroregelbaar, T.Flow en expert)

**ES** Presión regulada  
(autorregulación, higrorregulable, T.Flow y experto)

**IT** Pressione regolata  
(autoregolabile, igroregolabile, T.Flow e expert)

6.1. Menu paramétrage • Configuration menu • Parametrierungsmenü • Setup-menu • Menú parametrización • Menu impostazioni

**MICRO-WATT**

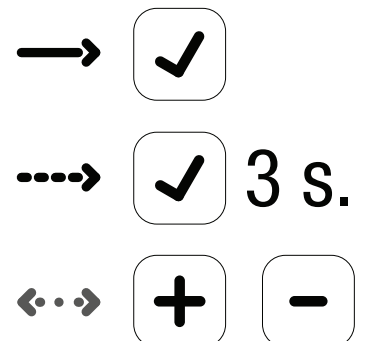
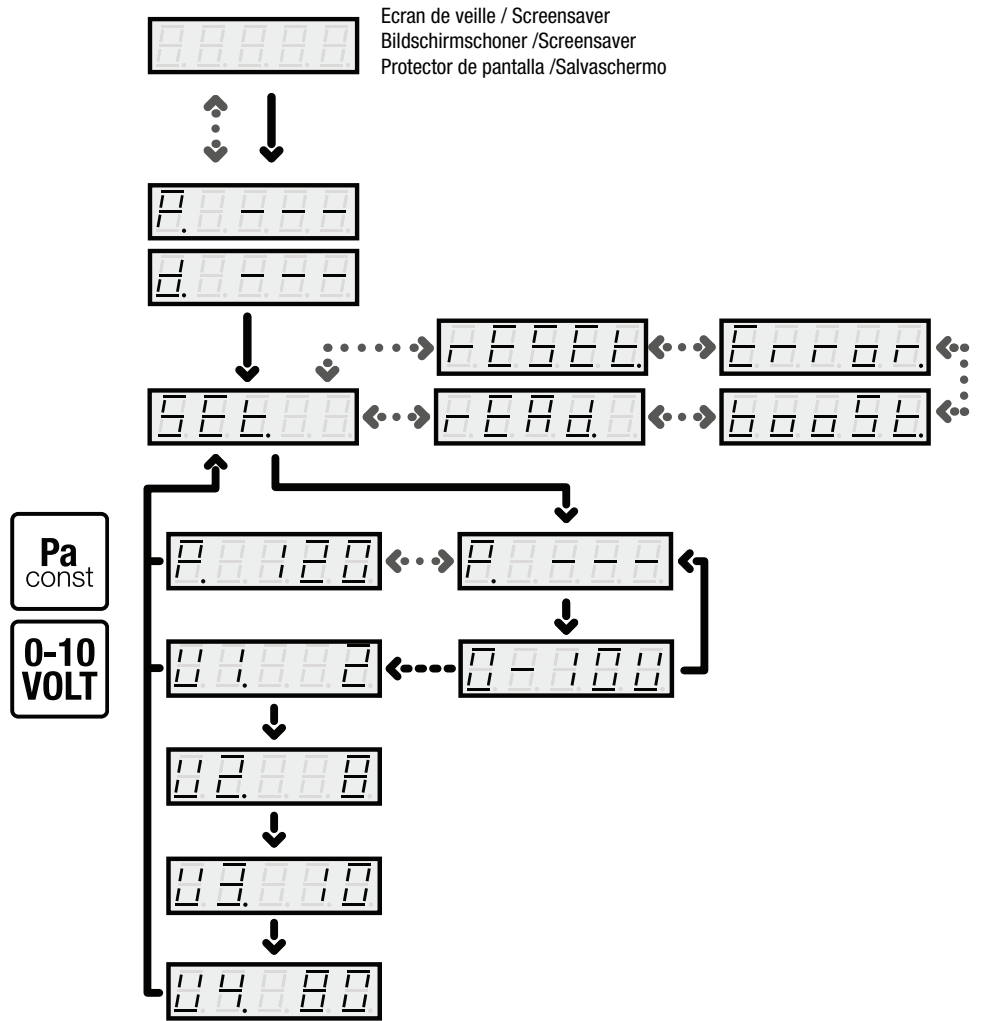

# MICRO-WATT +



Ecran de veille / Screensaver  
Bildschirmschoner / Screensaver  
Protector de pantalla / Salvaschermo

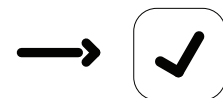
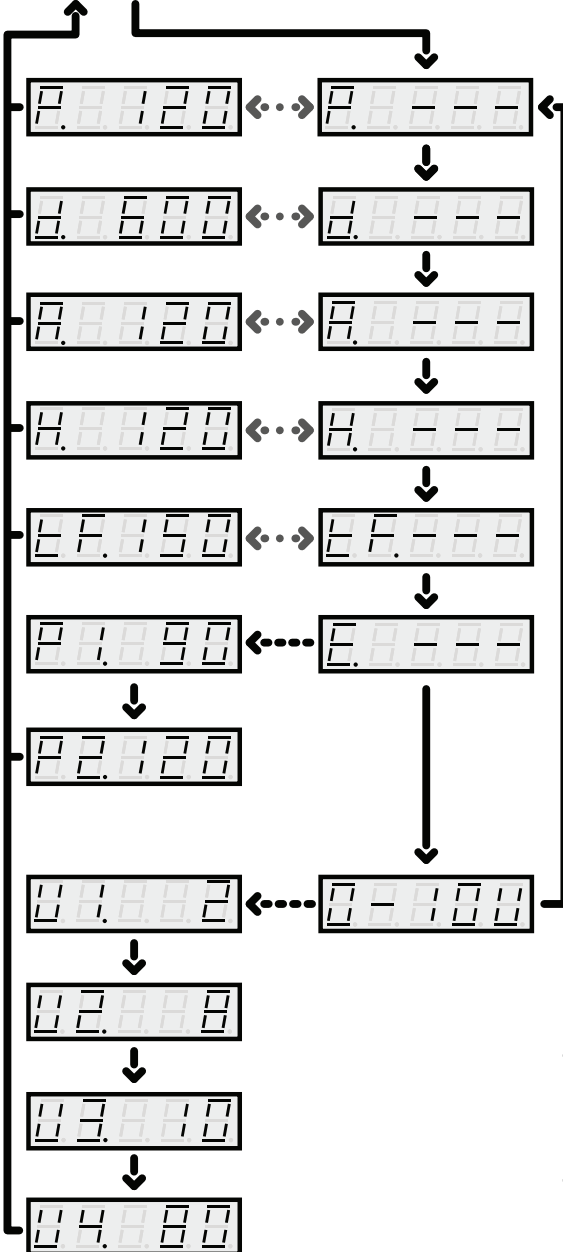

6.2. Visualisation des valeurs de fonctionnement • Display operating values • Anzeige der Betriebswerte • Bedrijfswaarden weergeven • Visualización de los valores de funcionamiento • Visualizzazione dei valori operativi

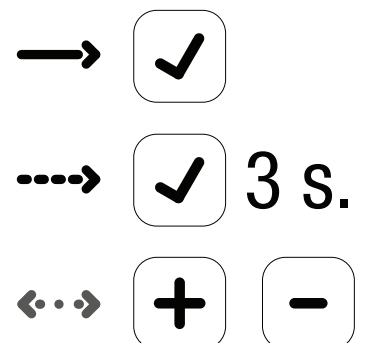
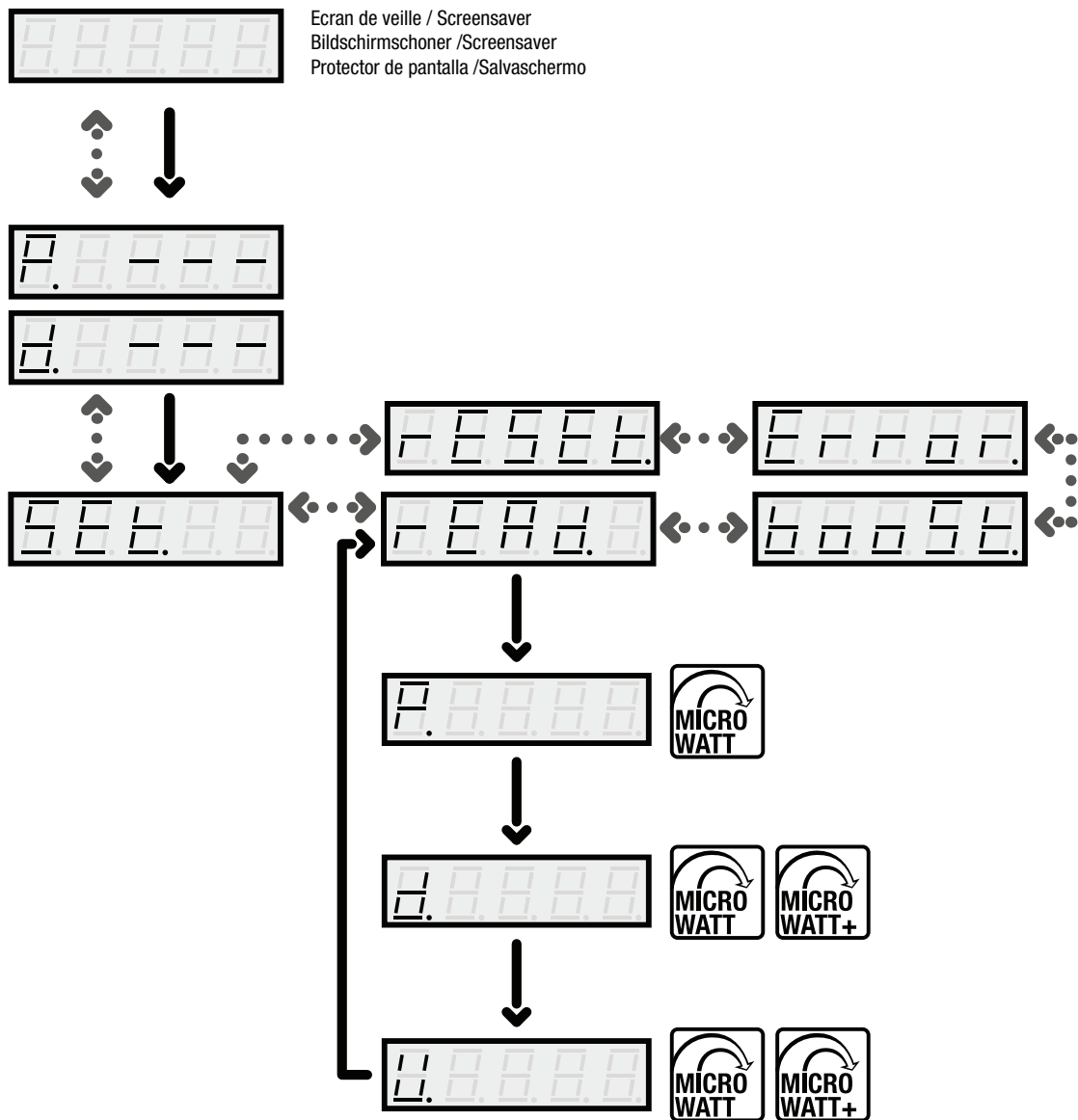



6.4. Remise à zéro • Reset to Zero • Rücksetzen • Resetten • Puesta a cero • Reset

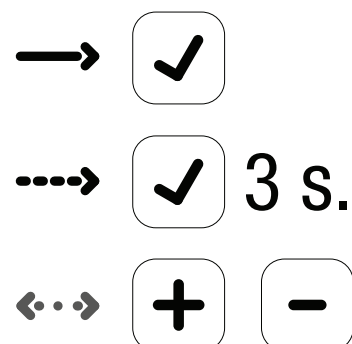
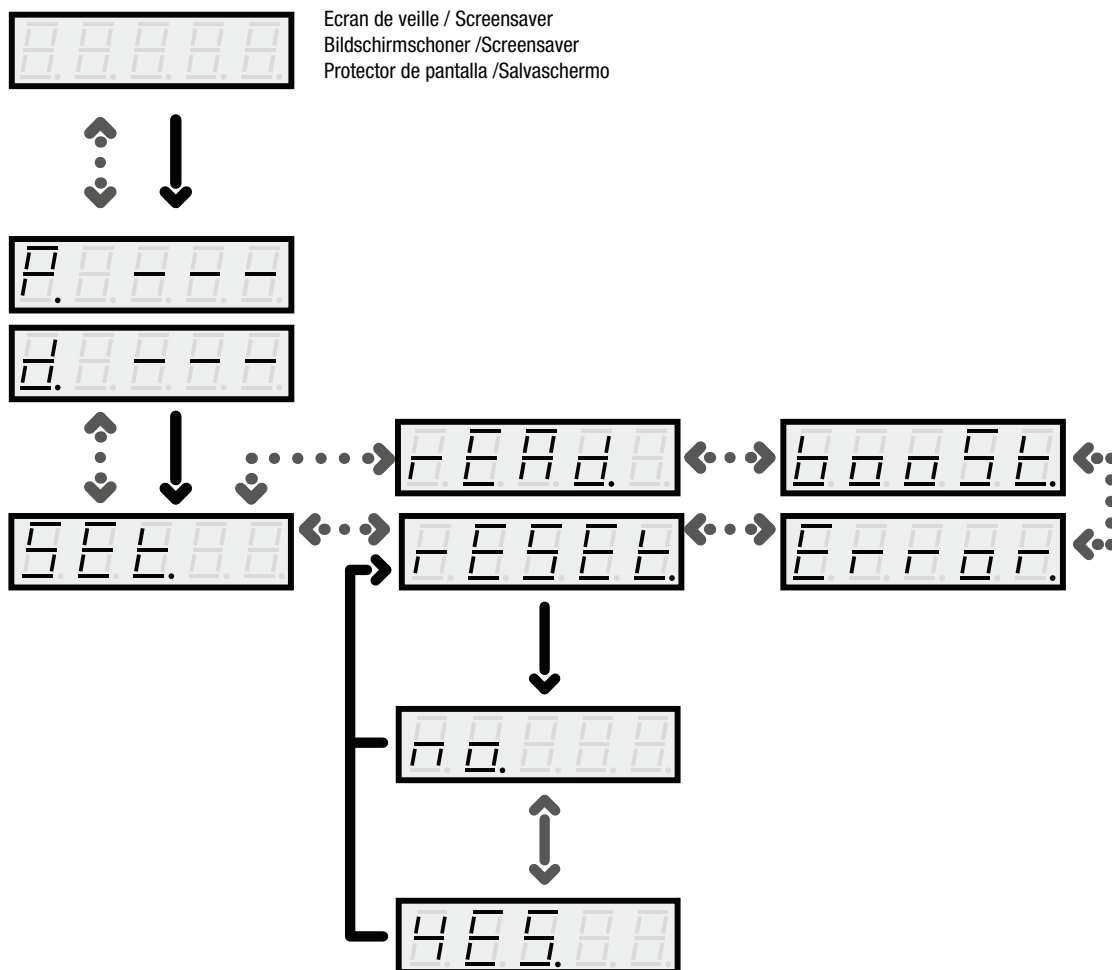









## 6.6. Contrôles et essais • Tests and trials • Prüfungen und Versuche • Controles en tests • Controles y pruebas • Controlli e test

FR





Symptôme 1	Symptôme 2	Vérifications	Action
Un défaut s'affiche sur la télécommande		- Se reporter au tableau des codes erreur ci-dessous	
Le ventilateur ne démarre pas	L'écran de la télécommande (selon version) est allumé	- Contrôler l'ensemble des câblages. - Contrôler le moteur : l'alimenter en direct 230V~. appliquer une commande de marche au moteur	Remplacer la pièce incriminée : carte électronique de commande ou moteur
	L'écran de la télécommande (selon version) est éteint	- Contrôler l'ensemble des câblages. - Contrôler le fusible sur carte électronique de commande.	Remplacer la pièce incriminée : télécommande ou carte électronique de commande.
	Version sans télécommande	- Contrôler l'ensemble des câblages - Contrôler le condensateur (selon version). - Contrôler le fusible du variateur de vitesse. - Contrôler la tension de sortie du variateur de vitesse (selon version) - Contrôler le moteur : l'alimenter en direct 230V~. De plus, sur moteur EC (EasyVEC® Compact 2000) : appliquer une commande de marche au moteur	Remplacer la pièce incriminée : fusible, condensateur, variateur de vitesse ou moteur
Le ventilateur démarre puis s'arrête		- Contrôler l'ensemble des câblages.	
Le ventilateur ne fonctionne pas à la consigne réglée	Vitesse faible	- Vérifier que la roue ne frotte pas. - Contrôler le condensateur (selon version). - Régler le variateur de vitesse (selon version). - Contrôler la tension de sortie du variateur de vitesse ou de la carte électronique de commande (selon version). - Contrôler la fonctionnalité du ou des capteurs de pression (selon version), en simulant une légère surpression ou dépression dans les tubes de pression. - Contrôler le moteur : l'alimenter en direct 230V~. De plus, sur moteur EC (EasyVEC® Compact 2000 et versions micro-watt et micro-watt +) : appliquer une commande de marche au moteur (contacter l'Assistance Technique).	Remplacer la pièce incriminée : condensateur, capteur de pression additionnel (version micro-watt +), variateur de vitesse, carte électronique de commande ou moteur
	Vitesse élevée	- Contrôler le thermocontact de déclenchement de mode incendie, et son câblage (selon version) - Contrôler l'état, la position et la bonne connexion des tubes de pression (selon version), les déboucher. - Contrôler les points ci-dessus (vitesse faible)	Remplacer la pièce incriminée : thermocontact (de déclenchement mode incendie). Voir ci-dessus (vitesse faible)
	La vitesse ne varie pas lors d'une variation de consigne	- Contrôler le réseau aérialuque à la recherche de fuite. - Contrôler les points ci-dessus (vitesse élevée, vitesse faible)	Voir ci-dessus (vitesse élevée, vitesse faible)
Le ventilateur tourne en sens inverse		- Contrôler le câblage dans la boîte à bornes du moteur (EasyVEC® 1000 à 2500)	
Les modes micro-watt + et débit constant ne sont plus disponibles (version micro-watt +)		- Contrôler le câblage du capteur de pression additionnel (version micro-watt +).	Changer le capteur de pression additionnel (version micro-watt +).

N°	Signification	Diagnostic / Solutions
E.50	Retour de vitesse moteur = 0 tr/min	Moteur déconnecté ou rotor bloqué ou moteur hors service
E.51	Retour de vitesse moteur <100 tr/min	La roue frotte ou moteur hors service
E.52	Le ventilateur n'atteint pas le seuil de pression minimum.	Contrôler le système complet (fuites et pertes de charge réseau) Contrôler l'état et la bonne connexion des capillaires, les déboucher.
		Pression constante : 80 Pa.
		Pression régulée autoréglable : 50 Pa.
		Pression régulée hygroréglable : 80 Pa.
		Pression régulée T.Flow : 110 Pa.
	Débit constant : NA.	
	Pilotage 0-10 V : NA.	
E.53	Pression mesurée incohérente (trop haute)	Capteur de pression hors service
E.88	Défaut de communication avec la télécommande	Télécommande hors service
E.251	Fonctionnement en mode incendie, circuit du thermocontact ouvert	Le câblage du thermocontact ou le thermocontact lui-même sont hors service

Tous ces numéros d'erreur disparaissent après résolution de l'anomalie et de la remise à zéro (voir 6.4).





En cas de problème vous pouvez faire une réinitialisation totale (reset : voir 6.4) et si le problème persiste, consulter notre SAV.

Symptom 1	Symptom 2	Verifications	Action
A fault is displayed on the remote control		- See error code table below	
The fan unit will not start	The remote control screen (depending on version) is switched on	- Check all wiring - Check the motor: must be supplied directly with 230V~. Activate the motor run control	Replace the faulty part: Control PCB or motor
	The remote control screen (depending on version) is switched off	- Check all wiring. - Check fuse on Control PCB	Replace the fault part: remote control or Control PCB.
	Version without remote control	- Check all wiring - Check capacitor (depending on version) - Check speed controller fuse - Check voltage at the output of the speed controller (depending on version) - Check the motor: 230V AC direct supply. In addition, for EC motors (EasyVEC® Compact 2000): activate the motor run control	Replace the faulty part: fuse, capacitor, speed controller or motor
The fan unit starts and then stops		- Check all wiring.	
The fan does not run at the selected set-point	Low speed	"Check that the impeller is not rubbing against the casing - Check the capacitor (depending on version). - Adjust the speed controller (depending on version). - Check the output voltage from the speed controller or Control PCB (depending on version). - Check the functioning of the pressure sensor(s) (depending on version, simulating a slight over or under pressure in the pressure tubes. - Check the motor: Directly from 230V AC supply In addition, for EC motors (EasyVEC® Compact 2000 & micro-watt/micro-watt + versions): activate the motor run control (contact Technical Support)"	Replace the faulty part: capacitor, additional pressure sensor (micro-watt + version), speed controller, electronic control PCB or motor
	High speed	- Check the fire mode thermo-trip device and wiring (depending on version) - Check the condition, position and connectivity of pressure tubes (depending on version), unblock if necessary. - Check the above points (low speed).	Replace the faulty part: thermo-trip device (triggering fire mode). See above (low speed)
	The speed does not change when the set point is changed	- Inspect the aerualic network looking for leaks. - Check the above points (high speed - low speed)	- See A45 above (high speed - low speed)
The fan rotates in the wrong direction		- Check the wiring in the motor terminal unit (EasyVEC® 1000 to 2500)	
The micro-watt+ and constant flow rate modes are no longer available (micro-watt+ version)		- Check the wiring on the additional pressure sensor (micro-watt+ version)	Change the additional pressure sensor (micro-watt+ version)

N°	Meaning	Diagnostics/Solutions	
E.50	Motor speed return = 0 rpm	Motor disconnected or fan stuck or motor U/S	
E.51	Motor speed return < 100 rpm	Fan is rubbing or motor is U/S	
E.52	Fan does not reach minimum pressure set point	Check full system (network load and loss through leakage) Check the state and connectivity of capillaries, unblock if necessary.	
		Constant pressure: 80 Pa.	
		Self-balanced regulated pressure: 50 Pa	
		Humidity-controlled regulated pressure: 80 Pa	
		T-Flow regulated pressure: 110 Pa	
		Expert regulated pressure: 50 Pa	
	Constant airflow: NA		
	Control 0-10 V: NA		
E.53	Incoherent pressure reading (too high)	Pressure sensor U/S	
E.88	Communications fault involving remote control	Remote control U/S	
E.251	Operating in Fire Mode, thermo-contact circuit open	Thermocontact circuit or thermocontact U/S	

All these error numbers disappear when the fault is resolved and reset (See 6.4).  
 In the event of a problem, you may carry out a total system reset (Reset: See 6.4) and if the problem persists, contact our After Sales Service Dept.).





Symptom 1	Symptom 2	Überprüfungen	Aktion
Auf der Fernbedienung wird eine Störung angezeigt		- Siehe in der folgenden Tabelle mit den Fehlercodes	
Der Ventilator startet nicht	Der Bildschirm der Fernbedienung (je nach Version) ist eingeschaltet	- Sämtliche Verdrahtungen überprüfen. - Den Motor überprüfen: direkt mit 230V~ versorgen. Einen Einschaltbefehl auf den Motor anwenden	Das beschuldigte Teil austauschen: Steuerkarte oder Motor
	Der Bildschirm der Fernbedienung (je nach Version) ist ausgeschaltet	- Sämtliche Verdrahtungen überprüfen. - Die Sicherung auf der Steuerkarte überprüfen.	Das beschuldigte Teil austauschen: Fernbedienung oder Steuerkarte
	Version ohne Fernbedienung	- Sämtliche Verdrahtungen überprüfen - Den Kondensator überprüfen (je nach Version). - Die Sicherung des Geschwindigkeitsreglers überprüfen. - Die Ausgangsspannung des Geschwindigkeitsreglers überprüfen (je nach Version) - Den Motor überprüfen: direkt mit 230V~ versorgen. Darüber hinaus am EC Motor (EasyVEC® Compact 2000): einen Einschaltbefehl auf den Motor anwenden	Das beschuldigte Teil austauschen: Sicherung, Kondensator, Geschwindigkeitsregler oder Motor
Der Ventilator startet und hält wieder an		- Sämtliche Verdrahtungen überprüfen.	
Der Ventilator läuft nicht entsprechend den eingestellten Vorgaben	Geringe Geschwindigkeit	- Überprüfen, ob das Rad scheuert. - Den Kondensator überprüfen (je nach Version). - Den Geschwindigkeitsregler einstellen (je nach Version). - Die Ausgangsspannung am Geschwindigkeitsregler oder an der Steuerkarte überprüfen (je nach Version). - Prüfen, ob der oder die Druckschalter (je nach Version) funktionieren, indem man einen leichten Überdruck oder Unterdruck in den Druckrohren simuliert. - Den Motor kontrollieren: direkt mit 230V~ versorgen. Darüber hinaus am EC Motor (EasyVEC® Compact 2000 und die Versionen micro-watt und micro-watt +): einen Einschaltbefehl auf den Motor anwenden (sich an den technischen Dienst wenden)	Das beschuldigte Teil austauschen: Kondensator, zusätzlicher Druckschalter (Version micro-watt +), Geschwindigkeitsregler, Steuerkarte oder Motor
	Hohe Drehzahl	- Den Thermoventilator zum Auslösen des Brandmodus, sowie dessen Verdrahtung (je nach Version) überprüfen - Den Zustand, die Position und den korrekten Anschluss der Druckrohre (je nach Version) überprüfen, reinigen. - Die oben genannten Punkte überprüfen (geringe Drehzahl)"	Das beschuldigte Teil austauschen: Thermoventilator (zum Auslösen des Brandmodus). Siehe oben (geringe Drehzahl)
	Die Drehzahl ändert sich bei einer geänderten Vorgabe nicht	- Das lufttechnische Netz auf Lecks untersuchen. - Die oben genannten Punkte überprüfen (erhöhte Drehzahl, geringe Drehzahl)	Siehe oben (erhöhte Drehzahl, geringe Drehzahl)
Der Ventilator dreht sich in die falsche Richtung		- Die Verdrahtung im Klemmenkasten des Motors (EasyVEC® 1000 bis 2500) überprüfen	
Die Modi micro-watt + und konstante Leistung stehen nicht mehr zur Verfügung (Version micro-watt +)		- Die Verdrahtung des zusätzlichen Druckschalters (Version micro-watt +) überprüfen	Den zusätzlichen Druckschalter (Version micro-watt +) überprüfen

N°	Bedeutung	Diagnose / Lösungen
E.50	Rückmeldung der Motordrehzahl = 0 U/min	Motor abgesteckt oder Rotor blockiert oder Moto ausgeschaltet
E.51	Rückmeldung der Motordrehzahl < 100 U/min	Das Rad scheuert oder Motor ausgeschaltet
E.52	Der Ventilator erreicht den Mindestdruck-Grenzwert nicht	Das gesamte System überprüfe (Lecks oder Druckverluste im Netzwerk) Den Zustand und den korrekten Anschluss der Kapillaren überprüfen, reinigen.
		Konstanter Druck: 80 Pa.
		Selbstregelnder eingestellter Druck: 50 Pa
		Feuchtigkeitsgeregelter eingestellter Druck: 80 Pa
		Eingestellter Druck T.Flow: 110 Pa Eingestellter Druck Experte: 50 Pa
	Konstante Leistung: NZ	
	Steuerung 0-10 V: NZ	
E.53	Inkohärenter gemessener Druck (zu hoch)	Druckschalter nicht in Betrieb
E.88	Kommunikationsstörung mit der Fernbedienung	Fernbedienung ausgeschaltet
E.251	Betrieb im Brandmodus, Thermoventilatorkreis offen	Die Verdrahtung des Thermoventilators oder der Thermoventilator selbst sind nicht in Betrieb

Alle Fehlernummern verschwinden nach der Lösung der Anomalie und nach dem Zurücksetzen (siehe 6.4).

Im Problemfall können Sie das System vollständig zurücksetzen (Reset: siehe 6.4) und falls das Problem weiter bestehen bleibt, wenden Sie sich bitte an unseren Kundendienst.





Verschijnsel 1	Verschijnsel 2	Controles	Actie
Een storing wordt op de afstandsbediening weergegeven		- Raadpleeg onderstaande storingentabel	
De ventilator start niet	Het scherm van de afstandsbediening (afhankelijk van de uitvoering) is aan	- Controleer de bedrading. - Controleer de motor: sluit de motor direct aan op een voeding van 230 V~ en zet de motor aan	Vervang het defecte onderdeel: de elektronische printkaart of de motor
	Het scherm van de afstandsbediening (afhankelijk van de uitvoering) is uit	- Controleer de bedrading. - Controleer de zekering op de elektronische printkaart.	Vervang het defecte onderdeel: de afstandsbediening of de elektronische printkaart.
	Versie zonder afstandsbediening	- Controleer de hele bedrading - Controleer de condensator (afhankelijk van de uitvoering). - Controleer de zekering van de toerenregelaar. - Controleer de uitgangsspanning van de toerenregelaar (afhankelijk van de uitvoering) - Controleer de motor: sluit de motor direct aan op een voeding van 230 V~. Bovendien: bij een EC-motor (EasyVEC® Compact 2000): zet de motor aan	Vervang het defecte onderdeel: de zekering, de condensator, de toerenregelaar of de motor
De ventilator start en stopt daarna		- Controleer de hele bedrading.	
De ventilator werkt niet volgens de ingestelde richtwaarde	Te laag toerental	- Controleer of de rotor soms aanloopt. - Controleer de condensator (afhankelijk van de uitvoering). - Stel de toerenregelaar in (afhankelijk van de uitvoering). - Controleer de uitgangsspanning van de toerenregelaar of de elektronische printkaart (afhankelijk van de uitvoering). - Controleer de goede werking van de druksensor(s) (afhankelijk van de uitvoering) door een geringe overdruk of onderdruk te veroorzaken in de drukmetingsbuizen. - Controleer de motor: sluit deze direct aan op een voeding van 230 V~. Bovendien: bij een EC-motor (EasyVEC® Compact 2000 en micro-watt en micro-watt + versies): zet de motor aan (neem contact op met onze Technische Dienst)	Vervang het defecte onderdeel: de condensator, de extra druksensor (micro-watt + versie), de toerenregelaar, de elektronische printkaart of de motor
	Te hoog toerental:	- Controleer de inschakelthermostaat van de brandbeveiliging en de bedrading ervan (afhankelijk van de uitvoering) - Controleer de goede staat, de stand en de elektrische aansluiting van de drukmetingsbuizen (afhankelijk van de uitvoering), ontstop deze buizen. - Controleer bovenstaande punten (als bij te laag toerental)	Vervang het defecte onderdeel: de inschakelthermostaat (van de brandbeveiliging). Zie hierboven (als bij te laag toerental)
	Het toerental verandert niet afhankelijk van de richtwaarde	- Controleer het luchtkanaalnetwerk op lekken. - Controleer bovenstaande punten (net als bij te laag of te hoog toerental)	Zie hierboven (te laag, te hoog toerental)
De ventilator draait de verkeerde kant op		- Controleer de bedrading in de aansluitkast van de motor (EasyVEC® 1000-2500)	
De werkstanden micro-watt + en constant luchtdebiet zijn niet meer beschikbaar (micro-watt + versie)		- Controleer de bedrading van de extra druksensor (micro-watt + versie)	Vervang de extra druksensor (micro-watt + versie)

N°	Betekenis	Diagnose / Oplossingen
E.50	Terugmelding: motortoerental = 0 tpm	Motor niet (goed) aangesloten of rotor geblokkeerd of motor defect
E.51	Terugmelding: motortoerental < 100 tpm	De rotor loopt aan of de motor is defect
E.52	De ventilator kan de minimumdrukrempeel niet bereiken	Controleer het hele systeem (op lekkage en drukverliezen in het kanaalsysteem) Controleer de goede staat en de elektrische aansluiting van de drukmetingsbuizen, ontstop deze.
		Constante druk 80 Pa.
		Automatisch gereguleerde druk: 50 Pa
		Hyrogereguleerde druk: 80 Pa
		T.Flow gereguleerde druk: 110 Pa
Expert gereguleerde druk: 50 Pa		
	Constant debiet NA	
	Aansturing 0-10 V: NA	
E.53	Gemeten druk is incoherent (te hoog)	Druksensor defect
E.88	Gestuurde verbinding met de afstandsbediening	Afstandsbediening defect
E.251	Werkling in brandbeveiligde stand, elektrisch circuit van thermoschakelaar is onderbroken	Los contact in de bedrading van de thermoschakelaar of de thermoschakelaar zelf is defect

Al deze storingsnummers verdwijnen na het verhelpen van de storing of na een reset (zie 6.4).





Bij een probleem kunt u een algehele reset uitvoeren (Reset: zie 6.4). Raadpleeg onze Technische Dienst als het probleem blijft bestaan.

Síntoma 1	Síntoma 2	Verificaciones	Acción
Se visualiza un defecto en el telecomando		- Remitirse a la tabla de los códigos error a continuación	
El ventilador no arranca	La pantalla del telecomando (según versión) está encendida	- Controlar todos los cableados. - Controlar el motor: alimentarlo directamente con 230 V~. Aplicar un comando de marcha al motor	Reemplazar la pieza incriminada: tarjeta electrónica de comando o motor
	La pantalla del telecomando (según versión) está apagada	- Controlar todos los cableados. - Controlar el fusible en la tarjeta electrónica de mando.	Reemplazar la pieza incriminada: telecomando o tarjeta electrónica de comando.
	Versión sin telecomando	- Controlar todos los cableados - Controlar el condensador (según versión). - Controlar el fusible del variador de velocidad. - Controlar la tensión de salida del variador de velocidad (según versión) - Controlar el motor: alimentarlo directamente con 230 V~. Además, en el motor EC (EasyVEC® Compact 2000): aplicar un comando de marcha al motor	Reemplazar la pieza incriminada: fusible, condensador, variador de velocidad o motor
El motor arranca y después se para		- Controlar todos los cableados.	
El ventilador no funciona a la consigna regulada	Baja velocidad	- Verificar que la rueda no fricciona. - Controlar el condensador (según versión). - Regular el variador de velocidad (según versión). - Controlar la tensión de salida del variador de velocidad o de la tarjeta electrónica de comando (según versión). - Controlar la funcionalidad del o de los captadores de presión (según versión) simulando una ligera sobrepresión o depresión en los tubos de presión. - Controlar el motor: alimentarlo directamente con 230 V~. Además, en el motor EC (EasyVEC® Compact 2000 y versiones microvatio y microvatio +): aplicar un comando de marcha al motor (contactar con la asistencia técnica)."	Reemplazar la pieza incriminada: condensador, captador de presión adicional (versión microvatio +), variador de velocidad, tarjeta electrónica de comando o motor.
	Alta velocidad	- Controlar el termocontacto de desconexión del modo incendio y su cableado (según versión) - Controlar el estado, la posición y la buena conexión de los tubos de presión (según versión), destaponarlos. - Controlar los puntos anteriores (baja velocidad)	Reemplazar la pieza incriminada: termocontacto (de desconexión modo incendio). Ver anteriormente (baja velocidad)
	La velocidad no varía en una variación de consigna	- Controlar la red aerúlica en búsqueda de fuga. - Controlar los puntos anteriores (alta velocidad, baja velocidad)	Ver anteriormente (alta velocidad, baja velocidad)
El ventilador gira en sentido inverso		- Controlar el cableado en la caja de bornes del motor (EasyVEC® de 1000 a 2500)	
Los modos microvatio + y caudal constante ya no están disponibles (versión microvatio +)		- Controlar el cableado del captador de presión adicional (versión microvatio +)	Cambiar el captador de presión adicional (versión microvatio +)

Nº	Significado	Diagnóstico / Soluciones
E.50	Retorno de velocidad motor = 0 rpm	Motor desconectado o rotor bloqueado o motor fuera de servicio
E.51	Retorno de velocidad motor = < 100 rpm	La rueda fricciona o el motor está fuera de servicio
E.52	El ventilador no alcanza el límite de presión mínimo	Controlar el sistema completo (fugas y pérdidas de carga red) Controlar el estado y la buena conexión de los capilares, destaponarlos.
		Presión constante: 80 Pa.
		Presión regulada autorregulable: 50 Pa
		Presión regulada higrorregulable: 80 Pa
		Presión regulada T. Flow: 110 Pa
	Caudal constante: NA	
	Pilotaje 0-10 V: NA	
E.53	Presión medida incoherente (demasiado alta)	Captador de presión fuera de servicio
E.88	Defecto de comunicación con el telecomando	Telecomando fuera de servicio
E.251	Funcionamiento en modo incendio, circuito del termocontacto abierto	El cableado del termocontacto o el propio termocontacto están fuera de servicio.

Todos estos números de error desaparecen después de solucionar la anomalía y de la puesta a cero (ver 6.4).  
En caso de problema, usted puede hacer una reinicialización total (reset: ver 6.4) y, si el problema persiste, consultar nuestro SPV.

Sintomo 1	Sintomo 2	Verifiche	Azione
Sul telecomando è visualizzato un guasto		- Riportarsi alla tabella dei codici errore in basso	
Il ventilatore non parte	Il display del telecomando (secondo la versione) è acceso	- Controllare tutti i cablaggi. - Controllare il motore: alimentarlo in diretta 230V~. Dare un comando di marcia al motore	Sostituire il pezzo difettoso: scheda elettronica di controllo o motore
	Il display del telecomando (secondo la versione) è spento	- Controllare tutti i cablaggi. - Controllare il fusibile sulla scheda elettronica di controllo.	Sostituire il pezzo difettoso: telecomando o scheda elettronica di controllo.
	Versione senza telecomando	- Controllare tutti i cablaggi. - Controllare il condensatore (secondo versione). - Controllare il fusibile del variatore di velocità. - Controllare la tensione di uscita del variatore di velocità (secondo versione) - Controllare il motore: alimentarlo in diretta 230V~. Inoltre, su motore EC (EasyVEC® Compact 2000): dare un comando di marcia al motore	Sostituire il pezzo difettoso: fusibile, condensatore, variatore di velocità o motore
Il ventilatore parte ma poi si ferma		- Controllare tutti i cablaggi.	
Il ventilatore non funziona al valore regolato	Velocità debole	- Verificare che la ruota non faccia attrito. - Controllare il condensatore (secondo versione). - Regolare il variatore di velocità (secondo versione). - Controllare la tensione di uscita del variatore di velocità (secondo versione) o della scheda elettronica di controllo (secondo versione). - Controllare la funzionalità del o dei sensori di pressione (secondo versione) simulando una leggera sovrappressione o depressione nei tubi di pressione. - Controllare il motore: alimentarlo in diretta 230V~. Inoltre su motore EC (EasyVEC® Compact 2000 e versioni micro-watt e micro-watt +): dare un comando di marcia al motore (contattare l'Assistenza Tecnica)	Sostituire il pezzo difettoso: condensatore, sensore di pressione aggiuntivo (versione micro-watt +), variatore di velocità, scheda elettronica di controllo o motore
	Velocità elevata	- Controllare il contatto termico di attivazione del modo incendio ed il relativo cablaggio (secondo versione) - Controllare lo stato, la posizione e la corretta connessione dei tubi di pressione (secondo versione), stasarli. - Controllare i punti sopra indicati (velocità debole)	Sostituire il pezzo difettoso: contatto termico (attivazione modo incendio). Vedere sopra (velocità debole)
	La velocità non varia al variare della regolazione.	- Controllare la rete aeraulica e cercare eventuali perdite. - Controllare i punti sopra indicati (velocità elevata o debole)	Vedere sopra (velocità elevata o debole)
Il ventilatore gira in senso inverso		- Controllare il cablaggio nella morsettiera del motore (EasyVEC® da 1000 a 2500)	
I modi micro-watt + e portata costante non sono più disponibili (versione micro-watt +)		- Controllare il cablaggio del sensore di pressione aggiuntivo (versione micro-watt +)	Sostituire il sensore di pressione aggiuntivo (versione micro-watt +)

N°	Significato	Diagnosi / Soluzioni
E.50	Ritorno di velocità motore = 0 rpm	Motore scollegato o rotore bloccato o motore fuori servizio
E.51	Ritorno di velocità motore < 100 rpm	La ruota fa attrito o il motore è fuori servizio
E.52	Il ventilatore non raggiunge la soglia minima di pressione	Controllare il sistema completo (perdite e perdite di carico rete) Controllare lo stato e la corretta connessione dei capillari, stasarli.
		Pressione costante: 80 Pa
		Pressione regolata autoregolabile: 50 Pa
		Pressione regolata igreregolabile: 80 Pa
		Pressione regolata T.Flow: 110 Pa
	Portata costante: NA	
	Gestione 0-10 V: NA	
E.53	Pressione misurata incoerente (troppo alta)	Sensore di pressione fuori servizio
E.88	Guasto di comunicazione con il telecomando	Telecomando fuori servizio
E.251	Funzionamento in modo incendio, circuito del contatto termico aperto	Il cablaggio del contatto termico o lo stesso contatto termico sono fuori servizio

Tutti i numeri di errore scompaiono con la risoluzione dell'anomalia e il reset (vedere 6.4).

In caso di problema si può reinizializzare completamente (reset: vedere 6.4); se il problema persiste, contattare il nostro SPV.



[www.aldes.com](http://www.aldes.com)