



## PRODUCT DESCRIPTION

The E280-SRG energy recovery ventilator provides high-efficiency energy recovery in a compact. The unit uses a robust, high-latent transfer membrane core that can withstand a wide range of environmental conditions. The E280-SRG can exchange up to 269 CFM at 0.20 in.w.g (ESP), making it ideal for large home applications.

### KEY FEATURES

Electronically and independently adjustable supply and exhaust blowers (FLEXControl)

Gauge ports on the door for fast and reliable airflow readings

Non-dust-loading backward-inclined impellers on totally enclosed motors

Twist-in collars for easy flex-duct attachment

Easy access to core and filters for cleaning

Durable High Latent Transfer enthalpy core has exceptional moisture transfer for increased comfort and no drain required.

Recirculating defrost protects the core from freezing without putting the dwelling into negative-pressure

# RESIDENTIAL

## ERV

### E280-SRG

ENERGY RECOVERY VENTILATOR  
269 CFM at 0.20 in.w.g (ESP)



UNIT

CORE



### Recovery Core

Material: High-latent-transfer (HLT)

### Casing

Material: Pre-painted 24-gauge galvanized steel

Duct Connections: Ø 6" (Ø 127 mm)

Insulation: 1" (25 mm) Fiberglass with FSK

Width: 31" (787 mm)

Height: 21-3/4" (552 mm)

Depth: 17-1/16" (433 mm)

Weight: 62 lbs (28 kg); Shipping Weight: 71 lbs (32 kg)

Supply Damper: Motorized

Exhaust Damper: Gravity



### Mounting

Suspended by chains with vibration-isolating springs



### Electrical requirement

120 VAC, 60 Hz, 2.89 A, 263 W

Cord Set: 48" (1219 mm) with ground



### Frost control

Recirculation cycles controlled by a temperature sensor when outdoor temperatures fall below 14°F (-10°C).



### Filters

Type : Two Aluminum (No. 300500266)

Option (sold separately) :

Two Carbon (No. 300500264),

Two High Efficiency/MERV13 Equivalent (No. 300500265)

Two MERV8 (No. 301607000)



### Blowers

Two backward-inclined motorized impeller, direct-drive PSC, variable speed, external rotor

# DIMENSIONS

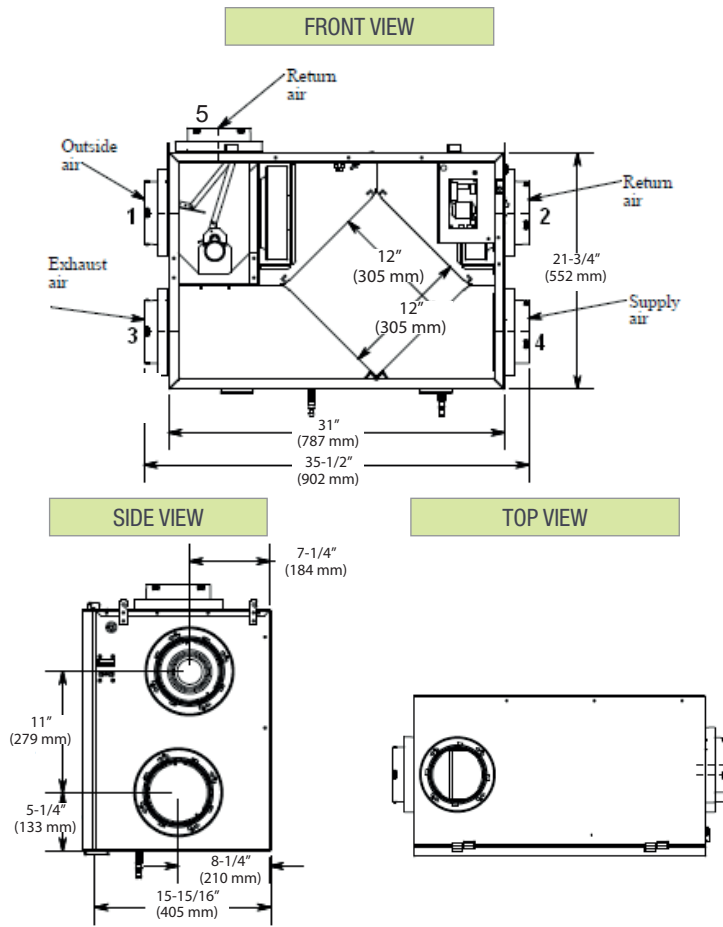

# CONTROLS

Low voltage dry contact (24VAC) for interlock with heating/cooling systems.



Digital Multifunction Control (No. 200500242\_FC)



LCD Electronic Multifunction Control (No. 200500227)



20/40/60 Minute Timer (No. 200500228)



Speed Control (Low/Intermittent/High) (No. 200500229)



Mode Control (Recirculation) (No. 200500230)

# PERFORMANCE

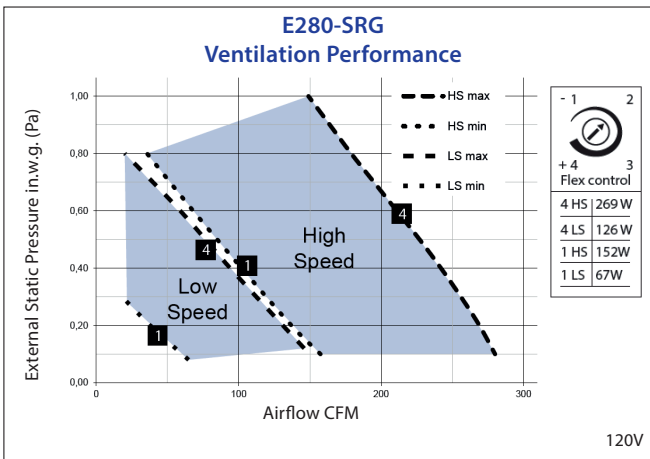

Supply Temperature		Net Airflow		Power Consumed (W)	Sensible Recovery Efficiency	Adjusted Sensible Recovery Efficiency	Latent Recovery
°F	°C	CFM	L/s				
<b>Heating</b>							
32	0	64	30	84	77%	86%	0.73
32	0	81	38	94	76%	84%	0.69
32	0	121	57	146	72%	80%	0.60
-13	-25	67	31	107	70%	75%	0.68
<b>Cooling</b>							
95	35	81	38	94	57%	62%	0.58

Project:		Architect:	
Location:		Engineer:	
Model #:		Contractor:	
Quantity:		Comments:	
Submitted By:			
Date:			

For more information, contact your Aldes sales advisor, visit [aldes-na.com](http://aldes-na.com), call 1.800.255.7749, or find us on

