



PLATE EXCHANGER

High-efficiency polymeric membrane counter-flow ERV

CASING (Standard)

Material: 24-gauge galvanized steel
Drain connections: optional
Duct connections: 5" (127 mm)
Insulation: EPS molded polystyrene
Length: 23" (584.2 mm)
Height: 19" (482.6 mm)
Width: 16" (406.4 mm)
Weight: 51 lb (23 kg)
Exhaust Damper: Closed by gravity
Swivel ports for horizontal, vertical, oblique or mixed installations.



MOUNTING

Mounting chains included
Wall mounting optional (No. 200400921)



ELECTRICAL SPECIFICATIONS

120 V, 60 Hz, 181 W, 2.06 A



FILTERS

(Standard)
Quantity:
2 washable MERV 6 filters (No. 200607771)
Optional filter types: MERV 8 (No. 200607772)
MERV 13 (No. 100607881)

InspirAIR® ELITE ERV

EK150-TF

155 CFM at 0.4 in.w.g



UNIT

CORE



BLOWERS & MOTORS

Two motorized impellers (backwards inclined)
Quick-connect motors for easy and efficient maintenance
PSC motor



DEFROST

Automatic timed integral exhaust defrost: cycles are controlled by a temperature sensor when the outdoor temperature drops below 10.4°F (-12°C)

WARRANTY

Limited 5 years on the cores and all covered components

WALL CONTROLS

Low voltage dry contact (24VAC) for interlock with heating and cooling systems. For more details, please refer to the wall control specification sheets.



Digital Multifunction Control (No. 200500242_FC)



LCD Electronic Multifunction Control
(No. 200500227)



20/40/60 Minute Timer (No. 200500228)



Speed Control (Low/Intermittent/High)
(No. 200500229)



Mode Control (Recirculation) (No. 200500230)

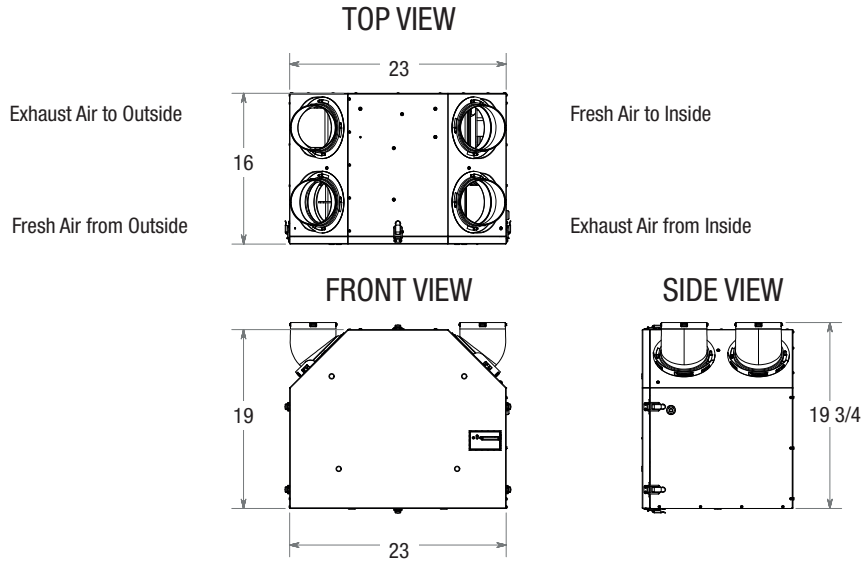

EK150-TF: PERFORMANCE

EK150-TF Ventilation Performance

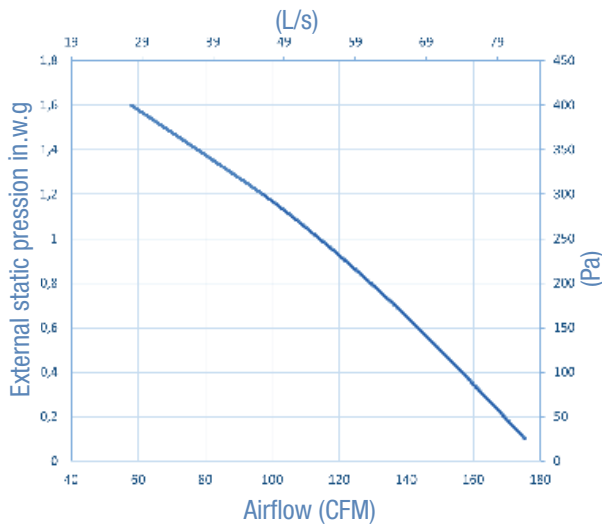

Thermal Performance – EK150-TF								
Supply Temperature		Net Airflow		Power Consumed (w)	Sensible Recovery Efficiency	Adjusted Sensible Recovery Efficiency	Latent Recovery/Moisture Transfer	Total Recovery Efficiency
°F	°C	CFM	L/s					
Heating								
32	0	36	17	59	87%	99%	96%	-
32	0	50	23	70	86%	96%	92%	-
32	0	64	30	81	85%	94%	90%	-
32	0	80	38	95	83%	91%	87%	-
-13	-25	82	39	88	62%	65%	62%	-
Cooling								
95	35	65	30	80	-	-	86%	76%

Project:		Architect:	
Location:		Engineer:	
Model #:		Contractor:	
Quantity:		Comments:	
Submitted By:			
Date:			

For more information, contact your Aldes sales advisor, visit aldes-na.com, call 1.800.255.7749, or find us on

