



Intertek
C22.2 no113
UL 1812



InspirAIR® ELITE

HRV

HK150-TQG

161 CFM at 0.4 in.w.g



UNIT

CORE



PLATE EXCHANGER

Polypropylene Counterflow HRV

CASING (Standard)

Material: 24-gauge galvanized steel

Drain connections: optional

Duct connections: 5" (127 mm)

Insulation: EPS molded polystyrene

Length: 23" (584.2 mm)

Height: 19" (482.6 mm)

Width: 16" (406.4 mm)

Weight: 46 lb (21 kg)

Exhaust Damper: Closed by gravity

Fresh air Damper: Motorized

Swivel ports for horizontal, vertical, oblique and mixed installations



MOUNTING

Mounting chains included

Wall mounting optional (No. 200400921)



ELECTRICAL SPECIFICATIONS

120 V, 60 Hz, 187 W, 2.51 A



FILTERS

(Standard)

Quantity:

2 washable MERV 6 filters (No. 70033)

Optional filter types: MERV 8 (No. 70034)

MERV 13 (No. 70035)



BLOWERS & MOTORS

Two motorized impellers (backwards inclined)

Quick-connect motors for easy and efficient maintenance
PSC motor



DEFROST

Automatic Programmed Recirculation: Cycles are controlled by a temperature sensor when the outside temperature drops below -5°C (23°F)

WARRANTY

Limited 5 years on the cores and all covered components

WALL CONTROLS

Low voltage dry contact (24VAC) for interlock with heating and cooling systems. For more details, please refer to the wall control specification sheets.



Digital Multifunction Control (No. 200500242_FC)



LCD Electronic Multifunction Control
(No. 200500227)



20/40/60 Minute Timer (No. 200500228)



Speed Control (Low/Intermittent/High)
(No. 200500229)



Mode Control (Recirculation) (No. 200500230)

aldes DIMENSIONS (INCHES)

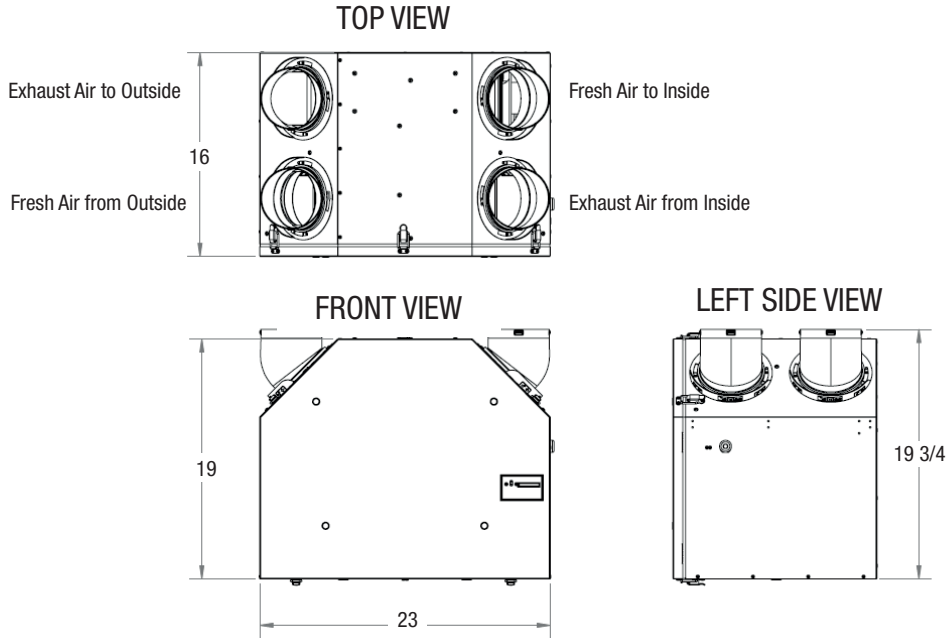

HK150-TQG: PERFORMANCE

HK150-TQG Ventilation Performance

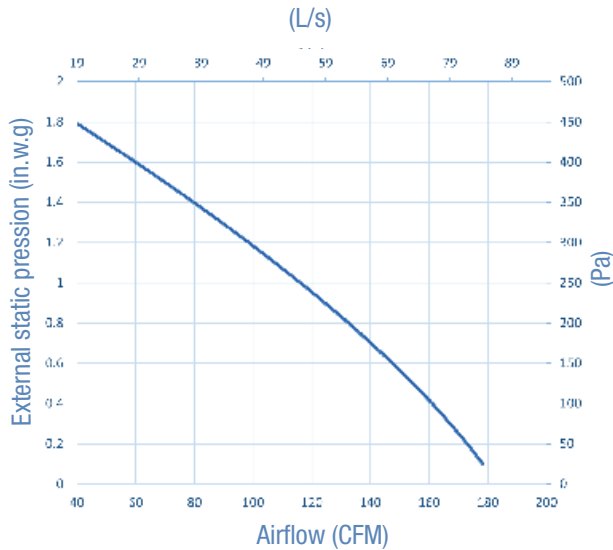

Thermal Performance – HK150-TQG								
Supply Temperature		Net Airflow		Power Consumed (w)	Sensible Recovery Efficiency	Adjusted Sensible Recovery Efficiency	Latent Recovery/Moisture Transfer	Total Recovery Efficiency
°F	°C	CFM	L/s					
Heating								
32	0	36	17	64	83%	96%	4%	-
32	0	51	24	77	83%	94%	3%	-
32	0	66	31	88	82%	92%	2%	-
32	0	81	38	97	81%	90%	7%	-
-13	-25	83	39	148	61%	66%	8%	-

Project:		Architect:	
Location:		Engineer:	
Model #:		Contractor:	
Quantity:		Comments:	
Submitted By:			
Date:			

For more information, contact your Aldes sales advisor, visit aldes-na.com, call 1.800.255.7749, or find us on

